

Property Class: 510
Neighborhood 002304-TS70
Map:
Block:
Card:
Bk: Pg:

GRANVILLE TWP-ST HENRY CORP / ST HENRY SD
11-16-276-016

23-075800.0107

ALEXANDER JOHN J & MARA L
ALEXANDER JOHN J & MARA L
531 E COLUMBUS ST
SAINT HENRY, OH 45883
Created in 2015 From 23-075800.0000 due to New

LEGAL INFORMATION
NORTHERN HEIGHTS SUBDIVISION

LOT:# 6 & 7

OWNERSHIP	ADDRESS	CITY	STATE	ZIP	DATE	AMOUNT	DEED:CONV#	JS	VALID
1 ALEXANDER JOHN J & MARA L	531 E COLUMBUS ST	SAINT HENRY	OH	45883	06/19/2020	108,000	2:WDC : 376	<input type="checkbox"/>	<input checked="" type="checkbox"/>
2 LANGE DEVELOPMENTS LLC	821 COOPER DR	SAINT HENRY	OH	45883	09/28/2015	0	WDC : 0	<input type="checkbox"/>	<input type="checkbox"/>
3						0	0	<input type="checkbox"/>	<input type="checkbox"/>

X: TTO LISTER: TK DATE: 07/11/2023 TIME: 12:00:00 AM LETTER LETTER REC'D GIS CODE

STREET/ROAD	TOPOGRAPHY	PU-UTILITIES-PR	NEIGHBORHOOD	INFLUENCE FACTORS	PROPERTY LOCATION	
<input type="checkbox"/> PAVED <input type="checkbox"/> GRAVEL <input type="checkbox"/> DIRT <input type="checkbox"/> SIDEWALKS <input type="checkbox"/> CURBS	<input type="checkbox"/> LEVEL <input type="checkbox"/> HIGH <input type="checkbox"/> LOW <input type="checkbox"/> ROLLING <input type="checkbox"/> STANDARD	<input type="checkbox"/> WATER <input type="checkbox"/> SEWER <input type="checkbox"/> GAS <input type="checkbox"/> ELECTRIC <input type="checkbox"/> STANDARD	<input type="checkbox"/> IMPROVING <input type="checkbox"/> STATIC <input type="checkbox"/> DECLINING <input type="checkbox"/> OLD <input type="checkbox"/> STANDARD	<input type="checkbox"/> A. NO ROAD <input type="checkbox"/> B. TOPGRHY <input type="checkbox"/> C. Ex Front <input type="checkbox"/> D. QUANTITY <input type="checkbox"/> E. SZ/SHAPE	<input type="checkbox"/> F. RESTRICT <input type="checkbox"/> G. WOOD LT <input type="checkbox"/> H. VACANCY <input type="checkbox"/> I. WATER FRONT <input type="checkbox"/> J. OTHER/CDU	451 ACCESS DR, ST HENRY COMMENT TY2022:Net Gen=\$7,145.22, Other Assessment=\$0.00 DE20 RMV DEV DISCOUNT DE22 ADD LOTS 6 & 7 TOGETHER (DWLG SITS ON BOTH) DE22 ADD DWGL @ 80% COMPL DE23 TTO; DWLG COMPL

LAND COMPUTATIONS							
LAND TYPE	SIZE	M	RATE	C	INF	M VALUE	C
F:Front	F280 D140	ST455	DP96	ADJ437		122,400	0
TOTAL						122,400	0

VALUATION SUMMARY							
VALUE YEAR	2023	2022	2022	2020	2020	2017	
REASON FOR CHANGE	NC	RCLS	NC	RAPP	MISC	RAPP	
APPRAISED LAND	122,400	74,200	74,200	27,800	23,200	16,200	
VALUE IMPR	847,800	459,100	459,100	0	0	0	
TOTAL	970,200	533,300	533,300	27,800	23,200	16,200	
ASSESSED LAND	42,840	25,970	25,970	9,730	8,120	5,670	
VALUE IMPR	296,730	160,690	160,690	0	0	0	
TOTAL	339,570	186,660	186,660	9,730	8,120	5,670	

OCCUPANCY		EXTERIOR	
<input checked="" type="checkbox"/> SF	<input type="checkbox"/> DU	<input type="checkbox"/> WOOD	<input type="checkbox"/> TR
<input type="checkbox"/> CONVERSION	<input type="checkbox"/> BUILDING TYPE	<input type="checkbox"/> STUCCO	<input checked="" type="checkbox"/> ALM/VYNL
<input type="checkbox"/> MOBILE HOME	<input type="checkbox"/> BI/TR LEVEL	<input type="checkbox"/> CONC BLK	<input type="checkbox"/> METAL
<input type="checkbox"/> MOD/MAN	<input type="checkbox"/>	<input type="checkbox"/> BRICK	<input checked="" type="checkbox"/> STONE

ROOFING		ROOF TYPE	
<input type="checkbox"/> METAL	<input type="checkbox"/> SLT/TLE	<input type="checkbox"/> GABLE	<input checked="" type="checkbox"/> HIP
<input checked="" type="checkbox"/> SHINGLES	<input type="checkbox"/> SHAKES	<input type="checkbox"/> GAMBREL	<input type="checkbox"/> MANSARD
<input type="checkbox"/> COMPOSITE	<input type="checkbox"/>	<input type="checkbox"/> FLAT	<input type="checkbox"/>

FLOORS		B	1	2	3	U
CONCRETE	<input type="checkbox"/>	<input type="checkbox"/>	<input type="checkbox"/>	<input type="checkbox"/>	<input type="checkbox"/>	<input type="checkbox"/>
WOOD	<input type="checkbox"/>	<input type="checkbox"/>	<input type="checkbox"/>	<input type="checkbox"/>	<input type="checkbox"/>	<input type="checkbox"/>
TILE/COMPO	<input type="checkbox"/>	<input checked="" type="checkbox"/>	<input type="checkbox"/>	<input checked="" type="checkbox"/>	<input type="checkbox"/>	<input type="checkbox"/>
CARPET	<input type="checkbox"/>	<input type="checkbox"/>	<input type="checkbox"/>	<input type="checkbox"/>	<input type="checkbox"/>	<input type="checkbox"/>

INT. FINISH		B	1	2	3	U
PLASTER/DW	<input type="checkbox"/>	<input checked="" type="checkbox"/>	<input type="checkbox"/>	<input checked="" type="checkbox"/>	<input type="checkbox"/>	<input type="checkbox"/>
PANELING	<input type="checkbox"/>	<input type="checkbox"/>	<input type="checkbox"/>	<input type="checkbox"/>	<input type="checkbox"/>	<input type="checkbox"/>
UNFINISHED	<input checked="" type="checkbox"/>	<input type="checkbox"/>	<input type="checkbox"/>	<input type="checkbox"/>	<input type="checkbox"/>	<input type="checkbox"/>

ACCOMMODATIONS		B	1	2	3	U
# OF ROOMS		4			3	
BEDROOMS		1			3	
FIREPLACES		1				

HEAT & AC		B	1	2	3	U
NO HEAT	<input type="checkbox"/>	<input type="checkbox"/>	<input type="checkbox"/>	<input type="checkbox"/>	<input type="checkbox"/>	<input type="checkbox"/>
CTRL HEAT	<input type="checkbox"/>	<input checked="" type="checkbox"/>	<input checked="" type="checkbox"/>	<input checked="" type="checkbox"/>	<input type="checkbox"/>	<input type="checkbox"/>
HW/STEAM	<input type="checkbox"/>	<input type="checkbox"/>	<input type="checkbox"/>	<input type="checkbox"/>	<input type="checkbox"/>	<input type="checkbox"/>
ELECTRIC	<input type="checkbox"/>	<input type="checkbox"/>	<input type="checkbox"/>	<input type="checkbox"/>	<input type="checkbox"/>	<input type="checkbox"/>
HEAT PUMP	<input type="checkbox"/>	<input type="checkbox"/>	<input type="checkbox"/>	<input type="checkbox"/>	<input type="checkbox"/>	<input type="checkbox"/>
FLR/WALL	<input type="checkbox"/>	<input type="checkbox"/>	<input type="checkbox"/>	<input type="checkbox"/>	<input type="checkbox"/>	<input type="checkbox"/>
STVE/SPCE	<input type="checkbox"/>	<input type="checkbox"/>	<input type="checkbox"/>	<input type="checkbox"/>	<input type="checkbox"/>	<input type="checkbox"/>
GEOHERMAL	<input type="checkbox"/>	<input type="checkbox"/>	<input type="checkbox"/>	<input type="checkbox"/>	<input type="checkbox"/>	<input type="checkbox"/>
OUTSIDE	<input type="checkbox"/>	<input type="checkbox"/>	<input type="checkbox"/>	<input type="checkbox"/>	<input type="checkbox"/>	<input type="checkbox"/>
CTRL A/C	<input type="checkbox"/>	<input checked="" type="checkbox"/>	<input checked="" type="checkbox"/>	<input checked="" type="checkbox"/>	<input type="checkbox"/>	<input type="checkbox"/>

PLUMBING		BASE	
X FULL BATH			1
X HALF BATH	1		
X FIXTURES	2		

FLOOR	AREA	CONST	VALUE
1	2661	FR	284,270
.25	224	FR	21,830
2ND	1212	FR	62,150
BSMT	2661		38,050
SUBTOTAL			406,300
MULTI-FAMILY #	0		0
BUILDING TYPE	100%		0
BSMT FINISH	0 S.F.		0
FIREPLACE #	1		4,400
HEATING	0 S.F.		0
AIR COND	4,097 S.F.		6,760
PLUMBING #	7		8,470
GARAGES & CARPORTS			38,100
EXTRA FEATURES			29,400
SUBTOTAL			493,430
GRADE FACTOR			150 %
UNADJUSTED VALUE			740,150
FACTOR			100 %

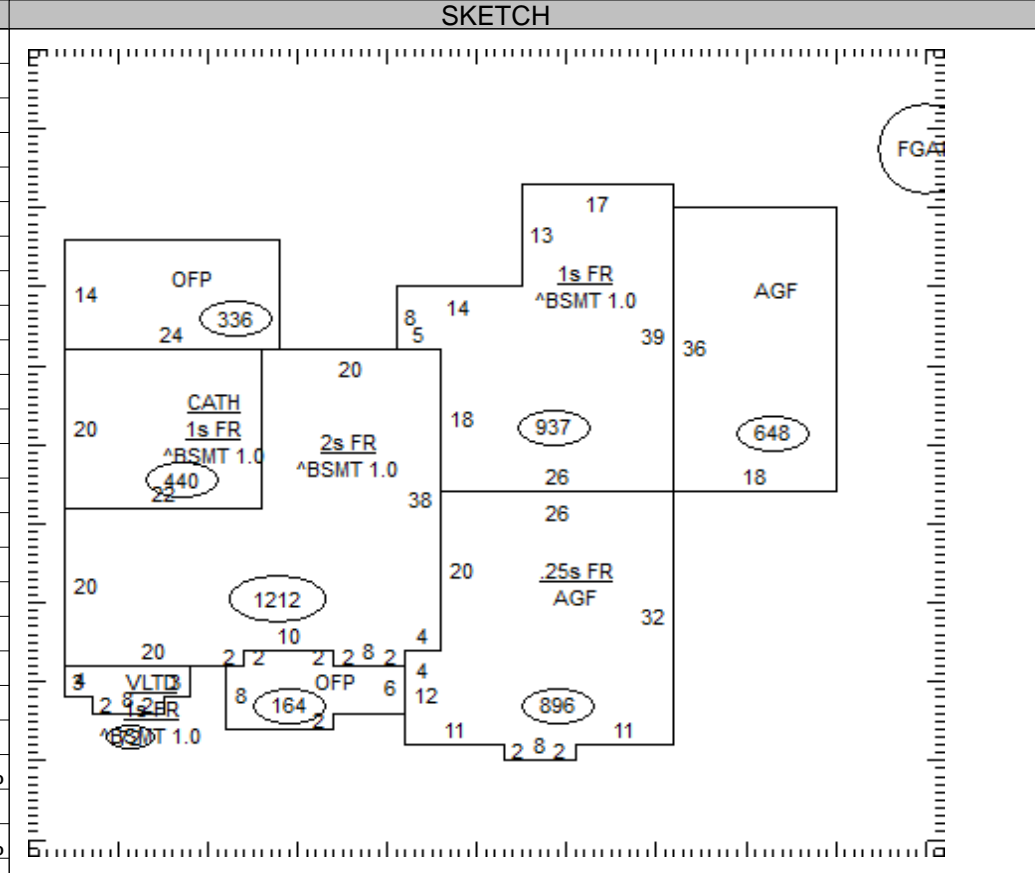

OCCUPANCY	ST.HT	SIZE	AREA	GRADE	PRICE	AGE	REMD	CND	UNADJ VAL	PHYS	PHYS VAL	FUNC	TRUE VAL
DWELLING	2	SK	4,097	A-		2021		G	740,150	1	732,750		806,000
1 Gar - Frame		30x50	1,500	B	28.44	2021		A	42,660	2	41,810		41,800
2													
3													
4													
5													
6													
7													
8													
9													
10													
11													

23-075800.0107

TOTAL 847,800

COMMENTS

Dwelling has an Economic Factor of 110%