

GRANVILLE TWP-ST HENRY CORP / ST HENRY SD  
11-21-427-006

Property Class: 510

Neighborhood  
002308

Map:

Block:

Card:

Bk: Pg:

23-075400.4600

**LEICHTY KEENAN R II & TRICIA K**  
LEICHTY KEENAN R II & TRICIA K  
502 HICKORY ST  
SAINT HENRY, OH 45883  
From 23-075400.0000 due to Split

**LEGAL INFORMATION**  
SOUTHVIEW ESTATES  
FOURTH ADDITION  
LOT #44

	OWNERSHIP	ADDRESS	CITY	STATE	ZIP	DATE	AMOUNT	DEED:CONV#	JS	VALID
1	LEICHTY KEENAN R II & TRICIA	502 HICKORY ST	SAINT HENRY	OH	45883	06/16/2021	361,000	WDC : 476	<input type="checkbox"/>	<input checked="" type="checkbox"/>
2	UHLENHAKE TAYLOR R	502 HICKORY ST	SAINT HENRY	OH	45883	01/30/2015	280,000	WDC : 49	<input type="checkbox"/>	<input checked="" type="checkbox"/>
3	LAGUIRE SCOTT A & AMBER L	502 HICKORY ST	SAINT HENRY	OH	45883	08/04/2006	225,200	WDC : A : 632	<input type="checkbox"/>	<input type="checkbox"/>

X:  TTO LISTER: DATE: 08/04/2020 TIME: 12:00:00 AM  LETTER  LETTER REC'D GIS CODE

STREET/ROAD TOPOGRAPHY PU-UTILITIES-PR NEIGHBORHOOD INFLUENCE FACTORS PROPERTY LOCATION

PAVED  LEVEL  WATER  IMPROVING  A. NO ROAD  F. RESTRICT 502 HICKORY ST  
 GRAVEL  HIGH  SEWER  STATIC  B. TOPGRHY  G. WOOD LT COMMENT  
 DIRT  LOW  GAS  DECLINING  C. Ex Front  H. VACANCY TY2022:Net Gen=\$4,245.94, Other  
 SIDEWALKS  ROLLING  ELECTRIC  OLD  D. QUANTITY  I. WATER FRONT Assessment=\$0.00  
 CURBS  STANDARD  STANDARD  E. SZ/SHAPE  J. OTHER/CDU DE20 PER SOCIAL MEDIA; UPDATE BSMNT  
 FINISH  
 DE09 PER DATA MAILER CORRECTED PLMG  
 DE16 DESK TOP REVIEW//CORR FR TO BRK  
 DE22 RMV OWN OCC - DID NOT RETURN APP

LAND COMPUTATIONS

LAND TYPE	SIZE	M	RATE	C	INF	M	VALUE	C
F:Front	F110 D140	ST510	DP96	ADJ490			53,900	0
TOTAL							53,900	0

VALUATION SUMMARY

VALUE YEAR	2023	2020	2020	2017				
REASON FOR CHANGE	RAPP	RAPP	NC	RAPP				
APPRaised	LAND	53,900	32,200	27,000	27,000			
VALUE	IMPR	355,000	284,700	280,400	252,900			
	TOTAL	408,900	316,900	307,400	279,900			
ASSESSED	LAND	18,870	11,270	9,450	9,450			
	IMPR	124,250	99,650	98,140	88,520			
	TOTAL	143,120	110,920	107,590	97,970			

<b>OCCUPANCY</b>		<b>EXTERIOR</b>	
<input checked="" type="checkbox"/> SF	<input type="checkbox"/> DU	<input type="checkbox"/> TR	<input type="checkbox"/> WOOD
<input type="checkbox"/> CONVERSION	<input type="checkbox"/> STUCCO		
<b>BUILDING TYPE</b>		<input type="checkbox"/> ALM/VYNL	
<input type="checkbox"/> MOBILE HOME	<input type="checkbox"/> CONC BLK		
<input type="checkbox"/> BI/TR LEVEL	<input type="checkbox"/> METAL		
<input type="checkbox"/> MOD/MAN	<input checked="" type="checkbox"/> BRICK		
<input type="checkbox"/>	<input type="checkbox"/> STONE		

<b>ROOFING</b>		<b>ROOF TYPE</b>	
<input type="checkbox"/> METAL	<input type="checkbox"/> GABLE		
<input type="checkbox"/> SLT/TLE	<input checked="" type="checkbox"/> HIP		
<input checked="" type="checkbox"/> SHINGLES	<input type="checkbox"/> GAMBREL		
<input type="checkbox"/> SHAKES	<input type="checkbox"/> MANSARD		
<input type="checkbox"/> COMPOSITE	<input type="checkbox"/> FLAT		

<b>FLOORS</b>		B	1	2	3	U
CONCRETE	<input checked="" type="checkbox"/>	<input type="checkbox"/>	<input type="checkbox"/>	<input type="checkbox"/>	<input type="checkbox"/>	<input type="checkbox"/>
WOOD	<input type="checkbox"/>	<input type="checkbox"/>	<input type="checkbox"/>	<input type="checkbox"/>	<input type="checkbox"/>	<input type="checkbox"/>
TILE/COMPO	<input checked="" type="checkbox"/>	<input checked="" type="checkbox"/>	<input type="checkbox"/>	<input type="checkbox"/>	<input type="checkbox"/>	<input type="checkbox"/>
CARPET	<input checked="" type="checkbox"/>	<input checked="" type="checkbox"/>	<input type="checkbox"/>	<input type="checkbox"/>	<input type="checkbox"/>	<input type="checkbox"/>
<b>INT. FINISH</b>		B	1	2	3	U
PLASTER/DW	<input checked="" type="checkbox"/>	<input checked="" type="checkbox"/>	<input type="checkbox"/>	<input type="checkbox"/>	<input type="checkbox"/>	<input type="checkbox"/>
PANELING	<input type="checkbox"/>	<input type="checkbox"/>	<input type="checkbox"/>	<input type="checkbox"/>	<input type="checkbox"/>	<input type="checkbox"/>
UNFINISHED	<input checked="" type="checkbox"/>	<input type="checkbox"/>	<input type="checkbox"/>	<input type="checkbox"/>	<input type="checkbox"/>	<input type="checkbox"/>

<b>ACCOMMODATIONS</b>						
# OF ROOMS		5				
BEDROOMS		3				
FIREPLACES						

<b>HEAT &amp; AC</b>		B	1	2	3	U
NO HEAT	<input type="checkbox"/>	<input type="checkbox"/>	<input type="checkbox"/>	<input type="checkbox"/>	<input type="checkbox"/>	<input type="checkbox"/>
CTRL HEAT	<input type="checkbox"/>	<input checked="" type="checkbox"/>	<input type="checkbox"/>	<input type="checkbox"/>	<input type="checkbox"/>	<input type="checkbox"/>
HW/STEAM	<input type="checkbox"/>	<input type="checkbox"/>	<input type="checkbox"/>	<input type="checkbox"/>	<input type="checkbox"/>	<input type="checkbox"/>
ELECTRIC	<input type="checkbox"/>	<input type="checkbox"/>	<input type="checkbox"/>	<input type="checkbox"/>	<input type="checkbox"/>	<input type="checkbox"/>
HEAT PUMP	<input type="checkbox"/>	<input type="checkbox"/>	<input type="checkbox"/>	<input type="checkbox"/>	<input type="checkbox"/>	<input type="checkbox"/>
FLR/WALL	<input type="checkbox"/>	<input type="checkbox"/>	<input type="checkbox"/>	<input type="checkbox"/>	<input type="checkbox"/>	<input type="checkbox"/>
STVE/SPCE	<input type="checkbox"/>	<input type="checkbox"/>	<input type="checkbox"/>	<input type="checkbox"/>	<input type="checkbox"/>	<input type="checkbox"/>
GEO THERMAL	<input type="checkbox"/>	<input type="checkbox"/>	<input type="checkbox"/>	<input type="checkbox"/>	<input type="checkbox"/>	<input type="checkbox"/>
OUTSIDE	<input type="checkbox"/>	<input type="checkbox"/>	<input type="checkbox"/>	<input type="checkbox"/>	<input type="checkbox"/>	<input type="checkbox"/>
CTRL A/C	<input type="checkbox"/>	<input checked="" type="checkbox"/>	<input type="checkbox"/>	<input type="checkbox"/>	<input type="checkbox"/>	<input type="checkbox"/>

<b>PLUMBING</b>		<b>BASE</b> <input checked="" type="checkbox"/>				
X FULL BATH		1				
X HALF BATH		1				
X FIXTURES	2					

FLOOR	AREA	CONST	VALUE
1	1966	BRK	248,400
BSMT	1966		28,110
<b>SUBTOTAL</b>			276,510
MULTI-FAMILY #	0		0
BUILDING TYPE	100%		0
BSMT FINISH	1,474 S.F.		21,080
FIREPLACE #	0		0
HEATING	0 S.F.		0
AIR COND	1,966 S.F.		3,240
PLUMBING #	7		8,470
GARAGES & CARPORTS			17,400
EXTRA FEATURES			3,500
<b>SUBTOTAL</b>			330,200
GRADE FACTOR			115 %
<b>UNADJUSTED VALUE</b>			379,730
FACTOR			100 %

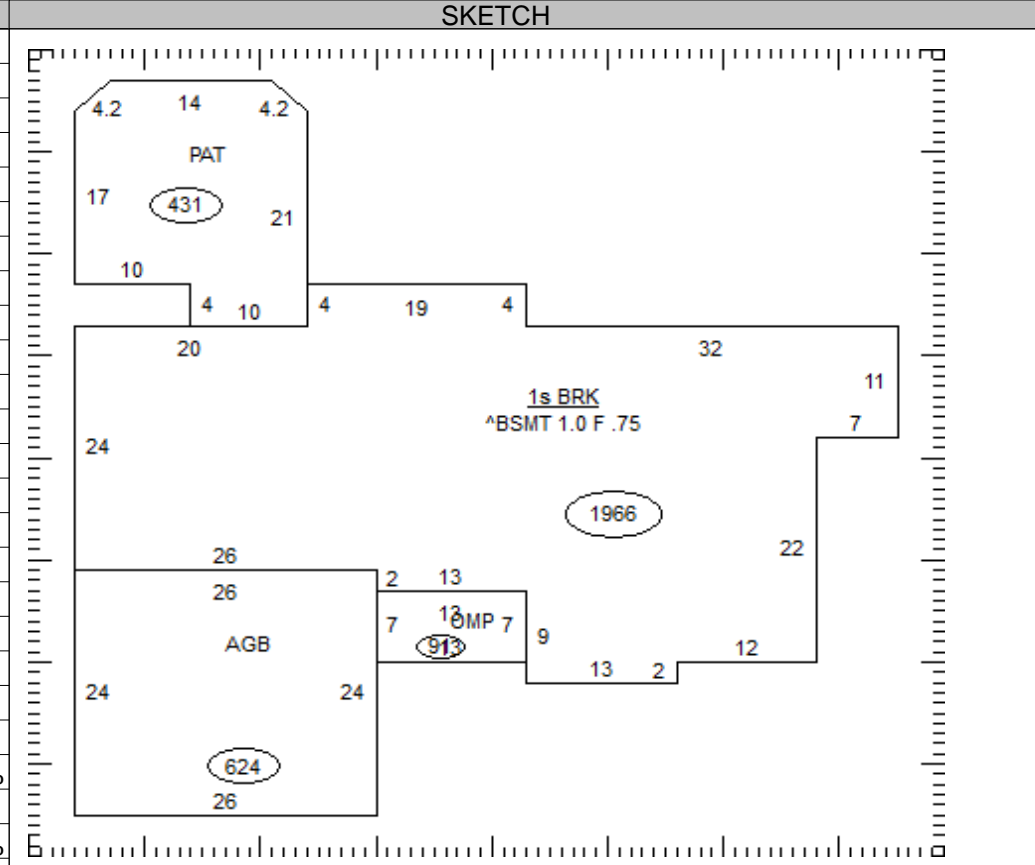

OCCUPANCY	ST.HT	SIZE	AREA	GRADE	PRICE	AGE	REMD	CND	UNADJ VAL	PHYS	PHYS VAL	FUNC	TRUE VAL
DWELLING	1	SK	1,966	B-		2006		A	379,730	15	322,770		355,000
1													
2													
3													
4													
5													
6													
7													
8													
9													
10													
11													

23-075400.4600

TOTAL 355,000

**COMMENTS**

TT BUILDER  
Dwelling has an Economic Factor of 110%



