

OCCUPANCY		EXTERIOR	
<input checked="" type="checkbox"/> SF	<input type="checkbox"/> DU	<input type="checkbox"/> TR	<input type="checkbox"/> WOOD
<input type="checkbox"/> CONVERSION		<input type="checkbox"/> STUCCO	
BUILDING TYPE		<input checked="" type="checkbox"/> ALM/VYNL	
<input type="checkbox"/> MOBILE HOME	<input type="checkbox"/> CONC BLK		<input type="checkbox"/> METAL
<input type="checkbox"/> BI/TR LEVEL	<input type="checkbox"/> BRICK		<input checked="" type="checkbox"/> STONE
<input type="checkbox"/> MOD/MAN			
<input type="checkbox"/>			

ROOFING		ROOF TYPE	
<input type="checkbox"/> METAL	<input type="checkbox"/> GABLE		<input type="checkbox"/>
<input type="checkbox"/> SLT/TLE	<input checked="" type="checkbox"/> HIP		<input type="checkbox"/>
<input checked="" type="checkbox"/> SHINGLES	<input type="checkbox"/> GAMBREL		<input type="checkbox"/>
<input type="checkbox"/> SHAKES	<input type="checkbox"/> MANSARD		<input type="checkbox"/>
<input type="checkbox"/> COMPOSITE	<input type="checkbox"/> FLAT		<input type="checkbox"/>

FLOORS		B	1	2	3	U
CONCRETE	<input type="checkbox"/>	<input type="checkbox"/>	<input type="checkbox"/>	<input type="checkbox"/>	<input type="checkbox"/>	<input type="checkbox"/>
WOOD	<input type="checkbox"/>	<input type="checkbox"/>	<input type="checkbox"/>	<input type="checkbox"/>	<input type="checkbox"/>	<input type="checkbox"/>
TILE/COMPO	<input type="checkbox"/>	<input checked="" type="checkbox"/>	<input type="checkbox"/>	<input type="checkbox"/>	<input type="checkbox"/>	<input type="checkbox"/>
CARPET	<input type="checkbox"/>	<input checked="" type="checkbox"/>	<input type="checkbox"/>	<input type="checkbox"/>	<input type="checkbox"/>	<input type="checkbox"/>

INT. FINISH		B	1	2	3	U
PLASTER/DW	<input type="checkbox"/>	<input checked="" type="checkbox"/>	<input type="checkbox"/>	<input type="checkbox"/>	<input type="checkbox"/>	<input type="checkbox"/>
PANELING	<input type="checkbox"/>	<input type="checkbox"/>	<input type="checkbox"/>	<input type="checkbox"/>	<input type="checkbox"/>	<input type="checkbox"/>
UNFINISHED	<input type="checkbox"/>	<input type="checkbox"/>	<input type="checkbox"/>	<input type="checkbox"/>	<input type="checkbox"/>	<input type="checkbox"/>

ACCOMMODATIONS						
# OF ROOMS		7				
BEDROOMS		3				
FIREPLACES						

HEAT & AC		B	1	2	3	U
NO HEAT	<input type="checkbox"/>	<input type="checkbox"/>	<input type="checkbox"/>	<input type="checkbox"/>	<input type="checkbox"/>	<input type="checkbox"/>
CTRL HEAT	<input type="checkbox"/>	<input checked="" type="checkbox"/>	<input type="checkbox"/>	<input type="checkbox"/>	<input type="checkbox"/>	<input type="checkbox"/>
HW/STEAM	<input type="checkbox"/>	<input type="checkbox"/>	<input type="checkbox"/>	<input type="checkbox"/>	<input type="checkbox"/>	<input type="checkbox"/>
ELECTRIC	<input type="checkbox"/>	<input type="checkbox"/>	<input type="checkbox"/>	<input type="checkbox"/>	<input type="checkbox"/>	<input type="checkbox"/>
HEAT PUMP	<input type="checkbox"/>	<input checked="" type="checkbox"/>	<input type="checkbox"/>	<input type="checkbox"/>	<input type="checkbox"/>	<input type="checkbox"/>
FLR/WALL	<input type="checkbox"/>	<input type="checkbox"/>	<input type="checkbox"/>	<input type="checkbox"/>	<input type="checkbox"/>	<input type="checkbox"/>
STVE/SPCE	<input type="checkbox"/>	<input type="checkbox"/>	<input type="checkbox"/>	<input type="checkbox"/>	<input type="checkbox"/>	<input type="checkbox"/>
GEO THERMAL	<input type="checkbox"/>	<input type="checkbox"/>	<input type="checkbox"/>	<input type="checkbox"/>	<input type="checkbox"/>	<input type="checkbox"/>
OUTSIDE	<input type="checkbox"/>	<input type="checkbox"/>	<input type="checkbox"/>	<input type="checkbox"/>	<input type="checkbox"/>	<input type="checkbox"/>
CTRL A/C	<input type="checkbox"/>	<input checked="" type="checkbox"/>	<input type="checkbox"/>	<input type="checkbox"/>	<input type="checkbox"/>	<input type="checkbox"/>

PLUMBING		BASE		<input checked="" type="checkbox"/>
X FULL BATH		1		
X HALF BATH		1		
X FIXTURES				

FLOOR	AREA	CONST	VALUE
1	2157	FR	244,990
BSMT	2157		30,850
SUBTOTAL			275,840
MULTI-FAMILY #	0		0
BUILDING TYPE	100%		0
BSMT FINISH	0 S.F.		0
FIREPLACE #	0		0
HEATING	0 S.F.		0
AIR COND	2,157 S.F.		3,560
PLUMBING #	5		6,050
GARAGES & CARPORTS			25,500
EXTRA FEATURES			13,100
SUBTOTAL			324,050
GRADE FACTOR			105 %
UNADJUSTED VALUE			340,250
FACTOR			100 %

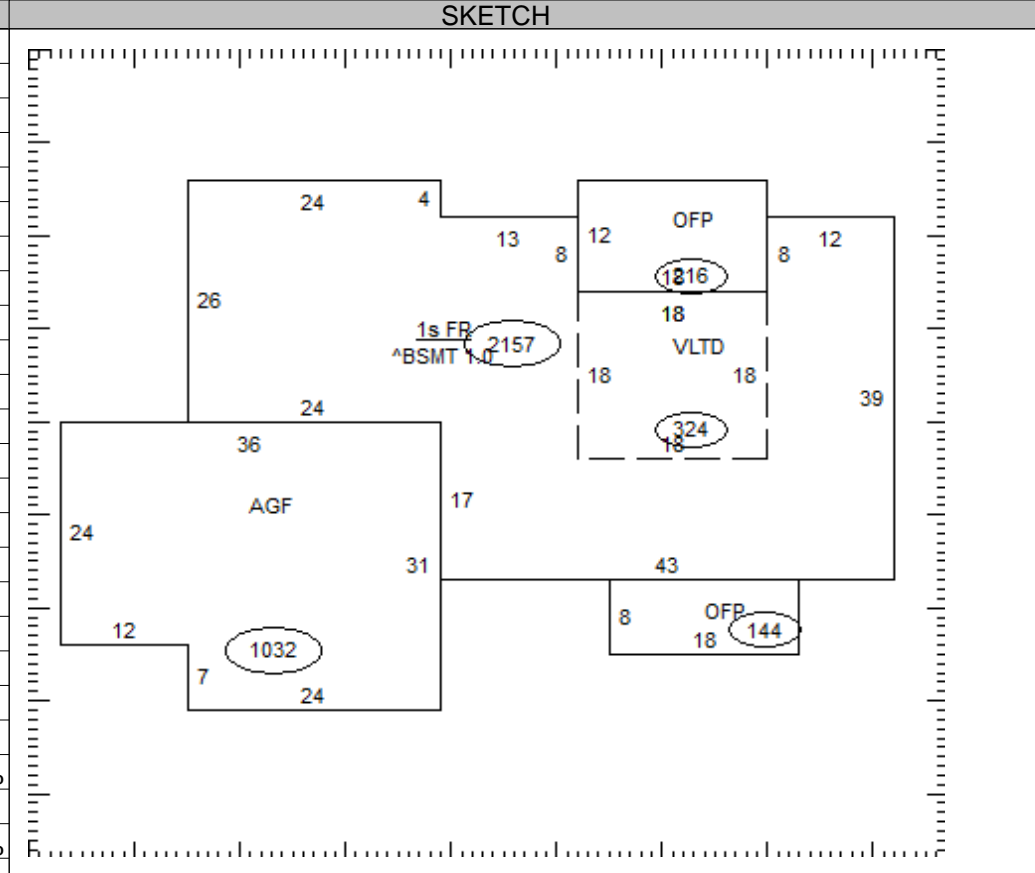

OCCUPANCY	ST.HT	SIZE	AREA	GRADE	PRICE	AGE	REMD	CND	UNADJ VAL	PHYS	PHYS VAL	FUNC	TRUE VAL
DWELLING	1	SK	2,157	C+		2021		G	340,250	2	333,450		366,800
1													
2													
3													
4													
5													
6													
7													
8													
9													
10													
11													

23-075400.2000

TOTAL 366,800

COMMENTS

Dwelling has an Economic Factor of 110%