

23-038200.0000

REICHERT ADAM & BROOK

REICHERT ADAM & BROOK

231 N SYCAMORE ST

SAINT HENRY, OH 45883

LEGAL INFORMATION

ROSE & SCHOCKMAN ADD

AKA OP LOT 74

LOT#: 3

	OWNERSHIP	ADDRESS	CITY	STATE	ZIP	DATE	AMOUNT	DEED:CONV#	JS	VALID
1	REICHERT ADAM & BROOK	231 N SYCAMORE ST	SAINT HENRY	OH	45883	05/05/2023	271,500	2:WDC : 235	<input type="checkbox"/>	<input checked="" type="checkbox"/>
2	LANGENKAMP MICHAEL R	231 N SYCAMORE ST	SAINT HENRY	OH	45883	11/28/2012	150,000	3:WDC : A-M : 760	<input type="checkbox"/>	<input checked="" type="checkbox"/>
3	WOODS TED M & ANGELA R	231 N SYCAMORE ST	ST HENRY	OH	45883	12/02/2002	130,000	: A-M : 0	<input type="checkbox"/>	<input type="checkbox"/>

X:	<input type="checkbox"/> TTO	LISTER: DF	DATE: 03/07/2005	TIME: 12:00:00 AM	<input type="checkbox"/> LETTER	<input type="checkbox"/> LETTER REC'D	GIS CODE
----	------------------------------	------------	------------------	-------------------	---------------------------------	---------------------------------------	----------

STREET/ROAD	TOPOGRAPHY	PU-UTILITIES-PR	NEIGHBORHOOD	INFLUENCE FACTORS				PROPERTY LOCATION
<input checked="" type="checkbox"/> PAVED	<input checked="" type="checkbox"/> LEVEL	<input type="checkbox"/> WATER	<input type="checkbox"/> IMPROVING	<input type="checkbox"/> A. NO ROAD	<input type="checkbox"/> F. RESTRICT	231 N SYCAMORE ST, ST HENRY		
<input type="checkbox"/> GRAVEL	<input type="checkbox"/> HIGH	<input type="checkbox"/> SEWER	<input checked="" type="checkbox"/> STATIC	<input type="checkbox"/> B. TOPGRHY	<input type="checkbox"/> G. WOOD LT	COMMENT		
<input type="checkbox"/> DIRT	<input type="checkbox"/> LOW	<input type="checkbox"/> GAS	<input type="checkbox"/> DECLINING	<input type="checkbox"/> C. Ex Front	<input type="checkbox"/> H. VACANCY	TY2022:Net Gen=\$2,395.90, Other		
<input checked="" type="checkbox"/> SIDEWALKS	<input type="checkbox"/> ROLLING	<input type="checkbox"/> ELECTRIC	<input type="checkbox"/> OLD	<input type="checkbox"/> D. QUANTITY	<input type="checkbox"/> I. WATER FRONT	Assessment=\$0.00		
<input type="checkbox"/> CURBS	<input type="checkbox"/> STANDARD	<input checked="" type="checkbox"/> STANDARD	<input type="checkbox"/> STANDARD	<input type="checkbox"/> E. SZ/SHAPE	<input type="checkbox"/> J. OTHER/CDU	de13 rmv 2.5% rb/ owner didn't ret app		

LAND COMPUTATIONS

LAND TYPE	SIZE	M	RATE	C	INF	M	VALUE	C
F:Front	F75 D116	ST385	DP87	ADJ335			25,100	0
TOTAL							25,100	0

VALUATION SUMMARY

VALUE YEAR	2023	2020	2017				
REASON FOR CHANGE	RAPP	RAPP	RAPP				
APPRAISED	LAND	25,100	20,100	17,000			
VALUE	IMPR	186,400	158,700	128,400			
	TOTAL	211,500	178,800	145,400			
ASSESSED	LAND	8,790	7,040	5,950			
VALUE	IMPR	65,240	55,550	44,940			
	TOTAL	74,030	62,590	50,890			

OCCUPANCY		EXTERIOR		FLOOR	AREA	CONST	VALUE
<input checked="" type="checkbox"/> SF	<input type="checkbox"/> DU	<input type="checkbox"/> TR	<input checked="" type="checkbox"/> WOOD	1	1168	BRK	188,300
<input type="checkbox"/> CONVERSION			<input type="checkbox"/> STUCCO	.25	292	BRK	42,940
BUILDING TYPE							
<input type="checkbox"/> MOBILE HOME			<input type="checkbox"/> ALM/VYNL				
<input type="checkbox"/> BI/TR LEVEL			<input type="checkbox"/> CONC BLK				
<input type="checkbox"/> MOD/MAN			<input type="checkbox"/> METAL				
<input type="checkbox"/> _____			<input checked="" type="checkbox"/> BRICK				
			<input type="checkbox"/> STONE				
ROOFING		ROOF TYPE					
<input type="checkbox"/> METAL			<input type="checkbox"/> GABLE				
<input type="checkbox"/> SLT/TLE			<input type="checkbox"/> HIP				
<input checked="" type="checkbox"/> SHINGLES			<input type="checkbox"/> GAMBREL				
<input type="checkbox"/> SHAKES			<input type="checkbox"/> MANSARD				
<input type="checkbox"/> COMPOSITE			<input type="checkbox"/> FLAT				
FLOORS		B	1	2	3	U	
CONCRETE		<input checked="" type="checkbox"/>	<input type="checkbox"/>	<input type="checkbox"/>	<input type="checkbox"/>	<input type="checkbox"/>	
WOOD		<input type="checkbox"/>	<input type="checkbox"/>	<input type="checkbox"/>	<input type="checkbox"/>	<input type="checkbox"/>	
TILE/COMPO		<input type="checkbox"/>	<input type="checkbox"/>	<input type="checkbox"/>	<input type="checkbox"/>	<input type="checkbox"/>	
CARPET		<input checked="" type="checkbox"/>	<input checked="" type="checkbox"/>	<input checked="" type="checkbox"/>	<input type="checkbox"/>	<input type="checkbox"/>	
INT. FINISH		B	1	2	3	U	
PLASTER/DW		<input type="checkbox"/>	<input checked="" type="checkbox"/>	<input checked="" type="checkbox"/>	<input type="checkbox"/>	<input type="checkbox"/>	
PANELING		<input checked="" type="checkbox"/>	<input type="checkbox"/>	<input type="checkbox"/>	<input type="checkbox"/>	<input type="checkbox"/>	
UNFINISHED		<input checked="" type="checkbox"/>	<input type="checkbox"/>	<input type="checkbox"/>	<input type="checkbox"/>	<input type="checkbox"/>	
ACCOMMODATIONS							
# OF ROOMS	3	5	1				
BEDROOMS		2	1				
FIREPLACES		1					
HEAT & AC		B	1	2	3	U	
NO HEAT		<input type="checkbox"/>	<input type="checkbox"/>	<input type="checkbox"/>	<input type="checkbox"/>	<input type="checkbox"/>	
CTRL HEAT		<input checked="" type="checkbox"/>	<input checked="" type="checkbox"/>	<input checked="" type="checkbox"/>	<input type="checkbox"/>	<input type="checkbox"/>	
HW/STEAM		<input checked="" type="checkbox"/>	<input checked="" type="checkbox"/>	<input checked="" type="checkbox"/>	<input type="checkbox"/>	<input type="checkbox"/>	
ELECTRIC		<input type="checkbox"/>	<input type="checkbox"/>	<input type="checkbox"/>	<input type="checkbox"/>	<input type="checkbox"/>	
HEAT PUMP		<input type="checkbox"/>	<input type="checkbox"/>	<input type="checkbox"/>	<input type="checkbox"/>	<input type="checkbox"/>	
FLR/WALL		<input type="checkbox"/>	<input type="checkbox"/>	<input type="checkbox"/>	<input type="checkbox"/>	<input type="checkbox"/>	
STVE/SPCE		<input type="checkbox"/>	<input type="checkbox"/>	<input type="checkbox"/>	<input type="checkbox"/>	<input type="checkbox"/>	
GEOTHERMAL		<input type="checkbox"/>	<input type="checkbox"/>	<input type="checkbox"/>	<input type="checkbox"/>	<input type="checkbox"/>	
OUTSIDE		<input type="checkbox"/>	<input type="checkbox"/>	<input type="checkbox"/>	<input type="checkbox"/>	<input type="checkbox"/>	
CTRL A/C		<input type="checkbox"/>	<input checked="" type="checkbox"/>	<input checked="" type="checkbox"/>	<input type="checkbox"/>	<input type="checkbox"/>	
PLUMBING		BASE			<input checked="" type="checkbox"/>		
X FULL BATH		1					
X HALF BATH		1					
X FIXTURES							

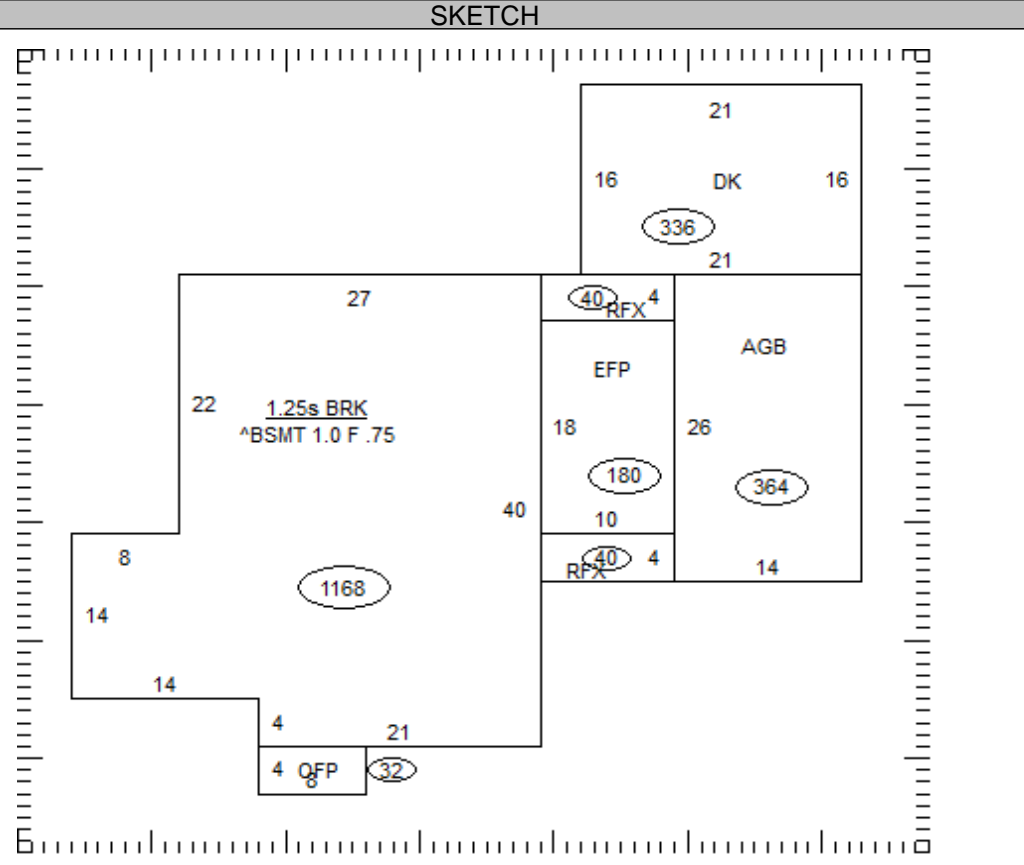

BSMT	1168		16,700
SUBTOTAL			247,940
MULTI-FAMILY #	0		0
BUILDING TYPE	100%		0
BSMT FINISH	876 S.F.		12,530
FIREPLACE #	1		4,400
HEATING	0 S.F.		0
AIR COND	1,460 S.F.		2,410
PLUMBING #	5		6,050
GARAGES & CARPORTS			10,200
EXTRA FEATURES			9,900
SUBTOTAL			293,430
GRADE FACTOR			105 %
UNADJUSTED VALUE			308,100
FACTOR			100 %

OCCUPANCY	ST.HT	SIZE	AREA	GRADE	PRICE	AGE	REMD	CND	UNADJ VAL	PHYS	PHYS VAL	FUNC	TRUE VAL
DWELLING	1.25	SK	1,460	C+		1952		A	308,100	45	169,460		186,400
1													
2													
3													
4													
5													
6													
7													
8													
9													
10													
11													

23-038200.0000 TOTAL 186,400

COMMENTS

Dwelling has an Economic Factor of 110%