



23-001600.0000

**PRICE TIMOTHY J & JEANINE A**  
PRICE TIMOTHY J & JEANINE A  
441 E KREMER HOYING RD  
SAINT HENRY, OH 45883

**LEGAL INFORMATION**  
PT SW SE  
UNPLATTED AREA  
RTS: 002-07-16

	OWNERSHIP	ADDRESS	CITY	STATE	ZIP	DATE	AMOUNT	DEED:CONV#	JS	VALID
1	PRICE TIMOTHY J & JEANINE A	441 E KREMER HOYING RD	SAINT HENRY	OH	45883	07/12/2021	200,000	WDC : 545	<input type="checkbox"/>	<input checked="" type="checkbox"/>
2	WEITZEL SCOTT N &	441 E KREMER HOYING RD	SAINT HENRY	OH	45883	10/31/2014	140,000	WDC : 756	<input type="checkbox"/>	<input checked="" type="checkbox"/>
3	BERNARD MARY L	441 E KREMER HOYING RD	SAINT HENRY	OH	45883	02/29/2008	0	QCE : X : 0	<input type="checkbox"/>	<input type="checkbox"/>

X:  TTO LISTER: HK DATE: 03/19/2020 TIME: 12:00:00 AM  LETTER  LETTER REC'D GIS CODE

STREET/ROAD	TOPOGRAPHY	PU-UTILITIES-PR	NEIGHBORHOOD	INFLUENCE FACTORS	PROPERTY LOCATION
<input checked="" type="checkbox"/> PAVED	<input checked="" type="checkbox"/> LEVEL	<input type="checkbox"/> WATER <input type="checkbox"/>	<input type="checkbox"/> IMPROVING	<input type="checkbox"/> A. NO ROAD <input type="checkbox"/> F. RESTRICT	441 E KREMER HOYING RD, ST HENRY
<input type="checkbox"/> GRAVEL	<input type="checkbox"/> HIGH	<input type="checkbox"/> SEWER <input type="checkbox"/>	<input checked="" type="checkbox"/> STATIC	<input type="checkbox"/> B. TOPGRHY <input type="checkbox"/> G. WOOD LT	COMMENT
<input type="checkbox"/> DIRT	<input type="checkbox"/> LOW	<input type="checkbox"/> GAS <input type="checkbox"/>	<input type="checkbox"/> DECLINING	<input type="checkbox"/> C. Ex Front <input type="checkbox"/> H. VACANCY	TY2022:Net Gen=\$1,921.62, Other
<input type="checkbox"/> SIDEWALKS	<input type="checkbox"/> ROLLING	<input type="checkbox"/> ELECTRIC <input type="checkbox"/>	<input type="checkbox"/> OLD	<input type="checkbox"/> D. QUANTITY <input type="checkbox"/> I. WATER FRONT	Assessment=\$0.00
<input type="checkbox"/> CURBS	<input type="checkbox"/> STANDARD	<input checked="" type="checkbox"/> STANDARD	<input type="checkbox"/> STANDARD	<input type="checkbox"/> E. SZ/SHAPE <input type="checkbox"/> J. OTHER/CDU	DE20 TTO; NO SHED TO BE BUILT

**LAND COMPUTATIONS**

LAND TYPE	SIZE	M	RATE	C	INF	M	VALUE	C
F:Front	F80 D150	ST385	DP100	ADJ385			30,800	0
					TOTAL		30,800	0

TY2022:Net Gen=\$1,921.62, Other  
Assessment=\$0.00  
DE20 TTO; NO SHED TO BE BUILT  
DE16 DESK TOP REVIEW//CORR SKETCH  
DE17 REVAL: ADJ NBHD; UPDATE VAL HISTORY

**VALUATION SUMMARY**

VALUE YEAR	2023	2020	2017
REASON FOR CHANGE	RAPP	RAPP	MISC
APPRAISED VALUE	30,800	24,500	20,800
	IMPR	118,900	94,200
	TOTAL	143,400	115,000
ASSESSED VALUE	10,780	8,580	7,280
	IMPR	41,620	32,970
	TOTAL	50,200	40,250

<b>OCCUPANCY</b>		<b>EXTERIOR</b>		<b>FLOOR</b>	<b>AREA</b>	<b>CONST</b>	<b>VALUE</b>
<input checked="" type="checkbox"/> SF	<input type="checkbox"/> DU	<input type="checkbox"/> TR	<input type="checkbox"/> WOOD	1	1072	FR	167,210
<input type="checkbox"/> CONVERSION			<input type="checkbox"/> STUCCO	.25	216	FR	30,730
<b>BUILDING TYPE</b>			<input checked="" type="checkbox"/> ALM/VYNL				
<input type="checkbox"/> MOBILE HOME			<input type="checkbox"/> CONC BLK				
<input type="checkbox"/> BI/TR LEVEL			<input type="checkbox"/> METAL				
<input type="checkbox"/> MOD/MAN			<input type="checkbox"/> BRICK				
<input type="checkbox"/>			<input type="checkbox"/> STONE				

<b>ROOFING</b>		<b>ROOF TYPE</b>	
<input type="checkbox"/> METAL			<input checked="" type="checkbox"/> GABLE
<input type="checkbox"/> SLT/TLE			<input type="checkbox"/> HIP
<input checked="" type="checkbox"/> SHINGLES			<input type="checkbox"/> GAMBREL
<input type="checkbox"/> SHAKES			<input type="checkbox"/> MANSARD
<input type="checkbox"/> COMPOSITE			<input type="checkbox"/> FLAT

<b>FLOORS</b>		<b>B</b>	<b>1</b>	<b>2</b>	<b>3</b>	<b>U</b>
CONCRETE		<input checked="" type="checkbox"/>	<input type="checkbox"/>	<input type="checkbox"/>	<input type="checkbox"/>	<input type="checkbox"/>
WOOD		<input type="checkbox"/>	<input checked="" type="checkbox"/>	<input checked="" type="checkbox"/>	<input type="checkbox"/>	<input type="checkbox"/>
TILE/COMPO		<input type="checkbox"/>	<input type="checkbox"/>	<input type="checkbox"/>	<input type="checkbox"/>	<input type="checkbox"/>
CARPET		<input type="checkbox"/>	<input type="checkbox"/>	<input type="checkbox"/>	<input type="checkbox"/>	<input type="checkbox"/>
<b>INT. FINISH</b>		<b>B</b>	<b>1</b>	<b>2</b>	<b>3</b>	<b>U</b>
PLASTER/DW		<input type="checkbox"/>	<input checked="" type="checkbox"/>	<input checked="" type="checkbox"/>	<input type="checkbox"/>	<input type="checkbox"/>
PANELING		<input type="checkbox"/>	<input type="checkbox"/>	<input type="checkbox"/>	<input type="checkbox"/>	<input type="checkbox"/>
UNFINISHED		<input checked="" type="checkbox"/>	<input type="checkbox"/>	<input type="checkbox"/>	<input type="checkbox"/>	<input type="checkbox"/>
<b>ACCOMMODATIONS</b>						
# OF ROOMS			4	2		
BEDROOMS			2	2		
FIREPLACES						
<b>HEAT &amp; AC</b>		<b>B</b>	<b>1</b>	<b>2</b>	<b>3</b>	<b>U</b>
NO HEAT		<input type="checkbox"/>	<input type="checkbox"/>	<input type="checkbox"/>	<input type="checkbox"/>	<input type="checkbox"/>
CTRL HEAT		<input type="checkbox"/>	<input checked="" type="checkbox"/>	<input checked="" type="checkbox"/>	<input type="checkbox"/>	<input type="checkbox"/>
HW/STEAM		<input type="checkbox"/>	<input type="checkbox"/>	<input type="checkbox"/>	<input type="checkbox"/>	<input type="checkbox"/>
ELECTRIC		<input type="checkbox"/>	<input type="checkbox"/>	<input type="checkbox"/>	<input type="checkbox"/>	<input type="checkbox"/>
HEAT PUMP		<input type="checkbox"/>	<input type="checkbox"/>	<input type="checkbox"/>	<input type="checkbox"/>	<input type="checkbox"/>
FLR/WALL		<input type="checkbox"/>	<input type="checkbox"/>	<input type="checkbox"/>	<input type="checkbox"/>	<input type="checkbox"/>
STVE/SPCE		<input type="checkbox"/>	<input type="checkbox"/>	<input type="checkbox"/>	<input type="checkbox"/>	<input type="checkbox"/>
GEOTHERMAL		<input type="checkbox"/>	<input type="checkbox"/>	<input type="checkbox"/>	<input type="checkbox"/>	<input type="checkbox"/>
OUTSIDE		<input type="checkbox"/>	<input type="checkbox"/>	<input type="checkbox"/>	<input type="checkbox"/>	<input type="checkbox"/>
CTRL A/C		<input type="checkbox"/>	<input checked="" type="checkbox"/>	<input checked="" type="checkbox"/>	<input type="checkbox"/>	<input type="checkbox"/>
<b>PLUMBING</b>		<b>BASE</b> <input checked="" type="checkbox"/>				
X FULL BATH			1			
X HALF BATH						
X FIXTURES						

BSMT	864		12,360
<b>SUBTOTAL</b>			210,300
MULTI-FAMILY #	0		0
BUILDING TYPE	100%		0
BSMT FINISH	0 S.F.		0
FIREPLACE #	0		0
HEATING	0 S.F.		0
AIR COND	1,288 S.F.		2,130
PLUMBING #	3		3,630
<b>GARAGES &amp; CARPORTS</b>			13,100
<b>EXTRA FEATURES</b>			4,000
<b>SUBTOTAL</b>			233,160
<b>GRADE FACTOR</b>			100 %
<b>UNADJUSTED VALUE</b>			233,160
<b>FACTOR</b>			100 %

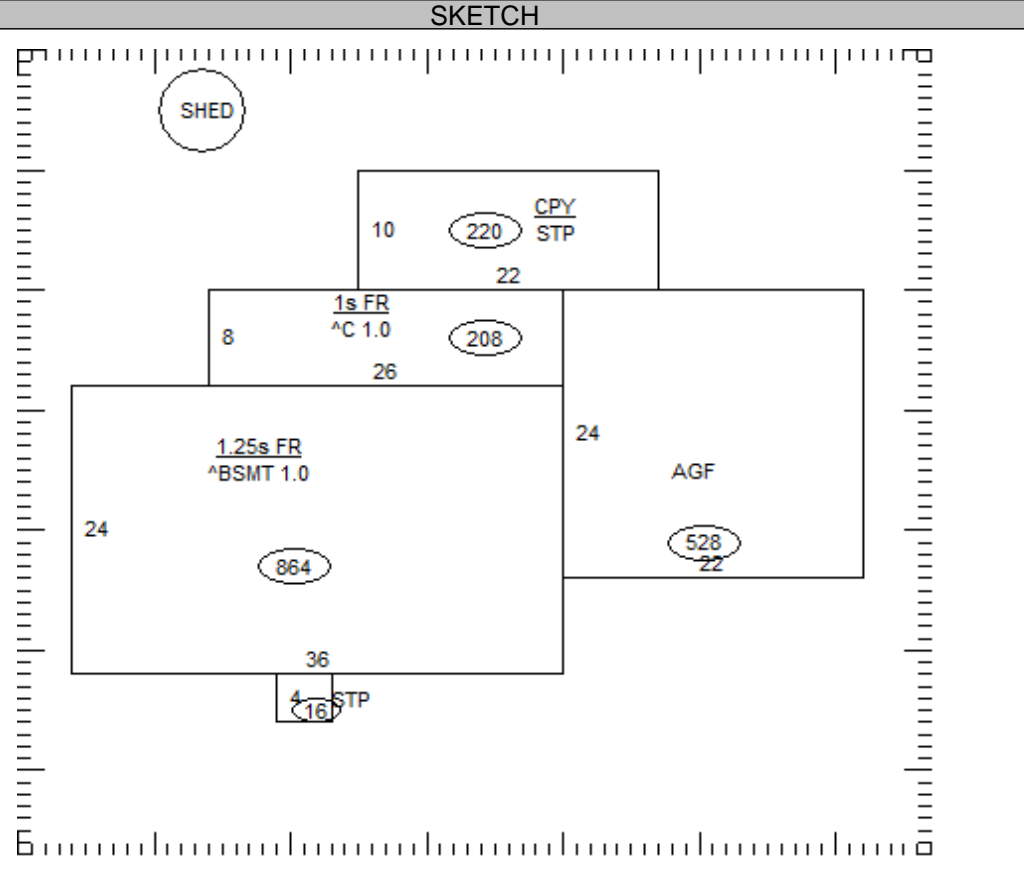

OCCUPANCY	ST.HT	SIZE	AREA	GRADE	PRICE	AGE	REMD	CND	UNADJ VAL	PHYS	PHYS VAL	FUNC	TRUE VAL
DWELLING	1.25	SK	1,288	C		1954		A	233,160	42	135,230		148,800
1 Shed		8x10	80	C		2014		A		13			0
2													
3													
4													
5													
6													
7													
8													
9													
10													
11													

23-001600.0000	<b>TOTAL</b>	148,800
----------------	--------------	---------

**COMMENTS**

Dwelling has an Economic Factor of 110%

GRANVILLE TWP-ST HENRY CORP / ST HENRY SD  
11-16-456-013

Property Class: 510  
Neighborhood  
002302-TM50  
Map: 04A4  
Block:  
Card: 83  
Bk: Pg:

23-001600.0000

**PRICE TIMOTHY J & JEANINE A**  
PRICE TIMOTHY J & JEANINE A  
441 E KREMER HOYING RD  
SAINT HENRY, OH 45883

**LEGAL INFORMATION**  
PT SW SE  
UNPLATTED AREA  
RTS: 002-07-16

	OWNERSHIP	ADDRESS	CITY	STATE	ZIP	DATE	AMOUNT	DEED:CONV#	JS	VALID
1	BERNARD ELMER	441 KREMER HOYING RD	ST HENRY	OH	45883		0	:0	<input type="checkbox"/>	<input type="checkbox"/>
2							0	0	<input type="checkbox"/>	<input type="checkbox"/>
3							0	0	<input type="checkbox"/>	<input type="checkbox"/>

X:  TTO LISTER: HK DATE: 03/19/2020 TIME: 12:00:00 AM  LETTER  LETTER REC'D GIS CODE

STREET/ROAD	TOPOGRAPHY	PU-UTILITIES-PR	NEIGHBORHOOD	INFLUENCE FACTORS	PROPERTY LOCATION	
<input checked="" type="checkbox"/> PAVED <input type="checkbox"/> GRAVEL <input type="checkbox"/> DIRT <input type="checkbox"/> SIDEWALKS <input type="checkbox"/> CURBS	<input checked="" type="checkbox"/> LEVEL <input type="checkbox"/> HIGH <input type="checkbox"/> LOW <input type="checkbox"/> ROLLING <input type="checkbox"/> STANDARD	<input type="checkbox"/> WATER <input type="checkbox"/> SEWER <input type="checkbox"/> GAS <input type="checkbox"/> ELECTRIC <input checked="" type="checkbox"/> STANDARD	<input type="checkbox"/> IMPROVING <input checked="" type="checkbox"/> STATIC <input type="checkbox"/> DECLINING <input type="checkbox"/> OLD <input type="checkbox"/> STANDARD	<input type="checkbox"/> A. NO ROAD <input type="checkbox"/> B. TOPGRHY <input type="checkbox"/> C. Ex Front <input type="checkbox"/> D. QUANTITY <input type="checkbox"/> E. SZ/SHAPE	<input type="checkbox"/> F. RESTRICT <input type="checkbox"/> G. WOOD LT <input type="checkbox"/> H. VACANCY <input type="checkbox"/> I. WATER FRONT <input type="checkbox"/> J. OTHER/CDU	441 E KREMER HOYING RD, ST HENRY COMMENT

LAND COMPUTATIONS							
LAND TYPE	SIZE	M	RATE	C	INF	M	VALUE C
TOTAL						30,800	0

**VALUATION SUMMARY**

VALUE YEAR	REASON FOR CHANGE	APPRaised	IMPR	TOTAL	ASSESSED	IMPR	TOTAL

**OCCUPANCY**  
 SF  DU  TR  
 CONVERSION

**BUILDING TYPE**  
 MOBILE HOME  
 BI/TR LEVEL  
 MOD/MAN  
 \_\_\_\_\_

**EXTERIOR**  
 WOOD  
 STUCCO  
 ALM/VYNL  
 CONC BLK  
 METAL  
 BRICK  
 STONE

**ROOFING**

**ROOF TYPE**  
 GABLE  
 HIP  
 GAMBREL  
 MANSARD  
 FLAT

**FLOORS** B 1 2 3 U

CONCRETE       
WOOD       
TILE/COMPO       
CARPET

**INT. FINISH** B 1 2 3 U

PLASTER/DW       
PANELING       
UNFINISHED

**ACCOMMODATIONS**

# OF ROOMS          
BEDROOMS          
FIREPLACES  

**HEAT & AC** B 1 2 3 U

NO HEAT       
CTRL HEAT       
HW/STEAM       
ELECTRIC       
HEAT PUMP       
FLR/WALL       
STVE/SPCE       
GEOTHERMAL       
OUTSIDE       
CTRL A/C

**PLUMBING** BASE

X FULL BATH       
X HALF BATH       
X FIXTURES

FLOOR	AREA	CONST	VALUE

<b>SUBTOTAL</b>		0
MULTI-FAMILY #	0	0
BUILDING TYPE	000%	0
BSMT FINISH	0 S.F.	0
FIREPLACE #	0	0
HEATING	0 S.F.	0
AIR COND	0 S.F.	0
PLUMBING #	0	0
GARAGES & CARPORTS		0
EXTRA FEATURES		0
<b>SUBTOTAL</b>		0
GRADE FACTOR		%
<b>UNADJUSTED VALUE</b>		0
<b>FACTOR</b>		%

OCCUPANCY	ST.HT	SIZE	AREA	GRADE	PRICE	AGE	REMD	CND	UNADJ VAL	PHYS	PHYS VAL	FUNC	TRUE VAL
DWELLING		SK											
1													
2													
3													
4													
5													
6													
7													
8													
9													
10													
11													

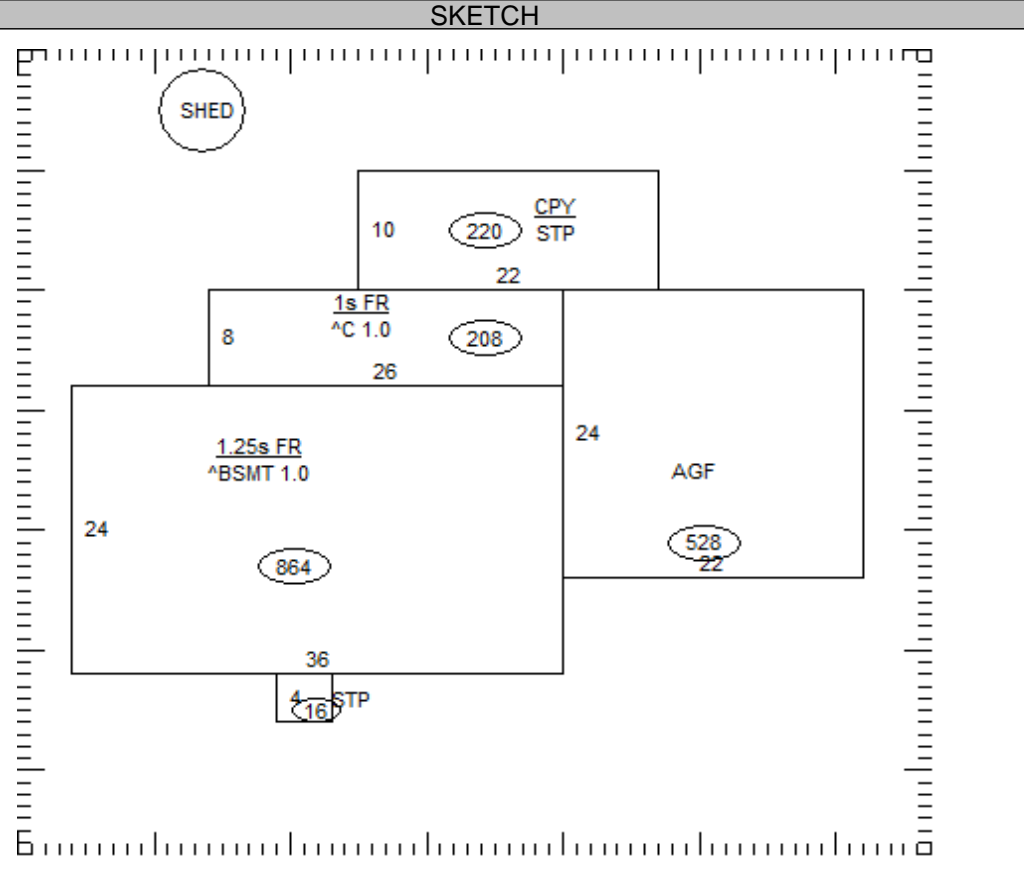

23-001600.0000

TOTAL 0

**COMMENTS**