

20-045700.0000

STEINLAGE MARK A & LESLIE A

STEINLAGE MARK A & LESLIE A  
3831 FT RECOVERY MINSTER RD  
SAINT HENRY, OH 45883

LEGAL INFORMATION

W1/2 SE

RTS: 002-07-29  
Acres:2.5300

	OWNERSHIP	ADDRESS	CITY	STATE	ZIP	DATE	AMOUNT	DEED:CONV#	JS	VALID
1	STEINLAGE MARK A & LESLIE	3831 FT RECOVERY	SAINT HENRY	OH	45883	04/30/2020	295,000	WDC : 262	<input type="checkbox"/>	<input checked="" type="checkbox"/>
2	JUTTE SYLVAN R & JEANETTE	3831 FT RECOVERY	ST HENRY	OH	45883	01/01/1900	0	: 0	<input type="checkbox"/>	<input type="checkbox"/>
3							0	0	<input type="checkbox"/>	<input type="checkbox"/>

X:  TTO LISTER: HK DATE: 02/22/2022 TIME: 12:00:00 AM  LETTER  LETTER REC'D GIS CODE

STREET/ROAD	TOPOGRAPHY	PU-UTILITIES-PR	NEIGHBORHOOD	INFLUENCE FACTORS				PROPERTY LOCATION
<input checked="" type="checkbox"/> PAVED	<input checked="" type="checkbox"/> LEVEL	<input type="checkbox"/> WATER	<input type="checkbox"/> IMPROVING	<input type="checkbox"/> A. NO ROAD	<input type="checkbox"/> F. RESTRICT	3831 FT REC MINSTER RD, ST HENRY		
<input type="checkbox"/> GRAVEL	<input type="checkbox"/> HIGH	<input type="checkbox"/> SEWER	<input type="checkbox"/> STATIC	<input type="checkbox"/> B. TOPGRHY	<input type="checkbox"/> G. WOOD LT	COMMENT		
<input type="checkbox"/> DIRT	<input type="checkbox"/> LOW	<input type="checkbox"/> GAS	<input type="checkbox"/> DECLINING	<input type="checkbox"/> C. Ex Front	<input type="checkbox"/> H. VACANCY	TY2022:Net Gen=\$4,395.70, Other		
<input type="checkbox"/> SIDEWALKS	<input type="checkbox"/> ROLLING	<input type="checkbox"/> ELECTRIC	<input type="checkbox"/> OLD	<input type="checkbox"/> D. QUANTITY	<input type="checkbox"/> I. WATER FRONT	Assessment=\$0.88		
<input type="checkbox"/> CURBS	<input type="checkbox"/> STANDARD	<input checked="" type="checkbox"/> STANDARD	<input type="checkbox"/> STANDARD	<input type="checkbox"/> E. SZ/SHAPE	<input type="checkbox"/> J. OTHER/CDU	DE21 ADD 1.5 BATHS, GAS FP, EX FIX		

LAND COMPUTATIONS						
LAND TYPE	SIZE	M	RATE	C	INF	M VALUE C
HS:Home Site	AC:1	32050				32,100 0
SM:Small Acreage	AC:1.53	8300				12,700 0
Total Acres: 2.5300					TOTAL	44,800 0

VALUATION SUMMARY									
VALUE YEAR	2023	2022	2021	2021	2021	2020	2020	2020	
REASON FOR CHANGE	RAPP	MISC	NC	MISC	RCLS	CAUV	RAPP	CAUV	
APPRAISED	LAND	44,800	30,400	30,400	30,400	30,150	17,550	28,700	18,880
VALUE	IMPR	368,800	307,200	185,000	174,800	174,800	144,600	144,600	140,300
	TOTAL	413,600	337,600	215,400	205,200	204,950	162,150	173,300	159,180
ASSESSED	LAND	15,680	10,640	10,640	10,640	10,550	6,140	10,050	6,610
VALUE	IMPR	129,080	107,520	64,750	61,180	61,180	50,610	50,610	49,110
	TOTAL	144,760	118,160	75,390	71,820	71,730	56,750	60,660	55,720

<b>OCCUPANCY</b>		<b>EXTERIOR</b>	
<input checked="" type="checkbox"/> SF	<input type="checkbox"/> DU	<input type="checkbox"/> WOOD	<input type="checkbox"/> STUCCO
<input type="checkbox"/> TR	<input type="checkbox"/> CONVERSION	<input type="checkbox"/> ALM/VYNL	<input type="checkbox"/> CONC BLK
<b>BUILDING TYPE</b>		<input type="checkbox"/> METAL	<input checked="" type="checkbox"/> BRICK
<input type="checkbox"/> MOBILE HOME	<input type="checkbox"/> BI/TR LEVEL	<input type="checkbox"/> GAMBREL	<input type="checkbox"/> STONE
<input type="checkbox"/> MOD/MAN	<input type="checkbox"/>	<input type="checkbox"/> MANSARD	
<input type="checkbox"/>		<input type="checkbox"/> FLAT	

<b>ROOFING</b>		<b>ROOF TYPE</b>	
<input type="checkbox"/> METAL	<input type="checkbox"/> SLT/TLE	<input type="checkbox"/> GABLE	<input type="checkbox"/> HIP
<input checked="" type="checkbox"/> SHINGLES	<input type="checkbox"/> SHAKES	<input type="checkbox"/> GAMBREL	<input type="checkbox"/> MANSARD
<input type="checkbox"/>	<input type="checkbox"/> COMPOSITE	<input type="checkbox"/> FLAT	

<b>FLOORS</b>		B	1	2	3	U
CONCRETE	<input checked="" type="checkbox"/>	<input type="checkbox"/>	<input type="checkbox"/>	<input type="checkbox"/>	<input type="checkbox"/>	<input type="checkbox"/>
WOOD	<input type="checkbox"/>	<input checked="" type="checkbox"/>	<input type="checkbox"/>	<input type="checkbox"/>	<input type="checkbox"/>	<input type="checkbox"/>
TILE/COMPO	<input type="checkbox"/>	<input type="checkbox"/>	<input type="checkbox"/>	<input type="checkbox"/>	<input type="checkbox"/>	<input type="checkbox"/>
CARPET	<input type="checkbox"/>	<input type="checkbox"/>	<input type="checkbox"/>	<input type="checkbox"/>	<input type="checkbox"/>	<input type="checkbox"/>

<b>INT. FINISH</b>		B	1	2	3	U
PLASTER/DW	<input type="checkbox"/>	<input checked="" type="checkbox"/>	<input type="checkbox"/>	<input type="checkbox"/>	<input type="checkbox"/>	<input type="checkbox"/>
PANELING	<input type="checkbox"/>	<input type="checkbox"/>	<input type="checkbox"/>	<input type="checkbox"/>	<input type="checkbox"/>	<input type="checkbox"/>
UNFINISHED	<input checked="" type="checkbox"/>	<input type="checkbox"/>	<input type="checkbox"/>	<input type="checkbox"/>	<input type="checkbox"/>	<input type="checkbox"/>

<b>ACCOMMODATIONS</b>						
# OF ROOMS		7				
BEDROOMS		3				
FIREPLACES		1				

<b>HEAT &amp; AC</b>		B	1	2	3	U
NO HEAT	<input type="checkbox"/>	<input type="checkbox"/>	<input type="checkbox"/>	<input type="checkbox"/>	<input type="checkbox"/>	<input type="checkbox"/>
CTRL HEAT	<input type="checkbox"/>	<input checked="" type="checkbox"/>	<input type="checkbox"/>	<input type="checkbox"/>	<input type="checkbox"/>	<input type="checkbox"/>
HW/STEAM	<input type="checkbox"/>	<input type="checkbox"/>	<input type="checkbox"/>	<input type="checkbox"/>	<input type="checkbox"/>	<input type="checkbox"/>
ELECTRIC	<input type="checkbox"/>	<input type="checkbox"/>	<input type="checkbox"/>	<input type="checkbox"/>	<input type="checkbox"/>	<input type="checkbox"/>
HEAT PUMP	<input type="checkbox"/>	<input checked="" type="checkbox"/>	<input type="checkbox"/>	<input type="checkbox"/>	<input type="checkbox"/>	<input type="checkbox"/>
FLR/WALL	<input type="checkbox"/>	<input type="checkbox"/>	<input type="checkbox"/>	<input type="checkbox"/>	<input type="checkbox"/>	<input type="checkbox"/>
STVE/SPCE	<input type="checkbox"/>	<input type="checkbox"/>	<input type="checkbox"/>	<input type="checkbox"/>	<input type="checkbox"/>	<input type="checkbox"/>
GEO THERMAL	<input type="checkbox"/>	<input type="checkbox"/>	<input type="checkbox"/>	<input type="checkbox"/>	<input type="checkbox"/>	<input type="checkbox"/>
OUTSIDE	<input type="checkbox"/>	<input type="checkbox"/>	<input type="checkbox"/>	<input type="checkbox"/>	<input type="checkbox"/>	<input type="checkbox"/>
CTRL A/C	<input type="checkbox"/>	<input checked="" type="checkbox"/>	<input type="checkbox"/>	<input type="checkbox"/>	<input type="checkbox"/>	<input type="checkbox"/>

<b>PLUMBING</b>		<b>BASE</b>		<input checked="" type="checkbox"/>
X FULL BATH		1		
X HALF BATH		1		
X FIXTURES		1		

FLOOR	AREA	CONST	VALUE
1	2594	BRK	299,240
BSMT	1694		24,220
<b>SUBTOTAL</b>			323,460
MULTI-FAMILY #	0		0
BUILDING TYPE	100%		0
BSMT FINISH	0 S.F.		0
FIREPLACE #	1		4,400
HEATING	0 S.F.		0
AIR COND	2,594 S.F.		4,280
PLUMBING #	6		7,260
GARAGES & CARPORTS			16,000
EXTRA FEATURES			5,100
<b>SUBTOTAL</b>			360,500
GRADE FACTOR			105 %
<b>UNADJUSTED VALUE</b>			378,530
FACTOR			100 %

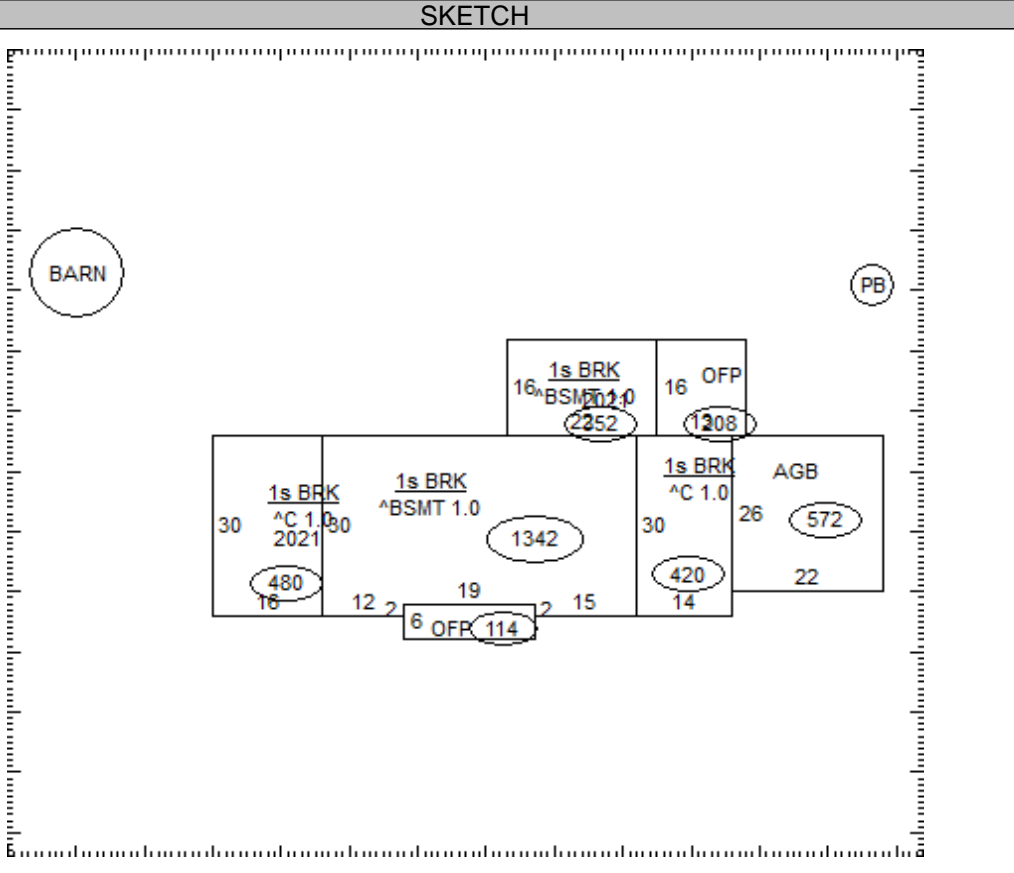

OCCUPANCY	ST.HT	SIZE	AREA	GRADE	PRICE	AGE	REMD	CND	UNADJ VAL	PHYS	PHYS VAL	FUNC	TRUE VAL
DWELLING	1	SK	2,594	C+		1964	2021	A	378,530	22	295,250		354,300
1 Barn	16	44x90	3,960	D	9.60	1900	2021	A	38,020	95	1,900		1,900
2 Pole Bldg	14	48x80	3,840	C	14.25	1982	2018	A	54,720	77	12,590		12,600
3													
4													
5													
6													
7													
8													
9													
10													
11													

20-045700.0000

TOTAL 368,800

**COMMENTS**

HEAT : ELEC/BB/CC  
 >>OB Features: 1.2 <Add Concrete Floor>  
 Dwelling has an Economic Factor of 120% (Rollback Basis=\$386,400)

GRANVILLE TWP / ST HENRY SD

11-29-400-001

Property Class: 510  
Neighborhood  
009205-R150

Map: 17A  
Block:  
Card: 19

Bk: Pg:

20-045700.0000

**STEINLAGE MARK A & LESLIE A**

STEINLAGE MARK A & LESLIE A  
3831 FT RECOVERY MINSTER RD  
SAINT HENRY, OH 45883

**LEGAL INFORMATION**

W1/2 SE

RTS: 002-07-29  
Acres: 2.5300

	OWNERSHIP	ADDRESS	CITY	STATE	ZIP	DATE	AMOUNT	DEED:CONV#	JS	VALID
1	STEINLAGE MARK A & LESLIE	3831 FT RECOVERY	SAINT HENRY	OH	45883	04/30/2020	295,000	WDC : 262	<input type="checkbox"/>	<input checked="" type="checkbox"/>
2	JUTTE SYLVAN R & JEANETTE	3831 FT RECOVERY	ST HENRY	OH	45883	01/01/1900	0	: 0	<input type="checkbox"/>	<input type="checkbox"/>
3							0	0	<input type="checkbox"/>	<input type="checkbox"/>

X:  TTO LISTER: HK DATE: 02/22/2022 TIME: 12:00:00 AM  LETTER  LETTER REC'D GIS CODE

**STREET/ROAD TOPOGRAPHY PU-UTILITIES-PR NEIGHBORHOOD INFLUENCE FACTORS PROPERTY LOCATION**

PAVED  LEVEL  WATER  IMPROVING  A. NO ROAD  F. RESTRICT  
 GRAVEL  HIGH  SEWER  STATIC  B. TOPGRHY  G. WOOD LT  
 DIRT  LOW  GAS  DECLINING  C. Ex Front  H. VACANCY  
 SIDEWALKS  ROLLING  ELECTRIC  OLD  D. QUANTITY  I. WATER FRONT  
 CURBS  STANDARD  STANDARD  STANDARD  E. SZ/SHAPE  J. OTHER/CDU

3831 FT REC MINSTER RD, ST HENRY

**COMMENT**

**LAND COMPUTATIONS**

LAND TYPE	SIZE	M	RATE	C	INF	M	VALUE	C
Total Acres: 2.5300					TOTAL		44,800	0

**VALUATION SUMMARY**

VALUE YEAR	REASON FOR CHANGE	2020	2018	2018	2017	2017		
		MISC	CAUV	MISC	CAUV	RAPP		
APPRaised	<u>LAND</u>	30,550	130,810	597,350	134,600	597,350		
VALUE	<u>IMPR</u>	140,300	140,300	140,300	140,100	140,100		
	<u>TOTAL</u>	170,850	271,110	737,650	274,700	737,450		
ASSESSed	<u>LAND</u>	10,690	45,780	209,070	47,110	209,070		
VALUE	<u>IMPR</u>	49,110	49,110	49,110	49,040	49,040		
	<u>TOTAL</u>	59,800	94,890	258,180	96,150	258,110		

OCCUPANCY	EXTERIOR	FLOOR	AREA	CONST	VALUE
<input type="checkbox"/> SF <input type="checkbox"/> DU <input type="checkbox"/> TR	<input type="checkbox"/> WOOD				
<input type="checkbox"/> CONVERSION	<input type="checkbox"/> STUCCO				
<b>BUILDING TYPE</b>	<input type="checkbox"/> ALM/VYNL				
<input type="checkbox"/> MOBILE HOME	<input type="checkbox"/> CONC BLK				
<input type="checkbox"/> BI/TR LEVEL	<input type="checkbox"/> METAL				
<input type="checkbox"/> MOD/MAN	<input type="checkbox"/> BRICK				
<input type="checkbox"/>	<input type="checkbox"/> STONE				
ROOFING	ROOF TYPE				
<input type="checkbox"/> METAL	<input type="checkbox"/> GABLE				
<input type="checkbox"/> SLT/TLE	<input type="checkbox"/> HIP				
<input type="checkbox"/> SHINGLES	<input type="checkbox"/> GAMBREL				
<input type="checkbox"/> SHAKES	<input type="checkbox"/> MANSARD				
<input type="checkbox"/> COMPOSITE	<input type="checkbox"/> FLAT				

<b>SUBTOTAL</b>		0
MULTI-FAMILY #	0	0
BUILDING TYPE	000%	0
BSMT FINISH	0 S.F.	0
FIREPLACE #	0	0
HEATING	0 S.F.	0
AIR COND	0 S.F.	0
PLUMBING #	0	0
GARAGES & CARPORTS		0
EXTRA FEATURES		0
<b>SUBTOTAL</b>		0
GRADE FACTOR		%
<b>UNADJUSTED VALUE</b>		0
FACTOR		%

FLOORS	B	1	2	3	U
CONCRETE	<input type="checkbox"/>	<input type="checkbox"/>	<input type="checkbox"/>	<input type="checkbox"/>	<input type="checkbox"/>
WOOD	<input type="checkbox"/>	<input type="checkbox"/>	<input type="checkbox"/>	<input type="checkbox"/>	<input type="checkbox"/>
TILE/COMPO	<input type="checkbox"/>	<input type="checkbox"/>	<input type="checkbox"/>	<input type="checkbox"/>	<input type="checkbox"/>
CARPET	<input type="checkbox"/>	<input type="checkbox"/>	<input type="checkbox"/>	<input type="checkbox"/>	<input type="checkbox"/>
INT. FINISH	B	1	2	3	U
PLASTER/DW	<input type="checkbox"/>	<input type="checkbox"/>	<input type="checkbox"/>	<input type="checkbox"/>	<input type="checkbox"/>
PANELING	<input type="checkbox"/>	<input type="checkbox"/>	<input type="checkbox"/>	<input type="checkbox"/>	<input type="checkbox"/>
UNFINISHED	<input type="checkbox"/>	<input type="checkbox"/>	<input type="checkbox"/>	<input type="checkbox"/>	<input type="checkbox"/>
ACCOMMODATIONS					
# OF ROOMS					
BEDROOMS					
FIREPLACES					
HEAT & AC	B	1	2	3	U
NO HEAT	<input type="checkbox"/>	<input type="checkbox"/>	<input type="checkbox"/>	<input type="checkbox"/>	<input type="checkbox"/>
CTRL HEAT	<input type="checkbox"/>	<input type="checkbox"/>	<input type="checkbox"/>	<input type="checkbox"/>	<input type="checkbox"/>
HW/STEAM	<input type="checkbox"/>	<input type="checkbox"/>	<input type="checkbox"/>	<input type="checkbox"/>	<input type="checkbox"/>
ELECTRIC	<input type="checkbox"/>	<input type="checkbox"/>	<input type="checkbox"/>	<input type="checkbox"/>	<input type="checkbox"/>
HEAT PUMP	<input type="checkbox"/>	<input type="checkbox"/>	<input type="checkbox"/>	<input type="checkbox"/>	<input type="checkbox"/>
FLR/WALL	<input type="checkbox"/>	<input type="checkbox"/>	<input type="checkbox"/>	<input type="checkbox"/>	<input type="checkbox"/>
STVE/SPCE	<input type="checkbox"/>	<input type="checkbox"/>	<input type="checkbox"/>	<input type="checkbox"/>	<input type="checkbox"/>
GEOHERMAL	<input type="checkbox"/>	<input type="checkbox"/>	<input type="checkbox"/>	<input type="checkbox"/>	<input type="checkbox"/>
OUTSIDE	<input type="checkbox"/>	<input type="checkbox"/>	<input type="checkbox"/>	<input type="checkbox"/>	<input type="checkbox"/>
CTRL A/C	<input type="checkbox"/>	<input type="checkbox"/>	<input type="checkbox"/>	<input type="checkbox"/>	<input type="checkbox"/>
PLUMBING		BASE <input type="checkbox"/>			
X FULL BATH					
X HALF BATH					
X FIXTURES					

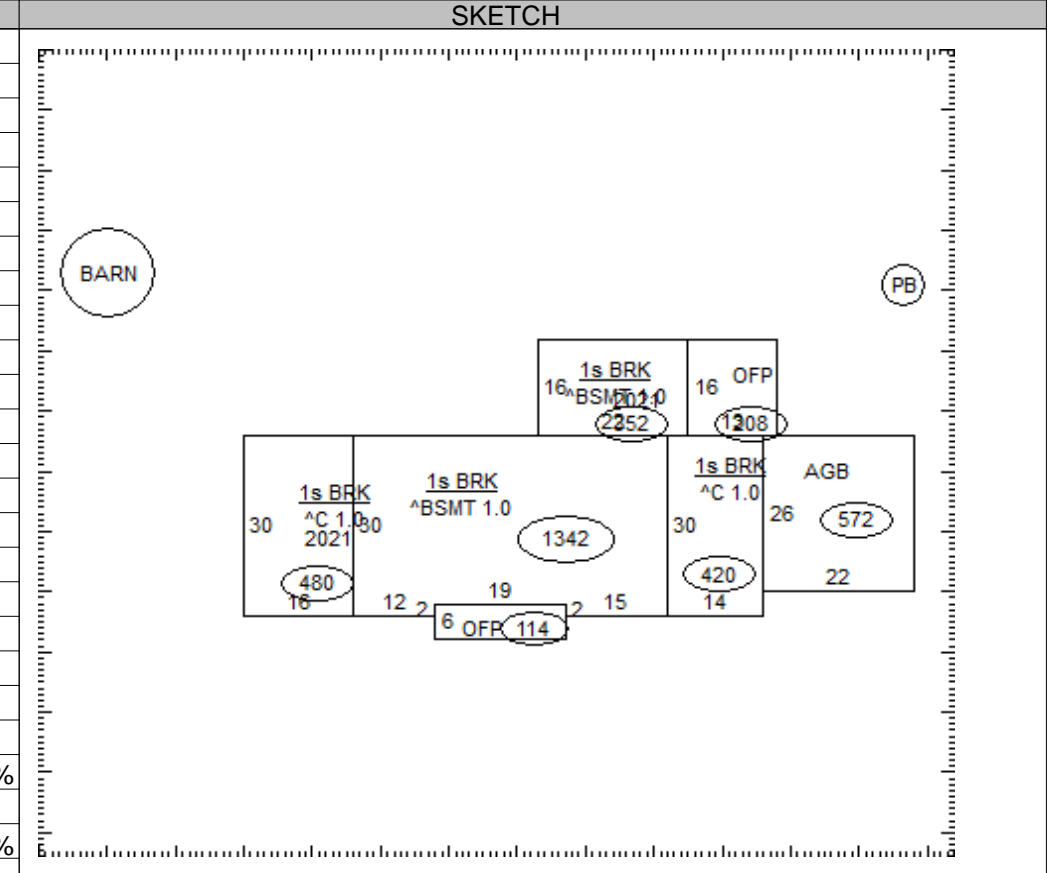

OCCUPANCY	ST.HT	SIZE	AREA	GRADE	PRICE	AGE	REMD	CND	UNADJ VAL	PHYS	PHYS VAL	FUNC	TRUE VAL
DWELLING		SK											
1													
2													
3													
4													
5													
6													
7													
8													
9													
10													
11													

20-045700.0000

TOTAL 0

COMMENTS