



20-043900.0100

UNRAST MARK D
UNRAST MARK D

1967 ST RTE 118

SAINT HENRY, OH 45883

Created in 2020 From 20-043900.0000 due to Split

LEGAL INFORMATION
PT NE NE

RTS: 002-07-28
Acres:3.8350

	OWNERSHIP	ADDRESS	CITY	STATE	ZIP	DATE	AMOUNT	DEED:CONV#	JS	VALID
1	UNRAST MARK D	1967 ST RTE 118	SAINT HENRY	OH	45883	09/11/2020	360,000	WDC : 657	<input type="checkbox"/>	<input checked="" type="checkbox"/>
2							0	0	<input type="checkbox"/>	<input type="checkbox"/>
3							0	0	<input type="checkbox"/>	<input type="checkbox"/>

X: TTO LISTER: DATE: TIME: LETTER LETTER REC'D GIS CODE

STREET/ROAD TOPOGRAPHY PU-UTILITIES-PR NEIGHBORHOOD INFLUENCE FACTORS PROPERTY LOCATION

PAVED LEVEL WATER IMPROVING A. NO ROAD F. RESTRICT 1967 ST RTE 118
 GRAVEL HIGH SEWER STATIC B. TOPGRHY G. WOOD LT
 DIRT LOW GAS DECLINING C. Ex Front H. VACANCY
 SIDEWALKS ROLLING ELECTRIC OLD D. QUANTITY I. WATER FRONT
 CURBS STANDARD STANDARD E. SZ/SHAPE J. OTHER/CDU

COMMENT
TY2022:Net Gen=\$2,167.66, Other Assessment=\$0.30
DE22 DESKTOP RVW; RMV SILO STAVE
DE23 NO LONGER QUALIFIES CAUV/

LAND COMPUTATIONS

LAND TYPE	SIZE	M	RATE	C	INF	M	VALUE	C
HS:Home Site	AC:1	32050				32,100	0	
SM:Small Acreage	AC:2.835	8100				23,000	0	
Total Acres: 3.8350						TOTAL	55,100	0

VALUATION SUMMARY

VALUE YEAR	2023	2023	2023	2022	2022	2021	2021
REASON FOR CHANGE	RAPP	MISC	RCLS	CAUV	REMB	CAUV	MISC
APPRAISED	55,100	39,700	42,870	18,840	42,230	18,840	42,230
VALUE	IMPR	202,600	171,800	171,800	144,100	144,600	144,600
	TOTAL	257,700	211,500	214,670	162,940	186,330	186,830
ASSESSED	LAND	19,290	13,900	15,000	6,590	14,780	14,780
VALUE	IMPR	70,910	60,130	60,130	50,440	50,610	50,610
	TOTAL	90,200	74,030	75,130	57,030	65,390	65,390

OCCUPANCY	EXTERIOR	FLOOR	AREA	CONST	VALUE
<input checked="" type="checkbox"/> SF <input type="checkbox"/> DU <input type="checkbox"/> TR	<input checked="" type="checkbox"/> WOOD	1	1428	FR	197,250
<input type="checkbox"/> CONVERSION	<input type="checkbox"/> STUCCO	.5	320	FR	27,410
BUILDING TYPE	<input checked="" type="checkbox"/> ALM/VYNL	+	0	FR	3,480
<input type="checkbox"/> MOBILE HOME	<input type="checkbox"/> CONC BLK				
<input type="checkbox"/> BI/TR LEVEL	<input type="checkbox"/> METAL				
<input type="checkbox"/> MOD/MAN	<input type="checkbox"/> BRICK				
<input type="checkbox"/>	<input type="checkbox"/> STONE				
ROOFING	ROOF TYPE				
<input type="checkbox"/> METAL	<input checked="" type="checkbox"/> GABLE				
<input type="checkbox"/> SLT/TLE	<input type="checkbox"/> HIP				
<input checked="" type="checkbox"/> SHINGLES	<input type="checkbox"/> GAMBREL				
<input type="checkbox"/> SHAKES	<input type="checkbox"/> MANSARD				
<input type="checkbox"/> COMPOSITE	<input type="checkbox"/> FLAT				
FLOORS	B 1 2 3 U	BSMT	260		3,720
CONCRETE	<input checked="" type="checkbox"/> <input type="checkbox"/> <input type="checkbox"/> <input type="checkbox"/> <input type="checkbox"/>	SUBTOTAL			231,860
WOOD	<input type="checkbox"/> <input checked="" type="checkbox"/> <input checked="" type="checkbox"/> <input type="checkbox"/> <input type="checkbox"/>	MULTI-FAMILY #	0		0
TILE/COMPO	<input type="checkbox"/> <input type="checkbox"/> <input type="checkbox"/> <input type="checkbox"/> <input type="checkbox"/>	BUILDING TYPE	100%		0
CARPET	<input type="checkbox"/> <input checked="" type="checkbox"/> <input checked="" type="checkbox"/> <input type="checkbox"/> <input type="checkbox"/>	BSMT FINISH	0 S.F.		0
INT. FINISH	B 1 2 3 U	FIREPLACE #	0		0
PLASTER/DW	<input type="checkbox"/> <input checked="" type="checkbox"/> <input checked="" type="checkbox"/> <input type="checkbox"/> <input type="checkbox"/>	HEATING	0 S.F.		0
PANELING	<input type="checkbox"/> <input type="checkbox"/> <input type="checkbox"/> <input type="checkbox"/> <input type="checkbox"/>	AIR COND	0 S.F.		0
UNFINISHED	<input type="checkbox"/> <input type="checkbox"/> <input type="checkbox"/> <input type="checkbox"/> <input type="checkbox"/>	PLUMBING #	1		1,210
ACCOMMODATIONS		GARAGES & CARPORTS			16,700
# OF ROOMS		EXTRA FEATURES			2,700
BEDROOMS		SUBTOTAL			252,470
FIREPLACES		GRADE FACTOR			100 %
HEAT & AC		UNADJUSTED VALUE			252,470
		FACTOR			100 %

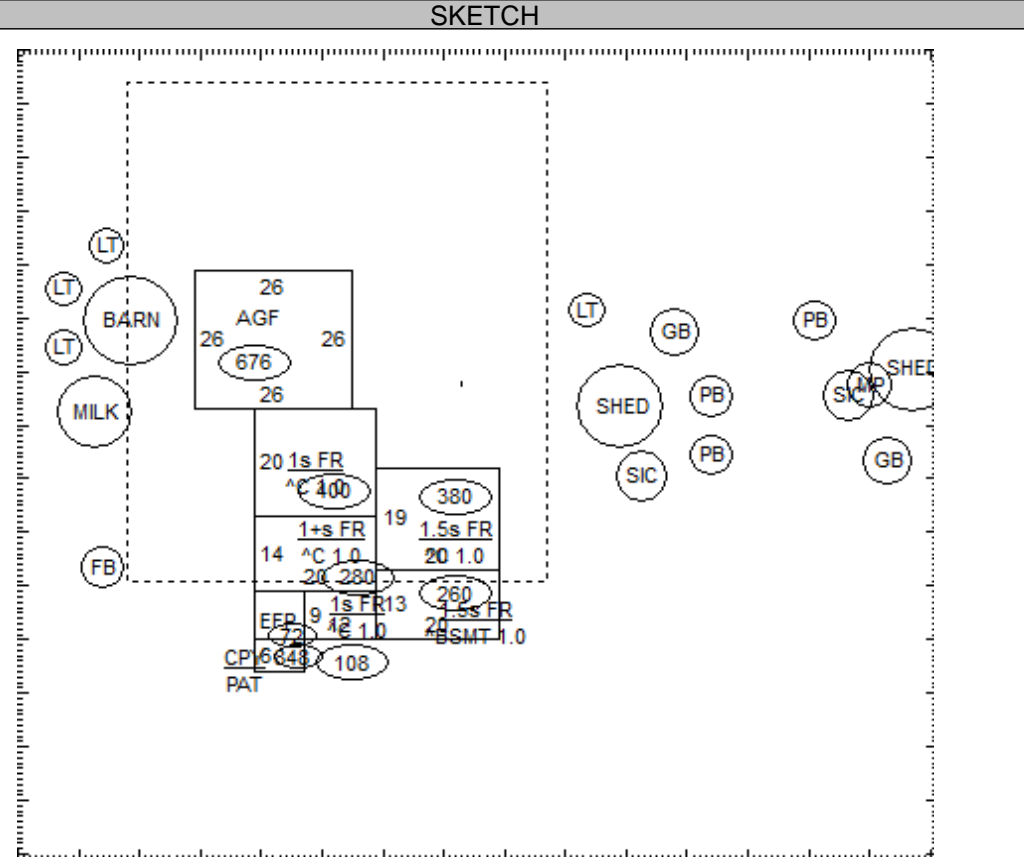

OCCUPANCY	ST.HT	SIZE	AREA	GRADE	PRICE	AGE	REMD	CND	UNADJ VAL	PHYS	PHYS VAL	FUNC	TRUE VAL
DWELLING	1.5	SK	1,748	C		1900		A	252,470	45	138,860		166,600
1 Feed Bunk		0x0	2,900	C	37.45	1960		F	108,610	90	10,860		10,900
2 Lean - To	8	16x20	320	C	4.80	1900		F	1,540	95	80		100
3 Lean - To	8	10x75	750	C	4.80	1900		A	3,600	95	180		200
4 Silo - Concrete	64	64x18	1,152	C	750.00	1979		A	750		750		800
5 Lean - To	8	23x68	1,564	C	4.80	1900		A	7,510	95	380		400
6 Man Pit		32x95	3,040	C		1900		A		95			0
7 Grain Bin	10	10x16	160	C		1900		A		95			0
8 Grain Bin	16	16x24	384	C		1970		A		85			0
9 Pole Bldg	14	40x56	2,240	C	11.87	1976		A	26,590	80	5,320		5,300
10 Lean - To	8	17x52	884	C	4.80	1900		A	4,240	95	210		200
11 Milk House / Par	10	17x50	850	C	18.00	1950		A	15,300	95	770		800

20-043900.0100 TOTAL 185,300

COMMENTS

Dwelling has an Economic Factor of 120%

20-043900.0100

LEGAL INFORMATION

PT NE NE

RTS: 002-07-28

Acres:3.8350

UNRAST MARK D

UNRAST MARK D

1967 ST RTE 118

SAINT HENRY, OH 45883

Created in 2020 From 20-043900.0000 due to Split

	OWNERSHIP	ADDRESS	CITY	STATE	ZIP	DATE	AMOUNT	DEED:CONV#	JS	VALID
1	UNRAST MARK D	1967 ST RTE 118	SAINT HENRY	OH	45883	09/11/2020	360,000	WDC : 657	<input type="checkbox"/>	<input checked="" type="checkbox"/>
2							0	0	<input type="checkbox"/>	<input type="checkbox"/>
3							0	0	<input type="checkbox"/>	<input type="checkbox"/>

X: TTO LISTER: DATE: TIME: LETTER LETTER REC'D GIS CODE

STREET/ROAD TOPOGRAPHY PU-UTILITIES-PR NEIGHBORHOOD INFLUENCE FACTORS PROPERTY LOCATION

PAVED LEVEL WATER IMPROVING A. NO ROAD F. RESTRICT
 GRAVEL HIGH SEWER STATIC B. TOPGRHY G. WOOD LT
 DIRT LOW GAS DECLINING C. Ex Front H. VACANCY
 SIDEWALKS ROLLING ELECTRIC OLD D. QUANTITY I. WATER FRONT
 CURBS STANDARD STANDARD E. SZ/SHAPE J. OTHER/CDU

1967 ST RTE 118
COMMENT

LAND COMPUTATIONS

LAND TYPE	SIZE	M	RATE	C	INF	M	VALUE	C
Total Acres: 3.8350						TOTAL	55,100	0

VALUATION SUMMARY

VALUE YEAR	REASON FOR CHANGE	APPRaised	IMPR	TOTAL	ASSESSED	IMPR	TOTAL

<input type="checkbox"/> SF <input type="checkbox"/> DU <input type="checkbox"/> TR	<input type="checkbox"/> WOOD
<input type="checkbox"/> CONVERSION	<input type="checkbox"/> STUCCO
BUILDING TYPE	<input type="checkbox"/> ALM/VYNL
<input type="checkbox"/> MOBILE HOME	<input type="checkbox"/> CONC BLK
<input type="checkbox"/> BI/TR LEVEL	<input type="checkbox"/> METAL
<input type="checkbox"/> MOD/MAN	<input type="checkbox"/> BRICK
<input type="checkbox"/>	<input type="checkbox"/> STONE

ROOFING	ROOF TYPE
<input type="checkbox"/> METAL	<input type="checkbox"/> GABLE
<input type="checkbox"/> SLT/TLE	<input type="checkbox"/> HIP
<input type="checkbox"/> SHINGLES	<input type="checkbox"/> GAMBREL
<input type="checkbox"/> SHAKES	<input type="checkbox"/> MANSARD
<input type="checkbox"/> COMPOSITE	<input type="checkbox"/> FLAT

FLOORS	B	1	2	3	U
CONCRETE	<input type="checkbox"/>	<input type="checkbox"/>	<input type="checkbox"/>	<input type="checkbox"/>	<input type="checkbox"/>
WOOD	<input type="checkbox"/>	<input type="checkbox"/>	<input type="checkbox"/>	<input type="checkbox"/>	<input type="checkbox"/>
TILE/COMPO	<input type="checkbox"/>	<input type="checkbox"/>	<input type="checkbox"/>	<input type="checkbox"/>	<input type="checkbox"/>
CARPET	<input type="checkbox"/>	<input type="checkbox"/>	<input type="checkbox"/>	<input type="checkbox"/>	<input type="checkbox"/>

INT. FINISH	B	1	2	3	U
PLASTER/DW	<input type="checkbox"/>	<input type="checkbox"/>	<input type="checkbox"/>	<input type="checkbox"/>	<input type="checkbox"/>
PANELING	<input type="checkbox"/>	<input type="checkbox"/>	<input type="checkbox"/>	<input type="checkbox"/>	<input type="checkbox"/>
UNFINISHED	<input type="checkbox"/>	<input type="checkbox"/>	<input type="checkbox"/>	<input type="checkbox"/>	<input type="checkbox"/>

ACCOMMODATIONS					
# OF ROOMS					
BEDROOMS					
FIREPLACES					
HEAT & AC	B	1	2	3	U

NO HEAT	<input type="checkbox"/>	<input type="checkbox"/>	<input type="checkbox"/>	<input type="checkbox"/>	<input type="checkbox"/>
CTRL HEAT	<input type="checkbox"/>	<input type="checkbox"/>	<input type="checkbox"/>	<input type="checkbox"/>	<input type="checkbox"/>
HW/STEAM	<input type="checkbox"/>	<input type="checkbox"/>	<input type="checkbox"/>	<input type="checkbox"/>	<input type="checkbox"/>
ELECTRIC	<input type="checkbox"/>	<input type="checkbox"/>	<input type="checkbox"/>	<input type="checkbox"/>	<input type="checkbox"/>
HEAT PUMP	<input type="checkbox"/>	<input type="checkbox"/>	<input type="checkbox"/>	<input type="checkbox"/>	<input type="checkbox"/>
FLR/WALL	<input type="checkbox"/>	<input type="checkbox"/>	<input type="checkbox"/>	<input type="checkbox"/>	<input type="checkbox"/>
STVE/SPCE	<input type="checkbox"/>	<input type="checkbox"/>	<input type="checkbox"/>	<input type="checkbox"/>	<input type="checkbox"/>
GEOHERMAL	<input type="checkbox"/>	<input type="checkbox"/>	<input type="checkbox"/>	<input type="checkbox"/>	<input type="checkbox"/>
OUTSIDE	<input type="checkbox"/>	<input type="checkbox"/>	<input type="checkbox"/>	<input type="checkbox"/>	<input type="checkbox"/>
CTRL A/C	<input type="checkbox"/>	<input type="checkbox"/>	<input type="checkbox"/>	<input type="checkbox"/>	<input type="checkbox"/>

PLUMBING	<input type="checkbox"/>
X FULL BATH	<input type="checkbox"/>
X HALF BATH	<input type="checkbox"/>
X FIXTURES	<input type="checkbox"/>

FLOOR	AREA	CONST	VALUE
SUBTOTAL			0
MULTI-FAMILY #	0		0
BUILDING TYPE	000%		0
BSMT FINISH	0 S.F.		0
FIREPLACE #	0		0
HEATING	0 S.F.		0
AIR COND	0 S.F.		0
PLUMBING #	0		0
GARAGES & CARPORTS			0
EXTRA FEATURES			0
SUBTOTAL			0
GRADE FACTOR			%
UNADJUSTED VALUE			0
FACTOR			%

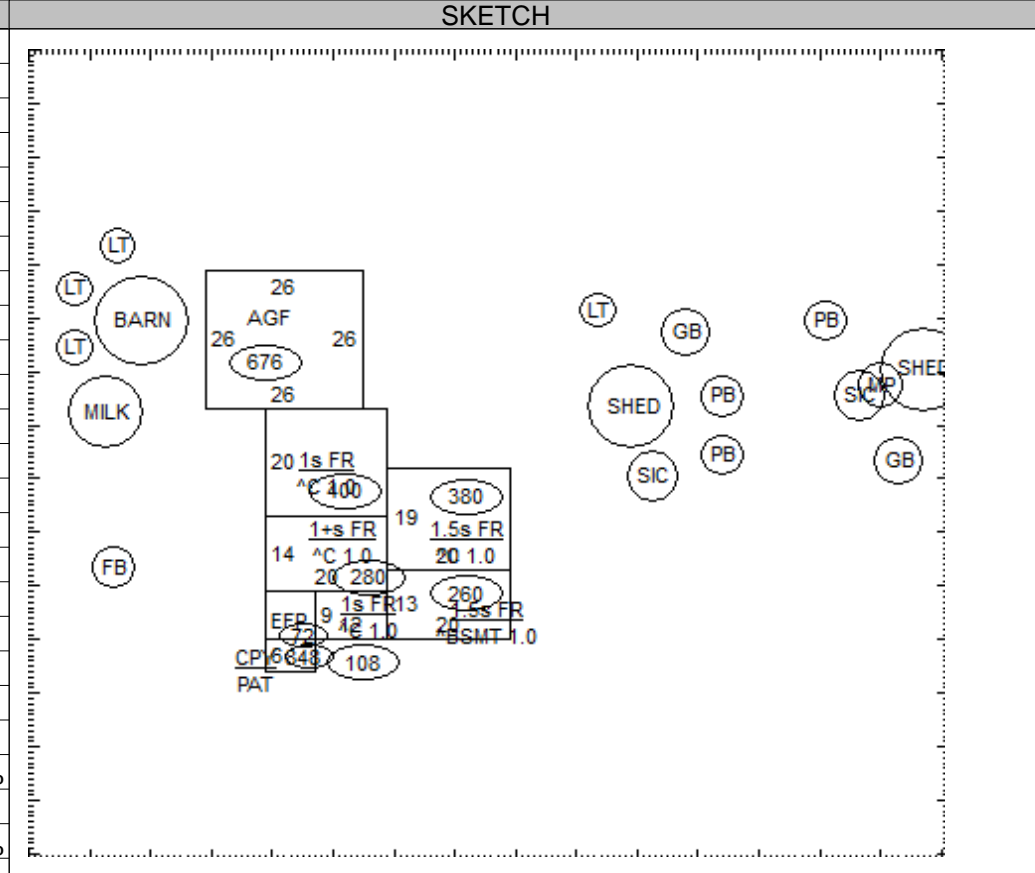

OCCUPANCY	ST.HT	SIZE	AREA	GRADE	PRICE	AGE	REMD	CND	UNADJ VAL	PHYS	PHYS VAL	FUNC	TRUE VAL
DWELLING		SK											
1 Pole Bldg	16	48x80	3,840	C	10.87	1980		A	41,740	77	9,600		9,600
2 Pole Bldg	12	20x40	800	C	14.32	1987		A	11,460	67	3,780		3,800
3 Shed	10	26x50	1,300	C	5.50	1900		A	7,150	95	360		400
4 Barn	14	52x95	4,940	D	9.60	1900		A	47,420	95	2,370		2,400
5 Silo - Concrete	64	64x18	1,152	C	750.00	1975		A	750		750		800
6 Shed		12x14	168	C	9.90	1975		A	1,660	80	330		300
7													
8													
9													
10													
11													

20-043900.0100

TOTAL 17,300

COMMENTS