

GRANVILLE TWP / ST HENRY SD

11-22-400-006

Property Class: 510

Neighborhood

009205-R150

Map: 10

Block:

Card: 28

Bk: Pg:

20-034500.0100

**DORIS JEAN PROPERTIES LLC**

DORIS JEAN PROPERTIES LLC

4419 LANGE RD

SAINT HENRY, OH 45883

**LEGAL INFORMATION**

PT SE SE

RTS: 002-07-22

Acres:1.9380

	OWNERSHIP	ADDRESS	CITY	STATE	ZIP	DATE	AMOUNT	DEED:CONV#	JS	VALID
1	DORIS JEAN PROPERTIES LLC	4419 LANGE RD	SAINT HENRY	OH	45883	09/16/2016	110,000	WDC : 649	<input type="checkbox"/>	<input checked="" type="checkbox"/>
2	MILLER DONALD E & MARY K	4946 ST RTE 119	SAINT HENRY	OH	45883	05/05/2008	0	QCE : X : 0	<input type="checkbox"/>	<input type="checkbox"/>
3	MILLER DONALD E	4946 ST RTE 119	SAINT HENRY	OH	45883	11/08/2005	0	QCE : X : 0	<input type="checkbox"/>	<input type="checkbox"/>

X:  TTO LISTER: JK DATE: 03/26/2018 TIME: 12:00:00 AM  LETTER  LETTER REC'D GIS CODE

STREET/ROAD TOPOGRAPHY PU-UTILITIES-PR NEIGHBORHOOD INFLUENCE FACTORS PROPERTY LOCATION

PAVED  LEVEL  WATER  IMPROVING  A. NO ROAD  F. RESTRICT 4946 ST RT 119, ST HENRY  
 GRAVEL  HIGH  SEWER  STATIC  B. TOPGRHY  G. WOOD LT  
 DIRT  LOW  GAS  DECLINING  C. Ex Front  H. VACANCY  
 SIDEWALKS  ROLLING  ELECTRIC  OLD  D. QUANTITY  I. WATER FRONT  
 CURBS  STANDARD  STANDARD  E. SZ/SHAPE  J. OTHER/CDU

LAND COMPUTATIONS							PROPERTY LOCATION	
LAND TYPE	SIZE	M	RATE	C	INF	M	VALUE	C
HS:Home Site	AC:1	32050				32,100	0	
SM:Small Acreage	AC:0.938	8500				8,000	0	
Total Acres: 1.9380						TOTAL	40,100	0

COMMENT  
 TY2022:Net Gen=\$4,825.28, Other Assessment=\$0.00  
 DE18 TTO; BLDG ON COM PROP (RMV FROM THIS PROP, ADD TO COM 20-034400.0100)  
 DE16 COR ACREAGE PER MAPPING  
 DE17 DESKTOP REVIEW//ADD 2 LT; CORR WD & EFP MSMTS  
 DE17 RMV OWN OCC DUE TO OWNERSHIP  
 DE22 DESKTOP RVW; ADD MACH SHED; ON 2018 AERIALS!

**VALUATION SUMMARY**

VALUE YEAR	2023	2022	2020	2019	2018	2017	2017	
REASON FOR CHANGE	RAPP	NC	RAPP	REMB	NC	RAPP	MISC	
APPRAISED	40,100	26,000	26,000	23,100	23,100	23,100	23,600	
VALUE	IMPR	383,600	336,700	158,900	131,500	278,500	133,200	102,300
	TOTAL	423,700	362,700	184,900	154,600	301,600	156,300	125,900
ASSESSED	LAND	14,040	9,100	9,100	8,090	8,090	8,090	8,260
VALUE	IMPR	134,260	117,850	55,620	46,030	97,480	46,620	35,810
	TOTAL	148,300	126,950	64,720	54,120	105,570	54,710	44,070

**OCCUPANCY**  
 SF  DU  TR  
 CONVERSION  
**BUILDING TYPE**  
 MOBILE HOME  
 BI/TR LEVEL  
 MOD/MAN  
 \_\_\_\_\_

**EXTERIOR**  
 WOOD  
 STUCCO  
 ALM/VYNL  
 CONC BLK  
 METAL  
 BRICK  
 STONE

**ROOFING**  
 METAL  
 SLT/TLE  
 SHINGLES  
 SHAKES  
 COMPOSITE

**ROOF TYPE**  
 GABLE  
 HIP  
 GAMBREL  
 MANSARD  
 FLAT

**FLOORS** B 1 2 3 U  
 CONCRETE       
 WOOD       
 TILE/COMPO       
 CARPET

**INT. FINISH** B 1 2 3 U  
 PLASTER/DW       
 PANELING       
 UNFINISHED

**ACCOMMODATIONS**  
 # OF ROOMS 1 4 3  
 BEDROOMS 1 2  
 FIREPLACES  
 HEAT & AC B 1 2 3 U

NO HEAT       
 CTRL HEAT       
 HW/STEAM       
 ELECTRIC       
 HEAT PUMP       
 FLR/WALL       
 STVE/SPCE       
 GEOTHERMAL       
 OUTSIDE       
 CTRL A/C       
**PLUMBING** BASE   
 X FULL BATH  
 X HALF BATH  
 X FIXTURES

FLOOR	AREA	CONST	VALUE
1	1552	FR	204,100
.5	668	FR	54,470
BSMT	668		9,550
<b>SUBTOTAL</b>			268,120
MULTI-FAMILY #	0		0
BUILDING TYPE	100%		0
BSMT FINISH	0 S.F.		0
FIREPLACE #	0		0
HEATING	0 S.F.		0
AIR COND	2,220 S.F.		3,660
PLUMBING #	0		0
GARAGES & CARPORTS			0
EXTRA FEATURES			8,600
<b>SUBTOTAL</b>			280,380
GRADE FACTOR			100 %
<b>UNADJUSTED VALUE</b>			280,380
FACTOR			100 %

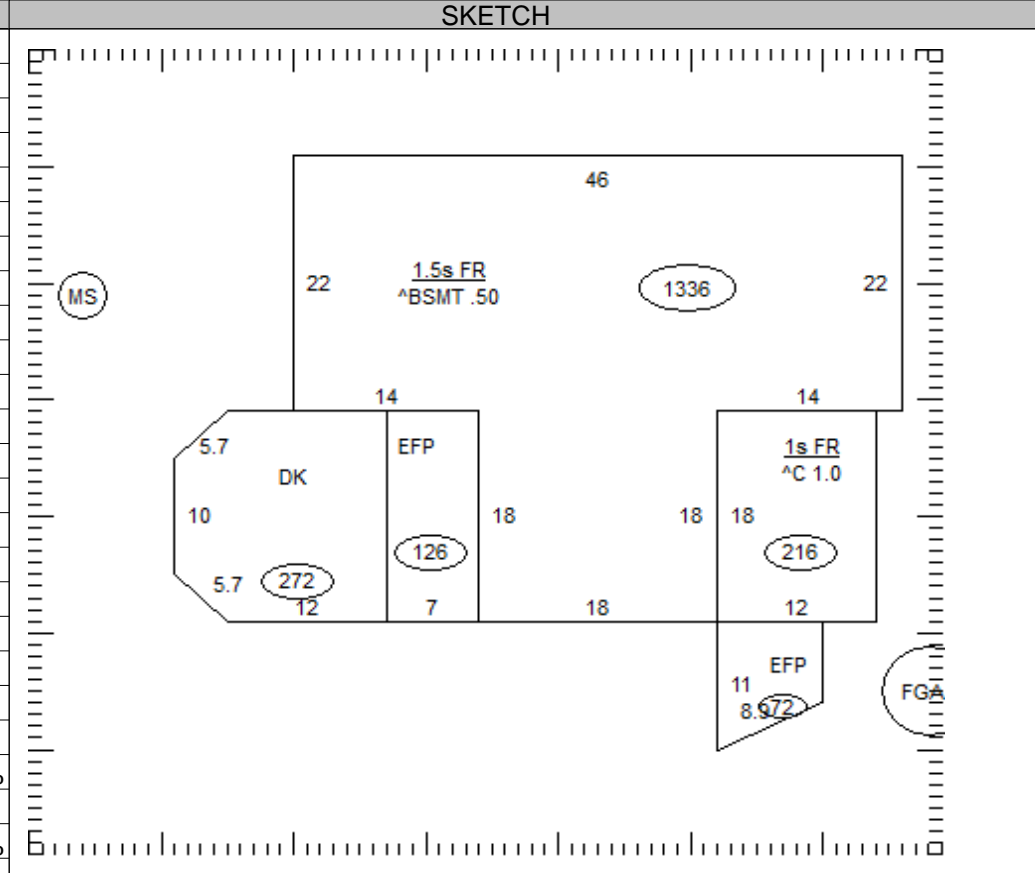

OCCUPANCY	ST.HT	SIZE	AREA	GRADE	PRICE	AGE	REMD	CND	UNADJ VAL	PHYS	PHYS VAL	FUNC	TRUE VAL
DWELLING	1.5	SK	2,220	C		1900		A	280,380	45	154,210		185,100
1 Gar - Frame		24x30	720	C	23.70	1995		A	17,060	47	9,040		9,000
2 Machine Shed	18	80x148	11,840	C	17.21	2017		A	203,770	7	189,510		189,500
3													
4													
5													
6													
7													
8													
9													
10													
11													

20-034500.0100 TOTAL 383,600

**COMMENTS**  
 >>OB Features: 1.2 <Shop/Garage Finish>  
 Dwelling has an Economic Factor of 120%

20-034500.0100

**DORIS JEAN PROPERTIES LLC**  
DORIS JEAN PROPERTIES LLC  
4419 LANGE RD  
SAINT HENRY, OH 45883

**LEGAL INFORMATION**  
PT SE SE

RTS: 002-07-22  
Acres:1.9380

	OWNERSHIP	ADDRESS	CITY	STATE	ZIP	DATE	AMOUNT	DEED:CONV#	JS	VALID
1	MILLER DONALD E & MARY K	4946 ST RT 119	ST HENRY	OH	45883		0	:0	<input type="checkbox"/>	<input type="checkbox"/>
2							0	0	<input type="checkbox"/>	<input type="checkbox"/>
3							0	0	<input type="checkbox"/>	<input type="checkbox"/>

X:  TTO LISTER: JK DATE: 03/26/2018 TIME: 12:00:00 AM  LETTER  LETTER REC'D GIS CODE

STREET/ROAD	TOPOGRAPHY	PU-UTILITIES-PR	NEIGHBORHOOD	INFLUENCE FACTORS	PROPERTY LOCATION	
<input checked="" type="checkbox"/> PAVED <input type="checkbox"/> GRAVEL <input type="checkbox"/> DIRT <input type="checkbox"/> SIDEWALKS <input type="checkbox"/> CURBS	<input checked="" type="checkbox"/> LEVEL <input type="checkbox"/> HIGH <input type="checkbox"/> LOW <input type="checkbox"/> ROLLING <input type="checkbox"/> STANDARD	<input type="checkbox"/> WATER <input type="checkbox"/> SEWER <input checked="" type="checkbox"/> GAS <input checked="" type="checkbox"/> ELECTRIC <input type="checkbox"/> STANDARD	<input type="checkbox"/> IMPROVING <input type="checkbox"/> STATIC <input type="checkbox"/> DECLINING <input type="checkbox"/> OLD <input type="checkbox"/> STANDARD	<input type="checkbox"/> A. NO ROAD <input type="checkbox"/> B. TOPGRHY <input type="checkbox"/> C. Ex Front <input type="checkbox"/> D. QUANTITY <input type="checkbox"/> E. SZ/SHAPE	<input type="checkbox"/> F. RESTRICT <input type="checkbox"/> G. WOOD LT <input type="checkbox"/> H. VACANCY <input type="checkbox"/> I. WATER FRONT <input type="checkbox"/> J. OTHER/CDU	4946 ST RT 119, ST HENRY <b>COMMENT</b>

LAND COMPUTATIONS							
LAND TYPE	SIZE	M	RATE	C	INF	M	VALUE C
Total Acres: 1.9380					TOTAL	40,100	0

**VALUATION SUMMARY**

VALUE YEAR	REASON FOR CHANGE	APPRaised	IMPR	TOTAL	ASSESSED	IMPR	TOTAL

OCCUPANCY	EXTERIOR	FLOOR	AREA	CONST	VALUE
<input type="checkbox"/> SF <input type="checkbox"/> DU <input type="checkbox"/> TR	<input type="checkbox"/> WOOD				
<input type="checkbox"/> CONVERSION	<input type="checkbox"/> STUCCO				
<b>BUILDING TYPE</b>	<input type="checkbox"/> ALM/VYNL				
<input type="checkbox"/> MOBILE HOME	<input type="checkbox"/> CONC BLK				
<input type="checkbox"/> BI/TR LEVEL	<input type="checkbox"/> METAL				
<input type="checkbox"/> MOD/MAN	<input type="checkbox"/> BRICK				
<input type="checkbox"/> _____	<input type="checkbox"/> STONE				

ROOFING	ROOF TYPE
<input type="checkbox"/> METAL	<input type="checkbox"/> GABLE
<input type="checkbox"/> SLT/TLE	<input type="checkbox"/> HIP
<input type="checkbox"/> SHINGLES	<input type="checkbox"/> GAMBREL
<input type="checkbox"/> SHAKES	<input type="checkbox"/> MANSARD
<input type="checkbox"/> COMPOSITE	<input type="checkbox"/> FLAT

FLOORS	B	1	2	3	U
CONCRETE	<input type="checkbox"/>	<input type="checkbox"/>	<input type="checkbox"/>	<input type="checkbox"/>	<input type="checkbox"/>
WOOD	<input type="checkbox"/>	<input type="checkbox"/>	<input type="checkbox"/>	<input type="checkbox"/>	<input type="checkbox"/>
TILE/COMPO	<input type="checkbox"/>	<input type="checkbox"/>	<input type="checkbox"/>	<input type="checkbox"/>	<input type="checkbox"/>
CARPET	<input type="checkbox"/>	<input type="checkbox"/>	<input type="checkbox"/>	<input type="checkbox"/>	<input type="checkbox"/>
INT. FINISH	B	1	2	3	U
PLASTER/DW	<input type="checkbox"/>	<input type="checkbox"/>	<input type="checkbox"/>	<input type="checkbox"/>	<input type="checkbox"/>
PANELING	<input type="checkbox"/>	<input type="checkbox"/>	<input type="checkbox"/>	<input type="checkbox"/>	<input type="checkbox"/>
UNFINISHED	<input type="checkbox"/>	<input type="checkbox"/>	<input type="checkbox"/>	<input type="checkbox"/>	<input type="checkbox"/>
ACCOMMODATIONS					
# OF ROOMS					
BEDROOMS					
FIREPLACES					
HEAT & AC	B	1	2	3	U
NO HEAT	<input type="checkbox"/>	<input type="checkbox"/>	<input type="checkbox"/>	<input type="checkbox"/>	<input type="checkbox"/>
CTRL HEAT	<input type="checkbox"/>	<input type="checkbox"/>	<input type="checkbox"/>	<input type="checkbox"/>	<input type="checkbox"/>
HW/STEAM	<input type="checkbox"/>	<input type="checkbox"/>	<input type="checkbox"/>	<input type="checkbox"/>	<input type="checkbox"/>
ELECTRIC	<input type="checkbox"/>	<input type="checkbox"/>	<input type="checkbox"/>	<input type="checkbox"/>	<input type="checkbox"/>
HEAT PUMP	<input type="checkbox"/>	<input type="checkbox"/>	<input type="checkbox"/>	<input type="checkbox"/>	<input type="checkbox"/>
FLR/WALL	<input type="checkbox"/>	<input type="checkbox"/>	<input type="checkbox"/>	<input type="checkbox"/>	<input type="checkbox"/>
STVE/SPCE	<input type="checkbox"/>	<input type="checkbox"/>	<input type="checkbox"/>	<input type="checkbox"/>	<input type="checkbox"/>
GEO THERMAL	<input type="checkbox"/>	<input type="checkbox"/>	<input type="checkbox"/>	<input type="checkbox"/>	<input type="checkbox"/>
OUTSIDE	<input type="checkbox"/>	<input type="checkbox"/>	<input type="checkbox"/>	<input type="checkbox"/>	<input type="checkbox"/>
CTRL A/C	<input type="checkbox"/>	<input type="checkbox"/>	<input type="checkbox"/>	<input type="checkbox"/>	<input type="checkbox"/>
PLUMBING					BASE <input type="checkbox"/>
X FULL BATH					
X HALF BATH					
X FIXTURES					

<b>SUBTOTAL</b>		0
MULTI-FAMILY #	0	0
BUILDING TYPE	000%	0
BSMT FINISH	0 S.F.	0
FIREPLACE #	0	0
HEATING	0 S.F.	0
AIR COND	0 S.F.	0
PLUMBING #	0	0
GARAGES & CARPORTS		0
EXTRA FEATURES		0
<b>SUBTOTAL</b>		0
GRADE FACTOR		%
<b>UNADJUSTED VALUE</b>		0
FACTOR		%

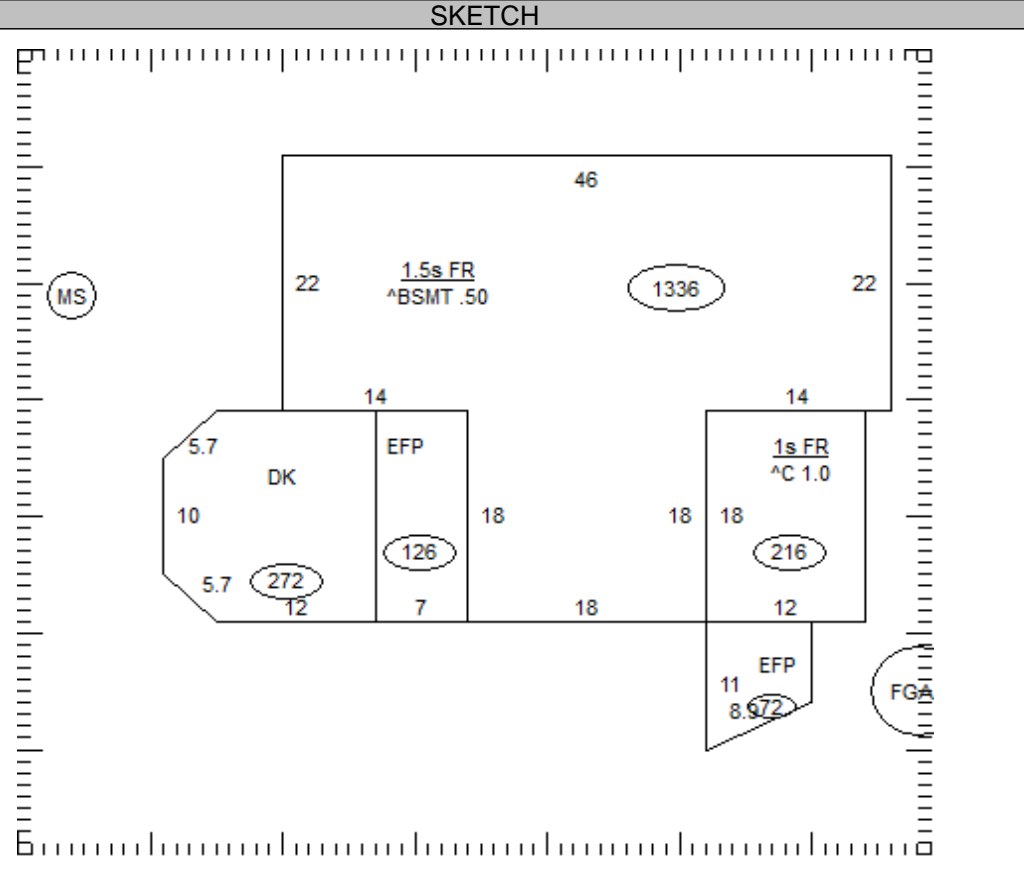

OCCUPANCY	ST.HT	SIZE	AREA	GRADE	PRICE	AGE	REMD	CND	UNADJ VAL	PHYS	PHYS VAL	FUNC	TRUE VAL
DWELLING		SK											
1													
2													
3													
4													
5													
6													
7													
8													
9													
10													
11													

20-034500.0100

TOTAL 0

COMMENTS