



**OCCUPANCY**  
 SF  DU  TR  
 CONVERSION  
**BUILDING TYPE**  
 MOBILE HOME  
 BI/TR LEVEL  
 MOD/MAN

**EXTERIOR**  
 WOOD  
 STUCCO  
 ALM/VYNL  
 CONC BLK  
 METAL  
 BRICK  
 STONE

**ROOFING**  
 METAL  
 SLT/TLE  
 SHINGLES  
 SHAKES  
 COMPOSITE

**ROOF TYPE**  
 GABLE  
 HIP  
 GAMBREL  
 MANSARD  
 FLAT

**FLOORS** B 1 2 3 U  
 CONCRETE       
 WOOD       
 TILE/COMPO       
 CARPET

**INT. FINISH** B 1 2 3 U  
 PLASTER/DW       
 PANELING       
 UNFINISHED

**ACCOMMODATIONS**  
 # OF ROOMS 6 2  
 BEDROOMS 3  
 FIREPLACES  
 HEAT & AC B 1 2 3 U

NO HEAT       
 CTRL HEAT       
 HW/STEAM       
 ELECTRIC       
 HEAT PUMP       
 FLR/WALL       
 STVE/SPCE       
 GEOTHERMAL       
 OUTSIDE       
 CTRL A/C       
 PLUMBING BASE   
 X FULL BATH  
 X HALF BATH  
 X FIXTURES

FLOOR	AREA	CONST	VALUE
1	1538	FR	205,520
+	0	FR	19,440
BSMT	769		11,000
<b>SUBTOTAL</b>			235,960
MULTI-FAMILY #	0		0
BUILDING TYPE	100%		0
BSMT FINISH	0 S.F.		0
FIREPLACE #	0		0
HEATING	0 S.F.		0
AIR COND	1,538 S.F.		2,540
PLUMBING #	0		0
GARAGES & CARPORTS			0
EXTRA FEATURES			10,600
<b>SUBTOTAL</b>			249,100
GRADE FACTOR			95 %
<b>UNADJUSTED VALUE</b>			236,650
<b>FACTOR</b>			100 %

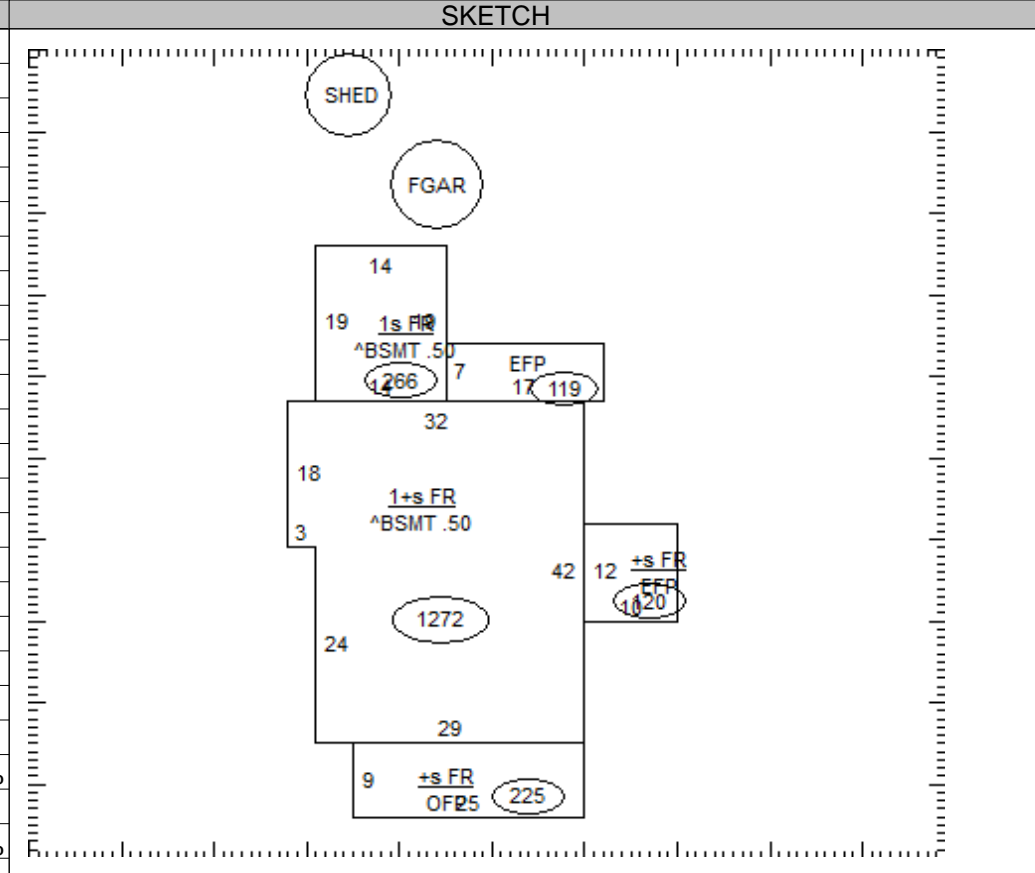

OCCUPANCY	ST.HT	SIZE	AREA	GRADE	PRICE	AGE	REMD	CND	UNADJ VAL	PHYS	PHYS VAL	FUNC	TRUE VAL
DWELLING	1+	SK	1,538	C-		1903		A	236,650	45	130,160		123,700
1 Gar - Frame		24x34	816	C	23.70	1973		A	19,340	80	3,870		3,900
2 Shed		10x15	150	C		2019		A		4			0
3													
4													
5													
6													
7													
8													
9													
10													
11													

17-041500.0000 TOTAL 127,600

**COMMENTS**

Dwelling has an Economic Factor of 95%

Property Class: 510  
Neighborhood  
001703-TM50  
Map: 04B  
Block:  
Card: 191  
Bk: Pg:

17-041500.0000

**GRUSS NATHAN M & ASHLEY M**  
GRUSS NATHAN M & ASHLEY M  
202 W CALDWELL ST  
FORT RECOVERY, OH 45846

**LEGAL INFORMATION**  
GEO W KRENNING ADDITION

LOT#: 6

OWNERSHIP	ADDRESS	CITY	STATE	ZIP	DATE	AMOUNT	DEED:CONV#	JS	VALID
1	FULLENKAMP R ELIZABETH	202 W CALDWELL ST PO	FT RECOVERY	OH 45846-0352	09/12/1986	0	: X : 0	<input type="checkbox"/>	<input type="checkbox"/>
2						0	0	<input type="checkbox"/>	<input type="checkbox"/>
3						0	0	<input type="checkbox"/>	<input type="checkbox"/>

X:  TTO LISTER: NS DATE: 09/22/2004 TIME: 12:41:45 PM  LETTER  LETTER REC'D GIS CODE

STREET/ROAD	TOPOGRAPHY	PU-UTILITIES-PR	NEIGHBORHOOD	INFLUENCE FACTORS	PROPERTY LOCATION	
200 CALDWELL ST, FT RECOVERY	<input type="checkbox"/> PAVED <input type="checkbox"/> GRAVEL <input type="checkbox"/> DIRT <input type="checkbox"/> SIDEWALKS <input type="checkbox"/> CURBS	<input type="checkbox"/> LEVEL <input checked="" type="checkbox"/> HIGH <input type="checkbox"/> LOW <input type="checkbox"/> ROLLING <input type="checkbox"/> STANDARD	<input type="checkbox"/> WATER <input type="checkbox"/> SEWER <input type="checkbox"/> GAS <input type="checkbox"/> ELECTRIC <input checked="" type="checkbox"/> STANDARD	<input type="checkbox"/> IMPROVING <input checked="" type="checkbox"/> STATIC <input type="checkbox"/> DECLINING <input type="checkbox"/> OLD <input type="checkbox"/> STANDARD	<input type="checkbox"/> A. NO ROAD <input type="checkbox"/> B. TOPGRHY <input type="checkbox"/> C. Ex Front <input type="checkbox"/> D. QUANTITY <input type="checkbox"/> E. SZ/SHAPE	<input type="checkbox"/> F. RESTRICT <input type="checkbox"/> G. WOOD LT <input type="checkbox"/> H. VACANCY <input type="checkbox"/> I. WATER FRONT <input type="checkbox"/> J. OTHER/CDU

PROPERTY LOCATION  
200 CALDWELL ST, FT RECOVERY  
COMMENT

LAND COMPUTATIONS							
LAND TYPE	SIZE	M	RATE	C	INF	M	VALUE C
TOTAL						21,300	0

**VALUATION SUMMARY**

VALUE YEAR	REASON FOR CHANGE	APPRaised VALUE	LAND IMPR TOTAL	ASSESSED VALUE	LAND IMPR TOTAL

OCCUPANCY		EXTERIOR		FLOOR	AREA	CONST	VALUE
<input type="checkbox"/> SF	<input type="checkbox"/> DU	<input type="checkbox"/> TR	<input type="checkbox"/> WOOD				
<input type="checkbox"/> CONVERSION			<input type="checkbox"/> STUCCO				
BUILDING TYPE			<input type="checkbox"/> ALM/VYNL				
<input type="checkbox"/> MOBILE HOME			<input type="checkbox"/> CONC BLK				
<input type="checkbox"/> BI/TR LEVEL			<input type="checkbox"/> METAL				
<input type="checkbox"/> MOD/MAN			<input type="checkbox"/> BRICK				
<input type="checkbox"/>			<input type="checkbox"/> STONE				

ROOFING		ROOF TYPE	
<input type="checkbox"/> METAL	<input type="checkbox"/> GABLE		
<input type="checkbox"/> SLT/TLE	<input type="checkbox"/> HIP		
<input type="checkbox"/> SHINGLES	<input type="checkbox"/> GAMBREL		
<input type="checkbox"/> SHAKES	<input type="checkbox"/> MANSARD		
<input type="checkbox"/> COMPOSITE	<input type="checkbox"/> FLAT		

FLOORS		B	1	2	3	U	SUBTOTAL	0
CONCRETE	<input type="checkbox"/>	<input type="checkbox"/>	<input type="checkbox"/>	<input type="checkbox"/>	<input type="checkbox"/>	<input type="checkbox"/>	MULTI-FAMILY #	0
WOOD	<input type="checkbox"/>	<input type="checkbox"/>	<input type="checkbox"/>	<input type="checkbox"/>	<input type="checkbox"/>	<input type="checkbox"/>	BUILDING TYPE	000%
TILE/COMPO	<input type="checkbox"/>	<input type="checkbox"/>	<input type="checkbox"/>	<input type="checkbox"/>	<input type="checkbox"/>	<input type="checkbox"/>	BSMT FINISH	0 S.F.
CARPET	<input type="checkbox"/>	<input type="checkbox"/>	<input type="checkbox"/>	<input type="checkbox"/>	<input type="checkbox"/>	<input type="checkbox"/>	FIREPLACE #	0
INT. FINISH		B	1	2	3	U	HEATING	0 S.F.
PLASTER/DW	<input type="checkbox"/>	<input type="checkbox"/>	<input type="checkbox"/>	<input type="checkbox"/>	<input type="checkbox"/>	<input type="checkbox"/>	AIR COND	0 S.F.
PANELING	<input type="checkbox"/>	<input type="checkbox"/>	<input type="checkbox"/>	<input type="checkbox"/>	<input type="checkbox"/>	<input type="checkbox"/>	PLUMBING #	0
UNFINISHED	<input type="checkbox"/>	<input type="checkbox"/>	<input type="checkbox"/>	<input type="checkbox"/>	<input type="checkbox"/>	<input type="checkbox"/>	GARAGES & CARPORTS	0
ACCOMMODATIONS							SUBTOTAL	0
# OF ROOMS							GRADE FACTOR	%
BEDROOMS							UNADJUSTED VALUE	0
FIREPLACES							FACTOR	%
HEAT & AC		B	1	2	3	U		
NO HEAT	<input type="checkbox"/>	<input type="checkbox"/>	<input type="checkbox"/>	<input type="checkbox"/>	<input type="checkbox"/>	<input type="checkbox"/>		
CTRL HEAT	<input type="checkbox"/>	<input type="checkbox"/>	<input type="checkbox"/>	<input type="checkbox"/>	<input type="checkbox"/>	<input type="checkbox"/>		
HW/STEAM	<input type="checkbox"/>	<input type="checkbox"/>	<input type="checkbox"/>	<input type="checkbox"/>	<input type="checkbox"/>	<input type="checkbox"/>		
ELECTRIC	<input type="checkbox"/>	<input type="checkbox"/>	<input type="checkbox"/>	<input type="checkbox"/>	<input type="checkbox"/>	<input type="checkbox"/>		
HEAT PUMP	<input type="checkbox"/>	<input type="checkbox"/>	<input type="checkbox"/>	<input type="checkbox"/>	<input type="checkbox"/>	<input type="checkbox"/>		
FLR/WALL	<input type="checkbox"/>	<input type="checkbox"/>	<input type="checkbox"/>	<input type="checkbox"/>	<input type="checkbox"/>	<input type="checkbox"/>		
STVE/SPCE	<input type="checkbox"/>	<input type="checkbox"/>	<input type="checkbox"/>	<input type="checkbox"/>	<input type="checkbox"/>	<input type="checkbox"/>		
GEO THERMAL	<input type="checkbox"/>	<input type="checkbox"/>	<input type="checkbox"/>	<input type="checkbox"/>	<input type="checkbox"/>	<input type="checkbox"/>		
OUTSIDE	<input type="checkbox"/>	<input type="checkbox"/>	<input type="checkbox"/>	<input type="checkbox"/>	<input type="checkbox"/>	<input type="checkbox"/>		
CTRL A/C	<input type="checkbox"/>	<input type="checkbox"/>	<input type="checkbox"/>	<input type="checkbox"/>	<input type="checkbox"/>	<input type="checkbox"/>		
PLUMBING							BASE	<input type="checkbox"/>
X FULL BATH								
X HALF BATH								
X FIXTURES								

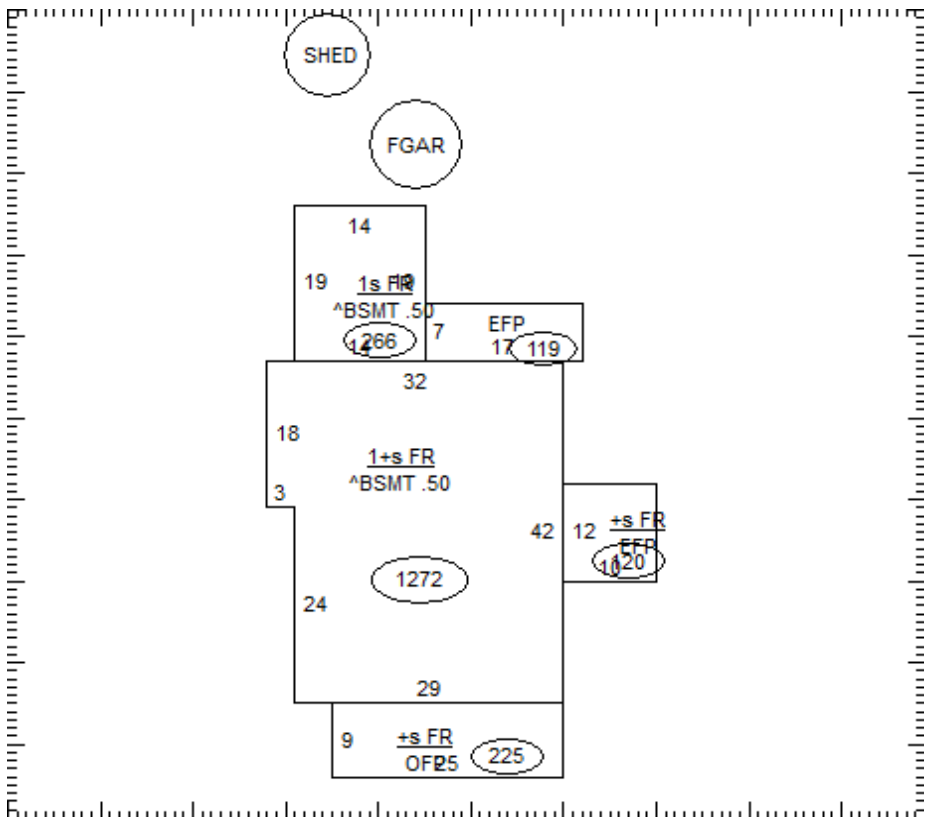

OCCUPANCY	ST.HT	SIZE	AREA	GRADE	PRICE	AGE	REMD	CND	UNADJ VAL	PHYS	PHYS VAL	FUNC	TRUE VAL
DWELLING		SK											
1													
2													
3													
4													
5													
6													
7													
8													
9													
10													
11													

17-041500.0000

TOTAL 0

COMMENTS