

GIBSON TWP-FT RECOVERY CORP / FT RECOVERY SD
13-09-377-004

Property Class: 510

Neighborhood
001701-TM50

Map: 04B

Block:

Card: 16

Bk: Pg:

17-021900.0000

ROESSNER SHAWN K & JACLYN M
ROESSNER SHAWN K & JACLYN M
206 E BOUNDARY ST
FORT RECOVERY, OH 45846

LEGAL INFORMATION
LOT 45 E END & 48 E END
OLD PLAT
LOT#: 00045

	OWNERSHIP	ADDRESS	CITY	STATE	ZIP	DATE	AMOUNT	DEED:CONV#	JS	VALID
1	ROESSNER SHAWN K &	206 E BOUNDARY ST	FORT RECOVERY	OH	45846	05/24/2019	85,000	WDC : 346	<input type="checkbox"/>	<input checked="" type="checkbox"/>
2	RIUTTA GERALD F	206 E BOUNDARY ST PO	FT RECOVERY	OH	45846	07/22/1997	64,900	: A : 0	<input type="checkbox"/>	<input checked="" type="checkbox"/>
3							0	0	<input type="checkbox"/>	<input type="checkbox"/>

X: TTO LISTER: TK DATE: 07/03/2023 TIME: 12:00:00 AM LETTER LETTER REC'D GIS CODE

STREET/ROAD	TOPOGRAPHY	PU-UTILITIES-PR	NEIGHBORHOOD	INFLUENCE FACTORS				PROPERTY LOCATION
<input checked="" type="checkbox"/> PAVED	<input checked="" type="checkbox"/> LEVEL	<input checked="" type="checkbox"/> WATER <input type="checkbox"/>	<input type="checkbox"/> IMPROVING	<input type="checkbox"/> A. NO ROAD	<input type="checkbox"/> F. RESTRICT	206 E BOUNDARY ST, FT RECOVERY		
<input type="checkbox"/> GRAVEL	<input type="checkbox"/> HIGH	<input checked="" type="checkbox"/> SEWER <input type="checkbox"/>	<input checked="" type="checkbox"/> STATIC	<input type="checkbox"/> B. TOPGRHY	<input type="checkbox"/> G. WOOD LT	COMMENT		
<input type="checkbox"/> DIRT	<input type="checkbox"/> LOW	<input type="checkbox"/> GAS <input type="checkbox"/>	<input type="checkbox"/> DECLINING	<input type="checkbox"/> C. Ex Front	<input type="checkbox"/> H. VACANCY	TY2022:Net Gen=\$991.70, Other		
<input checked="" type="checkbox"/> SIDEWALKS	<input type="checkbox"/> ROLLING	<input checked="" type="checkbox"/> ELECTRIC <input type="checkbox"/>	<input type="checkbox"/> OLD	<input type="checkbox"/> D. QUANTITY	<input type="checkbox"/> I. WATER FRONT	Assessment=\$2.00		
<input type="checkbox"/> CURBS	<input type="checkbox"/> STANDARD	<input type="checkbox"/> STANDARD	<input type="checkbox"/> STANDARD	<input type="checkbox"/> E. SZ/SHAPE	<input type="checkbox"/> J. OTHER/CDU	DE23 RMV OLD GAR, ADD NEW DET GAR		

LAND COMPUTATIONS

LAND TYPE	SIZE	M	RATE	C	INF	M	VALUE	C
F:Front	F60 D123	ST280	DP90	ADJ252			15,100	0
					TOTAL		15,100	0

VALUATION SUMMARY

VALUE YEAR	2023	2020	2017				
REASON FOR CHANGE	NC	RAPP	RAPP				
APPRAISED VALUE	LAND 15,100	11,500	9,500				
	IMPR 110,000	63,300	55,800				
	TOTAL 125,100	74,800	65,300				
ASSESSED VALUE	LAND 5,290	4,030	3,330				
	IMPR 38,500	22,160	19,530				
	TOTAL 43,790	26,190	22,860				

OCCUPANCY		EXTERIOR		FLOOR	AREA	CONST	VALUE
<input checked="" type="checkbox"/> SF	<input type="checkbox"/> DU	<input type="checkbox"/> TR	<input checked="" type="checkbox"/> WOOD	1	989	FR	159,510
<input type="checkbox"/> CONVERSION	<input type="checkbox"/> STUCCO	<input type="checkbox"/> ALM/VYNL	<input type="checkbox"/> CONC BLK	.25	245	FR	36,030
BUILDING TYPE							
<input type="checkbox"/> MOBILE HOME	<input type="checkbox"/> METAL	<input type="checkbox"/> BRICK	<input type="checkbox"/> STONE				
<input type="checkbox"/> BI/TR LEVEL	<input type="checkbox"/> SHINGLES	<input type="checkbox"/> SHAKES	<input type="checkbox"/> COMPOSITE				
<input type="checkbox"/> MOD/MAN	<input type="checkbox"/> GABLE	<input type="checkbox"/> HIP	<input type="checkbox"/> GAMBREL				
<input type="checkbox"/>	<input type="checkbox"/> MANSARD	<input type="checkbox"/> FLAT					
ROOFING		ROOF TYPE					
<input type="checkbox"/> METAL	<input checked="" type="checkbox"/> GABLE	<input type="checkbox"/> HIP	<input type="checkbox"/> GAMBREL				
<input type="checkbox"/> SLT/TLE	<input type="checkbox"/> SHINGLES	<input type="checkbox"/> SHAKES	<input type="checkbox"/> COMPOSITE				
<input type="checkbox"/>	<input type="checkbox"/> MANSARD	<input type="checkbox"/> FLAT					
FLOORS		B	1	2	3	U	
CONCRETE	<input checked="" type="checkbox"/>	<input type="checkbox"/>	<input type="checkbox"/>	<input type="checkbox"/>	<input type="checkbox"/>	<input type="checkbox"/>	
WOOD	<input type="checkbox"/>	<input checked="" type="checkbox"/>	<input checked="" type="checkbox"/>	<input type="checkbox"/>	<input type="checkbox"/>	<input type="checkbox"/>	
TILE/COMPO	<input type="checkbox"/>	<input type="checkbox"/>	<input type="checkbox"/>	<input type="checkbox"/>	<input type="checkbox"/>	<input type="checkbox"/>	
CARPET	<input type="checkbox"/>	<input type="checkbox"/>	<input type="checkbox"/>	<input type="checkbox"/>	<input type="checkbox"/>	<input type="checkbox"/>	
INT. FINISH		B	1	2	3	U	
PLASTER/DW	<input type="checkbox"/>	<input checked="" type="checkbox"/>	<input checked="" type="checkbox"/>	<input type="checkbox"/>	<input type="checkbox"/>	<input type="checkbox"/>	
PANELING	<input type="checkbox"/>	<input type="checkbox"/>	<input type="checkbox"/>	<input type="checkbox"/>	<input type="checkbox"/>	<input type="checkbox"/>	
UNFINISHED	<input checked="" type="checkbox"/>	<input type="checkbox"/>	<input type="checkbox"/>	<input type="checkbox"/>	<input type="checkbox"/>	<input type="checkbox"/>	
ACCOMMODATIONS							
# OF ROOMS	1	4	2				
BEDROOMS		1	1				
FIREPLACES							
HEAT & AC	B	1	2	3	U		
NO HEAT	<input type="checkbox"/>	<input checked="" type="checkbox"/>	<input checked="" type="checkbox"/>	<input type="checkbox"/>	<input type="checkbox"/>	<input type="checkbox"/>	
CTRL HEAT	<input type="checkbox"/>	<input type="checkbox"/>	<input type="checkbox"/>	<input type="checkbox"/>	<input type="checkbox"/>	<input type="checkbox"/>	
HW/STEAM	<input type="checkbox"/>	<input type="checkbox"/>	<input type="checkbox"/>	<input type="checkbox"/>	<input type="checkbox"/>	<input type="checkbox"/>	
ELECTRIC	<input type="checkbox"/>	<input type="checkbox"/>	<input type="checkbox"/>	<input type="checkbox"/>	<input type="checkbox"/>	<input type="checkbox"/>	
HEAT PUMP	<input type="checkbox"/>	<input type="checkbox"/>	<input type="checkbox"/>	<input type="checkbox"/>	<input type="checkbox"/>	<input type="checkbox"/>	
FLR/WALL	<input type="checkbox"/>	<input checked="" type="checkbox"/>	<input checked="" type="checkbox"/>	<input type="checkbox"/>	<input type="checkbox"/>	<input type="checkbox"/>	
STVE/SPCE	<input type="checkbox"/>	<input type="checkbox"/>	<input type="checkbox"/>	<input type="checkbox"/>	<input type="checkbox"/>	<input type="checkbox"/>	
GEO THERMAL	<input type="checkbox"/>	<input type="checkbox"/>	<input type="checkbox"/>	<input type="checkbox"/>	<input type="checkbox"/>	<input type="checkbox"/>	
OUTSIDE	<input type="checkbox"/>	<input type="checkbox"/>	<input type="checkbox"/>	<input type="checkbox"/>	<input type="checkbox"/>	<input type="checkbox"/>	
CTRL A/C	<input type="checkbox"/>	<input type="checkbox"/>	<input type="checkbox"/>	<input type="checkbox"/>	<input type="checkbox"/>	<input type="checkbox"/>	
PLUMBING		BASE		<input checked="" type="checkbox"/>			
X FULL BATH							
X HALF BATH							
X FIXTURES							
BSMT		490					7,010
SUBTOTAL							202,550
MULTI-FAMILY #		0					0
BUILDING TYPE		100%					0
BSMT FINISH		0 S.F.					0
FIREPLACE #		0					0
HEATING		1,225 S.F.					-4,650
AIR COND		0 S.F.					0
PLUMBING #		0					0
GARAGES & CARPORTS							0
EXTRA FEATURES							10,100
SUBTOTAL							208,000
GRADE FACTOR							100 %
UNADJUSTED VALUE							208,000
FACTOR							100 %

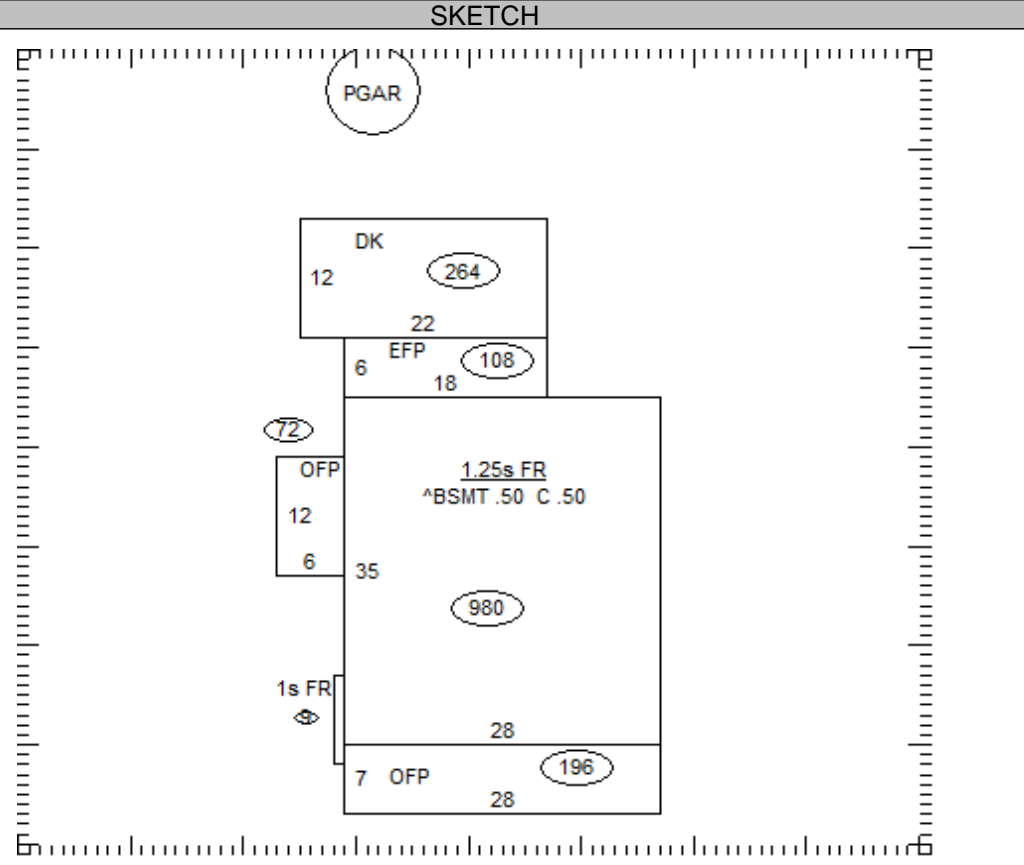

OCCUPANCY	ST.HT	SIZE	AREA	GRADE	PRICE	AGE	REMD	CND	UNADJ VAL	PHYS	PHYS VAL	FUNC	TRUE VAL
DWELLING	1.25	SK	1,234	C		1918		F	208,000	50	104,000		104,000
1 Gar - Pole		22x23	506	C	12.00	2022		A	6,070	2	5,950		6,000
2													
3													
4													
5													
6													
7													
8													
9													
10													
11													

17-021900.0000

TOTAL 110,000

COMMENTS

Dwelling has an Economic Factor of 100%