



| OCCUPANCY                              |                             | EXTERIOR                                     |                                   | FLOOR | AREA | CONST | VALUE   |
|--|-----------------------------|--|-----------------------------------|-------|------|-------|---------|
| <input checked="" type="checkbox"/> SF | <input type="checkbox"/> DU | <input type="checkbox"/> TR                  | <input type="checkbox"/> WOOD     | 1     | 1284 | FR    | 186,800 |
| <input type="checkbox"/> CONVERSION    |                             |  | <input type="checkbox"/> STUCCO   | .5    | 450  | FR    | 40,590  |
| BUILDING TYPE                          |                             | <input checked="" type="checkbox"/> ALM/VYNL |                                   |       |      |       |         |
| <input type="checkbox"/> MOBILE HOME   |                             |  | <input type="checkbox"/> CONC BLK |       |      |       |         |
| <input type="checkbox"/> BI/TR LEVEL   |                             |  | <input type="checkbox"/> METAL    |       |      |       |         |
| <input type="checkbox"/> MOD/MAN       |                             |  | <input type="checkbox"/> BRICK    |       |      |       |         |
| <input type="checkbox"/>               |                             |  | <input type="checkbox"/> STONE    |       |      |       |         |

| ROOFING                                      |  | ROOF TYPE |   |
|--|--|-----------|---|
| <input type="checkbox"/> METAL               |  |           | <input type="checkbox"/> GABLE              |
| <input type="checkbox"/> SLT/TLE             |  |           | <input type="checkbox"/> HIP                |
| <input checked="" type="checkbox"/> SHINGLES |  |           | <input checked="" type="checkbox"/> GAMBREL |
| <input type="checkbox"/> SHAKES              |  |           | <input type="checkbox"/> MANSARD            |
| <input type="checkbox"/> COMPOSITE           |  |           | <input type="checkbox"/> FLAT               |

| FLOORS         |                                     | B                                   | 1                                   | 2                        | 3                                   | U                        |
|----------------|-------------------------------------|-------------------------------------|-------------------------------------|--------------------------|-------------------------------------|--------------------------|
| CONCRETE       | <input checked="" type="checkbox"/> | <input type="checkbox"/>            | <input type="checkbox"/>            | <input type="checkbox"/> | <input type="checkbox"/>            | <input type="checkbox"/> |
| WOOD           | <input type="checkbox"/>            | <input checked="" type="checkbox"/> | <input checked="" type="checkbox"/> | <input type="checkbox"/> | <input type="checkbox"/>            | <input type="checkbox"/> |
| TILE/COMPO     | <input type="checkbox"/>            | <input checked="" type="checkbox"/> | <input checked="" type="checkbox"/> | <input type="checkbox"/> | <input type="checkbox"/>            | <input type="checkbox"/> |
| CARPET         | <input type="checkbox"/>            | <input checked="" type="checkbox"/> | <input checked="" type="checkbox"/> | <input type="checkbox"/> | <input type="checkbox"/>            | <input type="checkbox"/> |
| INT. FINISH    |                                     | B                                   | 1                                   | 2                        | 3                                   | U                        |
| PLASTER/DW     | <input type="checkbox"/>            | <input checked="" type="checkbox"/> | <input checked="" type="checkbox"/> | <input type="checkbox"/> | <input type="checkbox"/>            | <input type="checkbox"/> |
| PANELING       | <input type="checkbox"/>            | <input checked="" type="checkbox"/> | <input checked="" type="checkbox"/> | <input type="checkbox"/> | <input type="checkbox"/>            | <input type="checkbox"/> |
| UNFINISHED     | <input checked="" type="checkbox"/> | <input type="checkbox"/>            | <input type="checkbox"/>            | <input type="checkbox"/> | <input type="checkbox"/>            | <input type="checkbox"/> |
| ACCOMMODATIONS |                                     |                                     |                                     |                          |                                     |                          |
| # OF ROOMS     | 1                                   | 6                                   | 3                                   |                          |                                     |                          |
| BEDROOMS       |                                     | 1                                   | 2                                   |                          |                                     |                          |
| FIREPLACES     |                                     |                                     |                                     |                          |                                     |                          |
| HEAT & AC      |                                     | B                                   | 1                                   | 2                        | 3                                   | U                        |
| NO HEAT        | <input type="checkbox"/>            | <input type="checkbox"/>            | <input type="checkbox"/>            | <input type="checkbox"/> | <input type="checkbox"/>            | <input type="checkbox"/> |
| CTRL HEAT      | <input type="checkbox"/>            | <input checked="" type="checkbox"/> | <input checked="" type="checkbox"/> | <input type="checkbox"/> | <input type="checkbox"/>            | <input type="checkbox"/> |
| HW/STEAM       | <input type="checkbox"/>            | <input type="checkbox"/>            | <input type="checkbox"/>            | <input type="checkbox"/> | <input type="checkbox"/>            | <input type="checkbox"/> |
| ELECTRIC       | <input type="checkbox"/>            | <input type="checkbox"/>            | <input type="checkbox"/>            | <input type="checkbox"/> | <input type="checkbox"/>            | <input type="checkbox"/> |
| HEAT PUMP      | <input type="checkbox"/>            | <input type="checkbox"/>            | <input type="checkbox"/>            | <input type="checkbox"/> | <input type="checkbox"/>            | <input type="checkbox"/> |
| FLR/WALL       | <input type="checkbox"/>            | <input type="checkbox"/>            | <input type="checkbox"/>            | <input type="checkbox"/> | <input type="checkbox"/>            | <input type="checkbox"/> |
| STVE/SPCE      | <input type="checkbox"/>            | <input type="checkbox"/>            | <input type="checkbox"/>            | <input type="checkbox"/> | <input type="checkbox"/>            | <input type="checkbox"/> |
| GEOHERMAL      | <input type="checkbox"/>            | <input type="checkbox"/>            | <input type="checkbox"/>            | <input type="checkbox"/> | <input type="checkbox"/>            | <input type="checkbox"/> |
| OUTSIDE        | <input type="checkbox"/>            | <input type="checkbox"/>            | <input type="checkbox"/>            | <input type="checkbox"/> | <input type="checkbox"/>            | <input type="checkbox"/> |
| CTRL A/C       | <input type="checkbox"/>            | <input checked="" type="checkbox"/> | <input checked="" type="checkbox"/> | <input type="checkbox"/> | <input type="checkbox"/>            | <input type="checkbox"/> |
| PLUMBING       |                                     |                                     | BASE                                |                          | <input checked="" type="checkbox"/> |                          |
| X FULL BATH    |                                     | 1                                   |                                     |                          |                                     |                          |
| X HALF BATH    |                                     |                                     |                                     |                          |                                     |                          |
| X FIXTURES     |                                     |                                     |                                     |                          |                                     |                          |

|                         |            |  |         |
|-------------------------|------------|--|---------|
| BSMT                    | 182        |  | 2,600   |
| <b>SUBTOTAL</b>         |            |  | 229,990 |
| MULTI-FAMILY #          | 0          |  | 0       |
| BUILDING TYPE           | 100%       |  | 0       |
| BSMT FINISH             | 0 S.F.     |  | 0       |
| FIREPLACE #             | 0          |  | 0       |
| HEATING                 | 0 S.F.     |  | 0       |
| AIR COND                | 1,734 S.F. |  | 2,860   |
| PLUMBING #              | 3          |  | 3,630   |
| GARAGES & CARPORTS      |            |  | 0       |
| EXTRA FEATURES          |            |  | 9,700   |
| <b>SUBTOTAL</b>         |            |  | 246,180 |
| GRADE FACTOR            |            |  | 100 %   |
| <b>UNADJUSTED VALUE</b> |            |  | 246,180 |
| FACTOR                  |            |  | 100 %   |

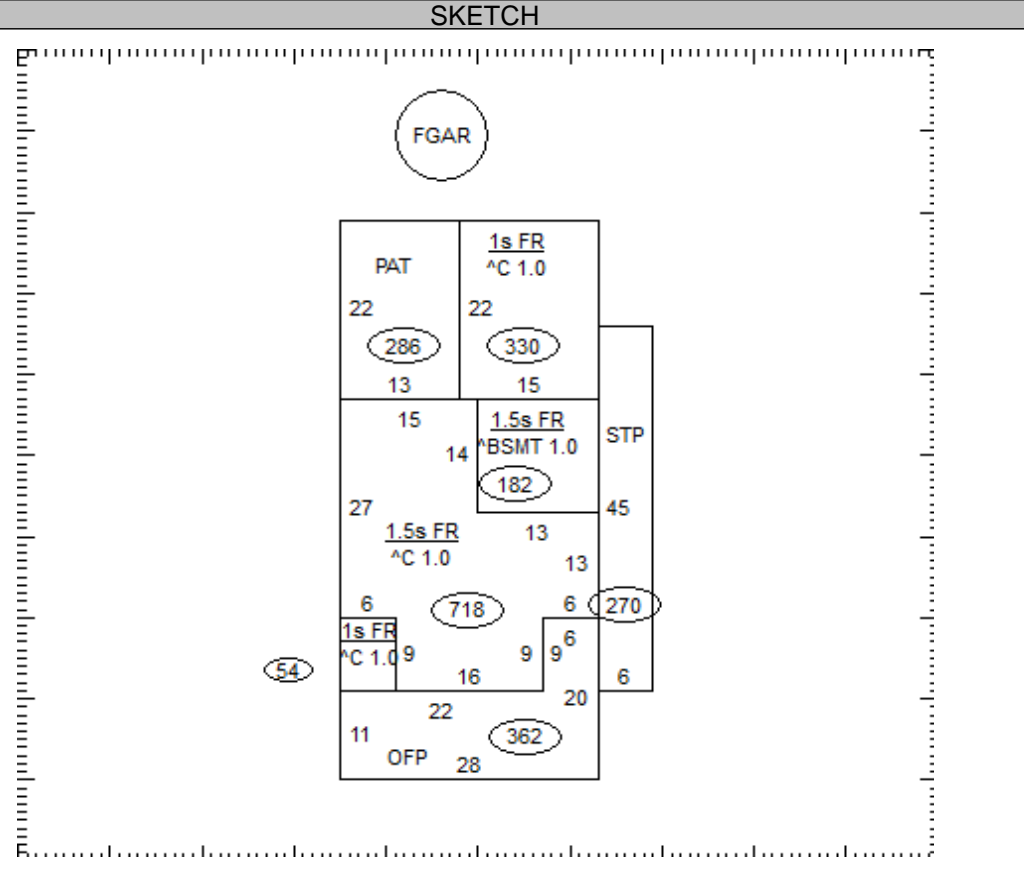

| OCCUPANCY     | ST.HT | SIZE  | AREA  | GRADE | PRICE | AGE  | REMD | CND | UNADJ VAL | PHYS | PHYS VAL | FUNC | TRUE VAL |
|---------------|-------|-------|-------|-------|-------|------|------|-----|-----------|------|----------|------|----------|
| DWELLING      | 1.5   | SK    | 1,734 | C     |       | 1898 | 1988 | A   | 246,180   | 35   | 160,020  |      | 160,000  |
| 1 Gar - Frame |       | 18x32 | 576   | C     | 23.70 | 1975 |      | F   | 13,650    | 80   | 2,730    |      | 2,700    |
| 2             |       |       |       |       |       |      |      |     |           |      |          |      |          |
| 3             |       |       |       |       |       |      |      |     |           |      |          |      |          |
| 4             |       |       |       |       |       |      |      |     |           |      |          |      |          |
| 5             |       |       |       |       |       |      |      |     |           |      |          |      |          |
| 6             |       |       |       |       |       |      |      |     |           |      |          |      |          |
| 7             |       |       |       |       |       |      |      |     |           |      |          |      |          |
| 8             |       |       |       |       |       |      |      |     |           |      |          |      |          |
| 9             |       |       |       |       |       |      |      |     |           |      |          |      |          |
| 10            |       |       |       |       |       |      |      |     |           |      |          |      |          |
| 11            |       |       |       |       |       |      |      |     |           |      |          |      |          |

17-020100.0000 TOTAL 162,700

**COMMENTS**

Dwelling has an Economic Factor of 100%

17-020100.0000

**OPEN PLACES LLC**

OPEN PLACES LLC

2410 N 87TH

SCOTTSDALE, AZ 85257

**LEGAL INFORMATION**

LOT 37 N PT OLD PLAT

LOT#: 37

| OWNERSHIP       | ADDRESS                | CITY        | STATE | ZIP   | DATE       | AMOUNT | DEED:CONV# | JS                       | VALID                    |
|-----------------|------------------------|-------------|-------|-------|------------|--------|------------|--------------------------|--------------------------|
| 1 SNYDER EDWARD | 103 MAIN ST PO BOX 138 | FT RECOVERY | OH    | 45846 | 07/26/1988 | 0      | : X : 0    | <input type="checkbox"/> | <input type="checkbox"/> |
| 2               |                        |             |       |       |            | 0      | 0          | <input type="checkbox"/> | <input type="checkbox"/> |
| 3               |                        |             |       |       |            | 0      | 0          | <input type="checkbox"/> | <input type="checkbox"/> |

X:  TTO LISTER: NS DATE: 09/16/2004 TIME: 02:09:23 PM  LETTER  LETTER REC'D GIS CODE

STREET/ROAD TOPOGRAPHY PU-UTILITIES-PR NEIGHBORHOOD INFLUENCE FACTORS PROPERTY LOCATION

|  |   |   |   |  |  |  |
|--|---|---|---|--|--|--|
| <input checked="" type="checkbox"/> PAVED<br><input type="checkbox"/> GRAVEL<br><input type="checkbox"/> DIRT<br><input checked="" type="checkbox"/> SIDEWALKS<br><input type="checkbox"/> CURBS | <input checked="" type="checkbox"/> LEVEL<br><input type="checkbox"/> HIGH<br><input type="checkbox"/> LOW<br><input type="checkbox"/> ROLLING<br><input type="checkbox"/> STANDARD | <input type="checkbox"/> WATER<br><input type="checkbox"/> SEWER<br><input type="checkbox"/> GAS<br><input type="checkbox"/> ELECTRIC<br><input checked="" type="checkbox"/> STANDARD | <input type="checkbox"/> IMPROVING<br><input checked="" type="checkbox"/> STATIC<br><input type="checkbox"/> DECLINING<br><input type="checkbox"/> OLD<br><input type="checkbox"/> STANDARD | <input type="checkbox"/> A. NO ROAD<br><input type="checkbox"/> B. TOPGRHY<br><input type="checkbox"/> C. Ex Front<br><input type="checkbox"/> D. QUANTITY<br><input type="checkbox"/> E. SZ/SHAPE | <input type="checkbox"/> F. RESTRICT<br><input type="checkbox"/> G. WOOD LT<br><input type="checkbox"/> H. VACANCY<br><input type="checkbox"/> I. WATER FRONT<br><input type="checkbox"/> J. OTHER/CDU | 103 S MAIN ST, FT RECOVERY<br><b>COMMENT</b> |
|--|---|---|---|--|--|--|

**LAND COMPUTATIONS**

| LAND TYPE | SIZE | M | RATE | C | INF | M      | VALUE | C |
|-----------|------|---|------|---|-----|--------|-------|---|
|           |      |   |      |   |     |        |       |   |
|           |      |   |      |   |     |        |       |   |
|           |      |   |      |   |     |        |       |   |
|           |      |   |      |   |     |        |       |   |
|           |      |   |      |   |     |        |       |   |
|           |      |   |      |   |     |        |       |   |
|           |      |   |      |   |     |        |       |   |
|           |      |   |      |   |     |        |       |   |
|           |      |   |      |   |     |        |       |   |
|           |      |   |      |   |     |        |       |   |
| TOTAL     |      |   |      |   |     | 12,100 | 0     |   |

**VALUATION SUMMARY**

|                   |       |  |  |  |  |  |  |  |
|-------------------|-------|--|--|--|--|--|--|--|
| VALUE YEAR        |       |  |  |  |  |  |  |  |
| REASON FOR CHANGE |       |  |  |  |  |  |  |  |
| APPRAISED VALUE   | LAND  |  |  |  |  |  |  |  |
|                   | IMPR  |  |  |  |  |  |  |  |
|                   | TOTAL |  |  |  |  |  |  |  |
| ASSESSED VALUE    | LAND  |  |  |  |  |  |  |  |
|                   | IMPR  |  |  |  |  |  |  |  |
|                   | TOTAL |  |  |  |  |  |  |  |

| OCCUPANCY   | EXTERIOR                          | FLOOR | AREA | CONST | VALUE |
|---|-----------------------------------|-------|------|-------|-------|
| <input type="checkbox"/> SF <input type="checkbox"/> DU <input type="checkbox"/> TR | <input type="checkbox"/> WOOD     |       |      |       |       |
| <input type="checkbox"/> CONVERSION   | <input type="checkbox"/> STUCCO   |       |      |       |       |
| <b>BUILDING TYPE</b>  | <input type="checkbox"/> ALM/VYNL |       |      |       |       |
| <input type="checkbox"/> MOBILE HOME  | <input type="checkbox"/> CONC BLK |       |      |       |       |
| <input type="checkbox"/> BI/TR LEVEL  | <input type="checkbox"/> METAL    |       |      |       |       |
| <input type="checkbox"/> MOD/MAN  | <input type="checkbox"/> BRICK    |       |      |       |       |
| <input type="checkbox"/>  | <input type="checkbox"/> STONE    |       |      |       |       |

| ROOFING                            | ROOF TYPE                        |
|------------------------------------|----------------------------------|
| <input type="checkbox"/> METAL     | <input type="checkbox"/> GABLE   |
| <input type="checkbox"/> SLT/TLE   | <input type="checkbox"/> HIP     |
| <input type="checkbox"/> SHINGLES  | <input type="checkbox"/> GAMBREL |
| <input type="checkbox"/> SHAKES    | <input type="checkbox"/> MANSARD |
| <input type="checkbox"/> COMPOSITE | <input type="checkbox"/> FLAT    |

| FLOORS         | B                             | 1                        | 2                        | 3                        | U                        |
|----------------|-------------------------------|--------------------------|--------------------------|--------------------------|--------------------------|
| CONCRETE       | <input type="checkbox"/>      | <input type="checkbox"/> | <input type="checkbox"/> | <input type="checkbox"/> | <input type="checkbox"/> |
| WOOD           | <input type="checkbox"/>      | <input type="checkbox"/> | <input type="checkbox"/> | <input type="checkbox"/> | <input type="checkbox"/> |
| TILE/COMPO     | <input type="checkbox"/>      | <input type="checkbox"/> | <input type="checkbox"/> | <input type="checkbox"/> | <input type="checkbox"/> |
| CARPET         | <input type="checkbox"/>      | <input type="checkbox"/> | <input type="checkbox"/> | <input type="checkbox"/> | <input type="checkbox"/> |
| INT. FINISH    | B                             | 1                        | 2                        | 3                        | U                        |
| PLASTER/DW     | <input type="checkbox"/>      | <input type="checkbox"/> | <input type="checkbox"/> | <input type="checkbox"/> | <input type="checkbox"/> |
| PANELING       | <input type="checkbox"/>      | <input type="checkbox"/> | <input type="checkbox"/> | <input type="checkbox"/> | <input type="checkbox"/> |
| UNFINISHED     | <input type="checkbox"/>      | <input type="checkbox"/> | <input type="checkbox"/> | <input type="checkbox"/> | <input type="checkbox"/> |
| ACCOMMODATIONS |                               |                          |                          |                          |                          |
| # OF ROOMS     |                               |                          |                          |                          |                          |
| BEDROOMS       |                               |                          |                          |                          |                          |
| FIREPLACES     |                               |                          |                          |                          |                          |
| HEAT & AC      | B                             | 1                        | 2                        | 3                        | U                        |
| NO HEAT        | <input type="checkbox"/>      | <input type="checkbox"/> | <input type="checkbox"/> | <input type="checkbox"/> | <input type="checkbox"/> |
| CTRL HEAT      | <input type="checkbox"/>      | <input type="checkbox"/> | <input type="checkbox"/> | <input type="checkbox"/> | <input type="checkbox"/> |
| HW/STEAM       | <input type="checkbox"/>      | <input type="checkbox"/> | <input type="checkbox"/> | <input type="checkbox"/> | <input type="checkbox"/> |
| ELECTRIC       | <input type="checkbox"/>      | <input type="checkbox"/> | <input type="checkbox"/> | <input type="checkbox"/> | <input type="checkbox"/> |
| HEAT PUMP      | <input type="checkbox"/>      | <input type="checkbox"/> | <input type="checkbox"/> | <input type="checkbox"/> | <input type="checkbox"/> |
| FLR/WALL       | <input type="checkbox"/>      | <input type="checkbox"/> | <input type="checkbox"/> | <input type="checkbox"/> | <input type="checkbox"/> |
| STVE/SPCE      | <input type="checkbox"/>      | <input type="checkbox"/> | <input type="checkbox"/> | <input type="checkbox"/> | <input type="checkbox"/> |
| GEOHERMAL      | <input type="checkbox"/>      | <input type="checkbox"/> | <input type="checkbox"/> | <input type="checkbox"/> | <input type="checkbox"/> |
| OUTSIDE        | <input type="checkbox"/>      | <input type="checkbox"/> | <input type="checkbox"/> | <input type="checkbox"/> | <input type="checkbox"/> |
| CTRL A/C       | <input type="checkbox"/>      | <input type="checkbox"/> | <input type="checkbox"/> | <input type="checkbox"/> | <input type="checkbox"/> |
| PLUMBING       | BASE <input type="checkbox"/> |                          |                          |                          |                          |
| X FULL BATH    |                               |                          |                          |                          |                          |
| X HALF BATH    |                               |                          |                          |                          |                          |
| X FIXTURES     |                               |                          |                          |                          |                          |

|                         |        |   |
|-------------------------|--------|---|
| <b>SUBTOTAL</b>         |        | 0 |
| MULTI-FAMILY #          | 0      | 0 |
| BUILDING TYPE           | 000%   | 0 |
| BSMT FINISH             | 0 S.F. | 0 |
| FIREPLACE #             | 0      | 0 |
| HEATING                 | 0 S.F. | 0 |
| AIR COND                | 0 S.F. | 0 |
| PLUMBING #              | 0      | 0 |
| GARAGES & CARPORTS      |        | 0 |
| EXTRA FEATURES          |        | 0 |
| <b>SUBTOTAL</b>         |        | 0 |
| GRADE FACTOR            |        | % |
| <b>UNADJUSTED VALUE</b> |        | 0 |
| FACTOR                  |        | % |

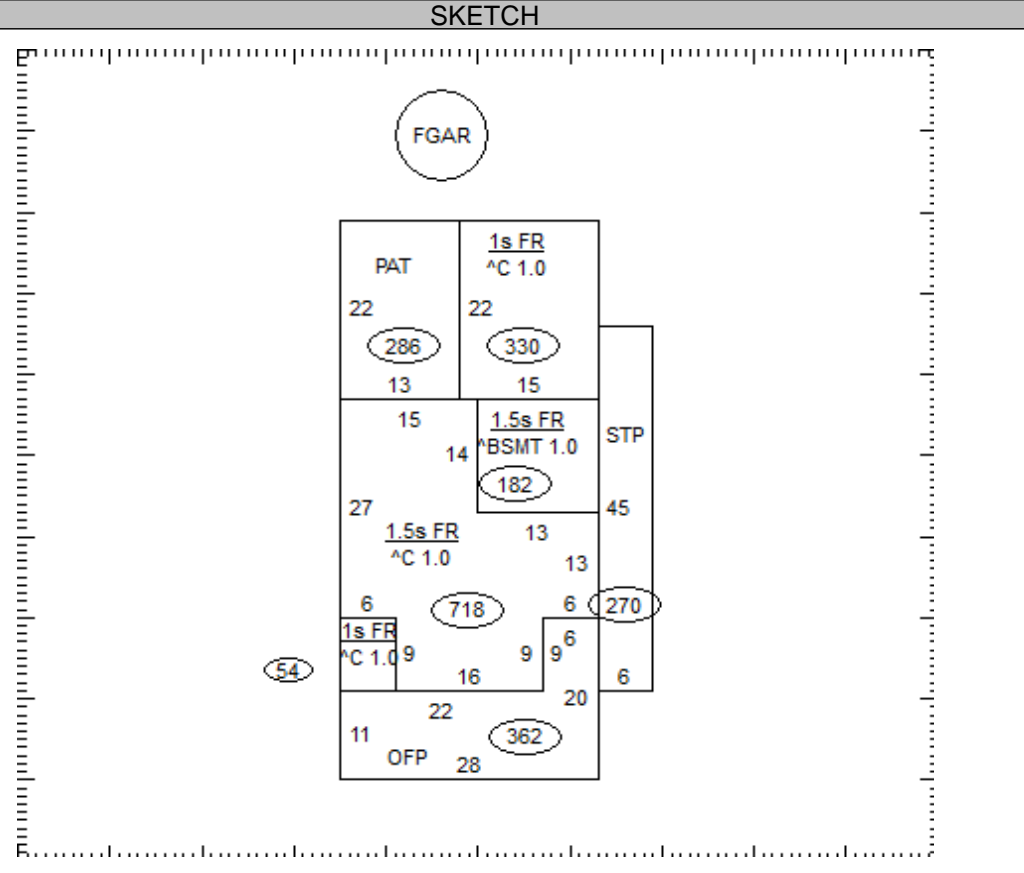

| OCCUPANCY | ST.HT | SIZE | AREA | GRADE | PRICE | AGE | REMD | CND | UNADJ VAL | PHYS | PHYS VAL | FUNC | TRUE VAL |
|-----------|-------|------|------|-------|-------|-----|------|-----|-----------|------|----------|------|----------|
| DWELLING  |       | SK   |      |       |       |     |      |     |           |      |          |      |          |
| 1         |       |      |      |       |       |     |      |     |           |      |          |      |          |
| 2         |       |      |      |       |       |     |      |     |           |      |          |      |          |
| 3         |       |      |      |       |       |     |      |     |           |      |          |      |          |
| 4         |       |      |      |       |       |     |      |     |           |      |          |      |          |
| 5         |       |      |      |       |       |     |      |     |           |      |          |      |          |
| 6         |       |      |      |       |       |     |      |     |           |      |          |      |          |
| 7         |       |      |      |       |       |     |      |     |           |      |          |      |          |
| 8         |       |      |      |       |       |     |      |     |           |      |          |      |          |
| 9         |       |      |      |       |       |     |      |     |           |      |          |      |          |
| 10        |       |      |      |       |       |     |      |     |           |      |          |      |          |
| 11        |       |      |      |       |       |     |      |     |           |      |          |      |          |

17-020100.0000 TOTAL 0

COMMENTS