

GIBSON TWP / FT RECOVERY SD

14-19-100-001

Property Class: 111

Neighborhood

009161-A100

Map: 01

Block:

Card: 15

Bk: Pg:

16-046400.0000

OSTERHOLT DAVID M & MEGAN C

OSTERHOLT DAVID M & MEGAN C

2537 STACHLER RD

FORT RECOVERY, OH 45846

LEGAL INFORMATION

PT SW NW

SEC 24 PT SE NE

RTS: 002-15-19

Acres:22.2740

QUALIFIED CREDITS: CAUV:

06335: 2018

	OWNERSHIP	ADDRESS	CITY	STATE	ZIP	DATE	AMOUNT	DEED:CONV#	JS	VALID
1	OSTERHOLT DAVID M &	2537 STACHLER RD	FORT RECOVERY	OH	45846	07/24/2017	560,000	WDC : 481	<input type="checkbox"/>	<input checked="" type="checkbox"/>
2	LINK THOMAS R & SHARON M	2537 STACHLER RD	FORT RECOVERY	OH	45846	11/04/2013	0	2:QCE : 0	<input type="checkbox"/>	<input type="checkbox"/>
3	LINK THOMAS R & SHARON M	2537 STACHLER RD	FORT RECOVERY	OH	45846	09/01/2010	0	QCE : X : 0	<input type="checkbox"/>	<input type="checkbox"/>

X:	<input type="checkbox"/> TTO	LISTER: JK	DATE: 03/19/2020	TIME: 12:00:00 AM	<input type="checkbox"/> LETTER	<input type="checkbox"/> LETTER REC'D	GIS CODE
----	------------------------------	------------	------------------	-------------------	---------------------------------	---------------------------------------	----------

STREET/ROAD	TOPOGRAPHY	PU-UTILITIES-PR	NEIGHBORHOOD	INFLUENCE FACTORS	PROPERTY LOCATION
<input checked="" type="checkbox"/> PAVED	<input type="checkbox"/> LEVEL	<input type="checkbox"/> WATER	<input type="checkbox"/> IMPROVING	<input type="checkbox"/> A. NO ROAD	2537 STACHLER RD, FT RECOVERY
<input type="checkbox"/> GRAVEL	<input type="checkbox"/> HIGH	<input type="checkbox"/> SEWER	<input type="checkbox"/> STATIC	<input type="checkbox"/> B. TOPGRHY	COMMENT
<input type="checkbox"/> DIRT	<input type="checkbox"/> LOW	<input type="checkbox"/> GAS	<input type="checkbox"/> DECLINING	<input type="checkbox"/> C. Ex Front	TY2022:Net Gen=\$3,164.14, Other
<input type="checkbox"/> SIDEWALKS	<input checked="" type="checkbox"/> ROLLING	<input type="checkbox"/> ELECTRIC	<input type="checkbox"/> OLD	<input type="checkbox"/> D. QUANTITY	Assessment=\$5.78
<input type="checkbox"/> CURBS	<input type="checkbox"/> STANDARD	<input checked="" type="checkbox"/> STANDARD	<input type="checkbox"/> STANDARD	<input type="checkbox"/> E. SZ/SHAPE	DE10 TTO; ADD FNC ON TRKY HS, ADD SHED
				<input type="checkbox"/> F. RESTRICT	DE14 SURVEYED THE LAND DE15 RMV GB
				<input type="checkbox"/> G. WOOD LT	VALUE PER ODT
				<input type="checkbox"/> H. VACANCY	DE20 TTO; ADD ADDTN & BARN
				<input type="checkbox"/> I. WATER FRONT	DE22 ADD EXTRA FIX PER DATA MAILER
				<input type="checkbox"/> J. OTHER/CDU	DE23 UPDATE OUTBLDGS; DESKTOP RVW

LAND COMPUTATIONS						
LAND TYPE	SIZE	M	RATE	C	INF	M VALUE C
CR:Crop Land TOTAL	A 21.0690	10,750	2,132		232,400	50,020
0098	A .7180	9,750	1,230		7,000	880
0024	A 11.7000	11,250	2,540		131,630	29,720
0023	A 1.0830	11,550	2,660		12,510	2,880
0084	A 2.2920	9,150	1,050		20,970	2,410
0075	A 2.5680	10,350	1,750		26,580	4,490
0087	A 2.7080	12,450	3,560		33,710	9,640
HS:Home Site	A 1.0000	26,880	26,880		26,880	26,880
RD:Road	A .2050	0	0		0	0
Total Acres: 22.2740					TOTAL	259,280 76,900

VALUATION SUMMARY									
VALUE YEAR	2023	2023	2023	2023	2022	2022	2020	2020	
REASON FOR CHANGE	CAUV	RAPP	CAUV	NC	CAUV	MISC	CAUV	RAPP	
APPRAISED	LAND	76,900	259,280	38,330	228,750	38,330	228,750	38,330	228,750
VALUE	IMPR	425,300	425,300	296,700	296,700	248,100	247,200	247,200	247,200
	TOTAL	502,200	684,580	335,030	525,450	286,430	476,850	285,530	475,950
ASSESSED	LAND	26,920	90,750	13,420	80,060	13,420	80,060	13,420	80,060
VALUE	IMPR	148,860	148,860	103,850	103,850	86,840	86,520	86,520	86,520
	TOTAL	175,780	239,610	117,270	183,910	100,260	99,940	99,940	166,580
POTENTIAL RECOUP	2022=2135.38, 2021=2142.11, 2020=2138.78: Total=6416.27								

OCCUPANCY	EXTERIOR	FLOOR	AREA	CONST	VALUE
<input checked="" type="checkbox"/> SF <input type="checkbox"/> DU <input type="checkbox"/> TR	<input type="checkbox"/> WOOD	1	1458	BRK	186,290
<input type="checkbox"/> CONVERSION	<input type="checkbox"/> STUCCO	1	480	FR	57,320
BUILDING TYPE	<input type="checkbox"/> ALM/VYNL				
<input type="checkbox"/> MOBILE HOME	<input type="checkbox"/> CONC BLK				
<input type="checkbox"/> BI/TR LEVEL	<input type="checkbox"/> METAL				
<input checked="" type="checkbox"/> MOD/MAN	<input checked="" type="checkbox"/> BRICK				
<input type="checkbox"/>	<input type="checkbox"/> STONE				

ROOFING	ROOF TYPE
<input checked="" type="checkbox"/> METAL	<input checked="" type="checkbox"/> GABLE
<input type="checkbox"/> SLT/TLE	<input type="checkbox"/> HIP
<input type="checkbox"/> SHINGLES	<input type="checkbox"/> GAMBREL
<input type="checkbox"/> SHAKES	<input type="checkbox"/> MANSARD
<input type="checkbox"/> COMPOSITE	<input type="checkbox"/> FLAT

FLOORS	B	1	2	3	U
CONCRETE	<input checked="" type="checkbox"/>	<input type="checkbox"/>	<input type="checkbox"/>	<input type="checkbox"/>	<input type="checkbox"/>
WOOD	<input type="checkbox"/>	<input type="checkbox"/>	<input type="checkbox"/>	<input type="checkbox"/>	<input type="checkbox"/>
TILE/COMPO	<input type="checkbox"/>	<input type="checkbox"/>	<input type="checkbox"/>	<input type="checkbox"/>	<input type="checkbox"/>
CARPET	<input type="checkbox"/>	<input checked="" type="checkbox"/>	<input type="checkbox"/>	<input type="checkbox"/>	<input type="checkbox"/>
INT. FINISH	B	1	2	3	U
PLASTER/DW	<input type="checkbox"/>	<input checked="" type="checkbox"/>	<input type="checkbox"/>	<input type="checkbox"/>	<input type="checkbox"/>
PANELING	<input type="checkbox"/>	<input type="checkbox"/>	<input type="checkbox"/>	<input type="checkbox"/>	<input type="checkbox"/>
UNFINISHED	<input checked="" type="checkbox"/>	<input type="checkbox"/>	<input type="checkbox"/>	<input type="checkbox"/>	<input type="checkbox"/>
ACCOMMODATIONS					
# OF ROOMS	1	9			
BEDROOMS		3			
FIREPLACES					
HEAT & AC	B	1	2	3	U
NO HEAT	<input type="checkbox"/>	<input type="checkbox"/>	<input type="checkbox"/>	<input type="checkbox"/>	<input type="checkbox"/>
CTRL HEAT	<input type="checkbox"/>	<input checked="" type="checkbox"/>	<input checked="" type="checkbox"/>	<input type="checkbox"/>	<input type="checkbox"/>
HW/STEAM	<input type="checkbox"/>	<input type="checkbox"/>	<input type="checkbox"/>	<input type="checkbox"/>	<input type="checkbox"/>
ELECTRIC	<input type="checkbox"/>	<input type="checkbox"/>	<input type="checkbox"/>	<input type="checkbox"/>	<input type="checkbox"/>
HEAT PUMP	<input type="checkbox"/>	<input type="checkbox"/>	<input type="checkbox"/>	<input type="checkbox"/>	<input type="checkbox"/>
FLR/WALL	<input type="checkbox"/>	<input type="checkbox"/>	<input type="checkbox"/>	<input type="checkbox"/>	<input type="checkbox"/>
STVE/SPCE	<input type="checkbox"/>	<input type="checkbox"/>	<input type="checkbox"/>	<input type="checkbox"/>	<input type="checkbox"/>
GEOTHERMAL	<input type="checkbox"/>	<input type="checkbox"/>	<input type="checkbox"/>	<input type="checkbox"/>	<input type="checkbox"/>
OUTSIDE	<input type="checkbox"/>	<input type="checkbox"/>	<input type="checkbox"/>	<input type="checkbox"/>	<input type="checkbox"/>
CTRL A/C	<input type="checkbox"/>	<input checked="" type="checkbox"/>	<input checked="" type="checkbox"/>	<input type="checkbox"/>	<input type="checkbox"/>
PLUMBING					
X FULL BATH		2			
X HALF BATH					
X FIXTURES		1			

BSMT	1458		20,850
SUBTOTAL			264,460
MULTI-FAMILY #	0		0
BUILDING TYPE	100%		0
BSMT FINISH	0 S.F.		0
FIREPLACE #	0		0
HEATING	0 S.F.		0
AIR COND	1,938 S.F.		3,200
PLUMBING #	7		8,470
GARAGES & CARPORTS			26,400
EXTRA FEATURES			1,900
SUBTOTAL			304,430
GRADE FACTOR			95 %
UNADJUSTED VALUE			289,210
FACTOR			100 %

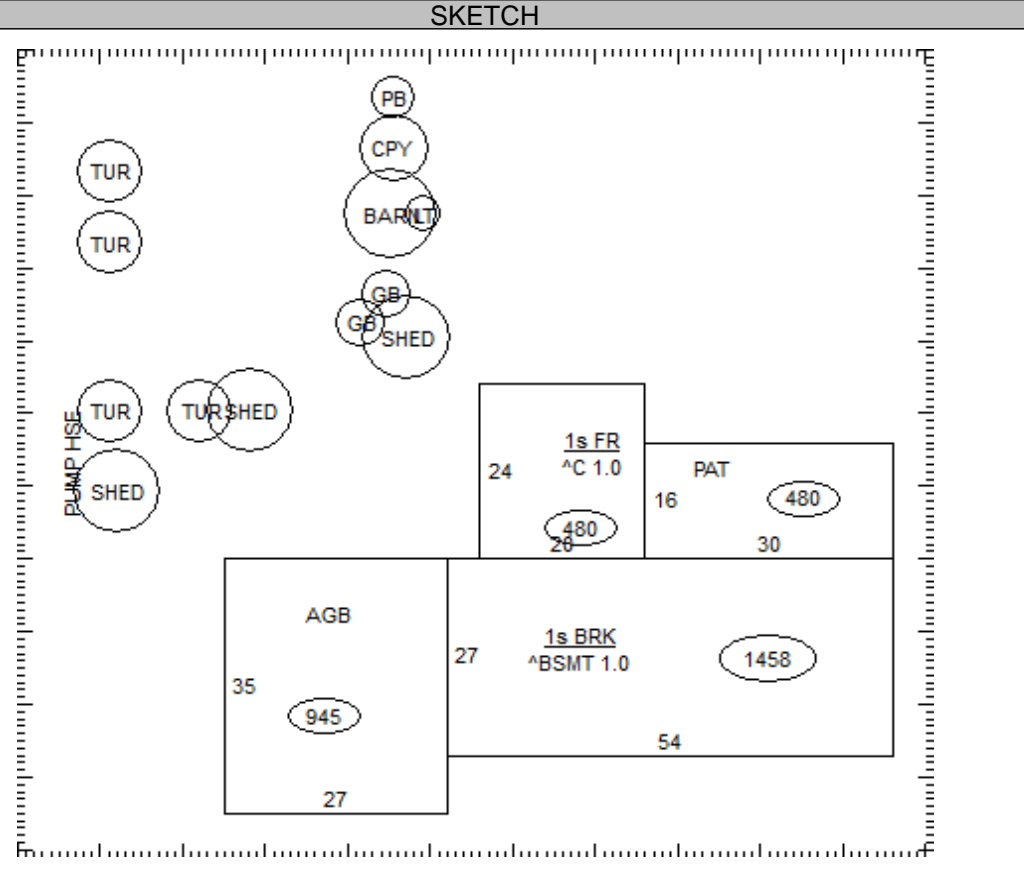

OCCUPANCY	ST.HT	SIZE	AREA	GRADE	PRICE	AGE	REMD	CND	UNADJ VAL	PHYS	PHYS VAL	FUNC	TRUE VAL
DWELLING	1	SK	1,938	C-		1993		A	289,210	24	219,800		241,800
1 Pole Bldg	14	48x96	4,608	C	10.51	2018		A	48,430	5	46,010		46,000
2 Canopy	10	60x8	480	C	7.38	2000		A	3,540	37	2,230		2,200
3 Turkey Hse	8	168x40	6,720	C	9.38	1981		A	63,030	77	14,500		14,500
4 Turkey Hse	8	160x40	6,400	C	6.00	1996		A	38,400	47	20,350		20,400
5 Grain Bin	18	18x18	324	C		1976	1990	A		80			0
6 Grain Bin	18	18x21	378	C		1980	1983	A		77			0
7 Shed	10	20x20	400	C	7.70	1981		A	3,080	77	710		700
8 Shed	10	30x32	960	C	9.98	1988		A	9,580	57	4,120		4,100
9 Turkey Hse	8	400x50	20,000	C	6.00	1979		A	120,000	77	27,600		27,600
10 Turkey Hse	8	400x50	20,000	C	6.00	1979		A	120,000	77	27,600		27,600
11 Shed		8x12	96	C		1990		G		53			0

16-046400.0000

TOTAL 384,900

COMMENTS

TRKY HSE USED AS STORAGE
 >>OB Features: 1.3 <Add Concrete Floor> 1.8 <Add Concrete Floor>
 Dwelling has an Economic Factor of 110% (Rollback Basis=\$268,680)

GIBSON TWP / FT RECOVERY SD

14-19-100-001

Property Class: 111

Neighborhood
009161-A100

Map: 01
Block:
Card: 15

Bk: Pg:

16-046400.0000

OSTERHOLT DAVID M & MEGAN C

OSTERHOLT DAVID M & MEGAN C
2537 STACHLER RD
FORT RECOVERY, OH 45846

LEGAL INFORMATION

PT SW NW
SEC 24 PT SE NE
RTS: 002-15-19
Acres:22.2740

**QUALIFIED CREDITS: CAUV:
06335: 2018**

	OWNERSHIP	ADDRESS	CITY	STATE	ZIP	DATE	AMOUNT	DEED:CONV#	JS	VALID
1	LINK THOMAS R	2537 STACHLER RD	FT RECOVERY	OH	45846		0	: 0	<input type="checkbox"/>	<input type="checkbox"/>
2							0	0	<input type="checkbox"/>	<input type="checkbox"/>
3							0	0	<input type="checkbox"/>	<input type="checkbox"/>

X: TTO LISTER: JK DATE: 03/19/2020 TIME: 12:00:00 AM LETTER LETTER REC'D GIS CODE

STREET/ROAD	TOPOGRAPHY	PU-UTILITIES-PR	NEIGHBORHOOD	INFLUENCE FACTORS				PROPERTY LOCATION
<input checked="" type="checkbox"/> PAVED	<input type="checkbox"/> LEVEL	<input type="checkbox"/> WATER	<input type="checkbox"/> IMPROVING	<input type="checkbox"/> A. NO ROAD	<input type="checkbox"/> F. RESTRICT	2537 STACHLER RD, FT RECOVERY		
<input type="checkbox"/> GRAVEL	<input type="checkbox"/> HIGH	<input type="checkbox"/> SEWER	<input type="checkbox"/> STATIC	<input type="checkbox"/> B. TOPGRHY	<input type="checkbox"/> G. WOOD LT	COMMENT		
<input type="checkbox"/> DIRT	<input type="checkbox"/> LOW	<input type="checkbox"/> GAS	<input type="checkbox"/> DECLINING	<input type="checkbox"/> C. Ex Front	<input type="checkbox"/> H. VACANCY			
<input type="checkbox"/> SIDEWALKS	<input checked="" type="checkbox"/> ROLLING	<input type="checkbox"/> ELECTRIC	<input type="checkbox"/> OLD	<input type="checkbox"/> D. QUANTITY	<input type="checkbox"/> I. WATER FRONT			
<input type="checkbox"/> CURBS	<input type="checkbox"/> STANDARD	<input checked="" type="checkbox"/> STANDARD	<input type="checkbox"/> STANDARD	<input type="checkbox"/> E. SZ/SHAPE	<input type="checkbox"/> J. OTHER/CDU			

LAND COMPUTATIONS

LAND TYPE	SIZE	M	RATE	C	INF	M	VALUE	C
Total Acres: 22.2740					TOTAL	259,280	76,900	

VALUATION SUMMARY

VALUE YEAR	2020	2020	2017	2017			
REASON FOR CHANGE	CAUV	NC	CAUV	RAPP			
APPRAISED <u>LAND</u>	56,290	229,350	56,290	229,350			
VALUE <u>IMPR</u>	252,400	252,400	226,000	226,000			
<u>TOTAL</u>	308,690	481,750	282,290	455,350			
ASSESSED <u>LAND</u>	19,700	80,270	19,700	80,270			
VALUE <u>IMPR</u>	88,340	88,340	79,100	79,100			
<u>TOTAL</u>	108,040	168,610	98,800	159,370			
POTENTIAL RECOUP	2022=2135.38, 2021=2142.11, 2020=2138.78: Total=6416.27						

OCCUPANCY		EXTERIOR		FLOOR	AREA	CONST	VALUE				SKETCH										
<input type="checkbox"/> SF	<input type="checkbox"/> DU	<input type="checkbox"/> TR	<input type="checkbox"/> WOOD																		
<input type="checkbox"/> CONVERSION			<input type="checkbox"/> STUCCO																		
BUILDING TYPE			<input type="checkbox"/> ALM/VYNL																		
<input type="checkbox"/> MOBILE HOME	<input type="checkbox"/> CONC BLK	<input type="checkbox"/> BI/TR LEVEL	<input type="checkbox"/> METAL																		
<input type="checkbox"/> MOD/MAN	<input type="checkbox"/> BRICK	<input type="checkbox"/>	<input type="checkbox"/> STONE																		
ROOFING		ROOF TYPE																			
<input type="checkbox"/> METAL	<input type="checkbox"/> GABLE	<input type="checkbox"/> SLT/TLE	<input type="checkbox"/> HIP																		
<input type="checkbox"/> SHINGLES	<input type="checkbox"/> GAMBREL	<input type="checkbox"/> SHAKES	<input type="checkbox"/> MANSARD																		
<input type="checkbox"/> COMPOSITE	<input type="checkbox"/> FLAT																				
FLOORS		B	1	2	3	U	SUBTOTAL														
CONCRETE	<input type="checkbox"/>	<input type="checkbox"/>	<input type="checkbox"/>	<input type="checkbox"/>	<input type="checkbox"/>	<input type="checkbox"/>	MULTI-FAMILY #	0			0										
WOOD	<input type="checkbox"/>	<input type="checkbox"/>	<input type="checkbox"/>	<input type="checkbox"/>	<input type="checkbox"/>	<input type="checkbox"/>	BUILDING TYPE	000%			0										
TILE/COMPO	<input type="checkbox"/>	<input type="checkbox"/>	<input type="checkbox"/>	<input type="checkbox"/>	<input type="checkbox"/>	<input type="checkbox"/>	BSMT FINISH	0 S.F.			0										
CARPET	<input type="checkbox"/>	<input type="checkbox"/>	<input type="checkbox"/>	<input type="checkbox"/>	<input type="checkbox"/>	<input type="checkbox"/>	FIREPLACE #	0			0										
INT. FINISH		B	1	2	3	U	HEATING	0 S.F.			0										
PLASTER/DW	<input type="checkbox"/>	<input type="checkbox"/>	<input type="checkbox"/>	<input type="checkbox"/>	<input type="checkbox"/>	<input type="checkbox"/>	AIR COND	0 S.F.			0										
PANELING	<input type="checkbox"/>	<input type="checkbox"/>	<input type="checkbox"/>	<input type="checkbox"/>	<input type="checkbox"/>	<input type="checkbox"/>	PLUMBING #	0			0										
UNFINISHED	<input type="checkbox"/>	<input type="checkbox"/>	<input type="checkbox"/>	<input type="checkbox"/>	<input type="checkbox"/>	<input type="checkbox"/>	GARAGES & CARPORTS				0										
ACCOMMODATIONS							SUBTOTAL														
# OF ROOMS							EXTRA FEATURES				0										
BEDROOMS							GRADE FACTOR				%										
FIREPLACES							UNADJUSTED VALUE				0										
HEAT & AC	B	1	2	3	U		FACTOR				%										
NO HEAT	<input type="checkbox"/>	<input type="checkbox"/>	<input type="checkbox"/>	<input type="checkbox"/>	<input type="checkbox"/>	<input type="checkbox"/>	OCCUPANCY														
CTRL HEAT	<input type="checkbox"/>	<input type="checkbox"/>	<input type="checkbox"/>	<input type="checkbox"/>	<input type="checkbox"/>	<input type="checkbox"/>	DWELLING	ST.HT	SIZE	AREA	GRADE	PRICE	AGE	REMD	CND	UNADJ VAL	PHYS	PHYS VAL	FUNC	TRUE VAL	
HW/STEAM	<input type="checkbox"/>	<input type="checkbox"/>	<input type="checkbox"/>	<input type="checkbox"/>	<input type="checkbox"/>	<input type="checkbox"/>	1 Barn		SK	4,136	C	12.00	2005		A	49,630	31	34,240		34,200	
ELECTRIC	<input type="checkbox"/>	<input type="checkbox"/>	<input type="checkbox"/>	<input type="checkbox"/>	<input type="checkbox"/>	<input type="checkbox"/>	2 Lean - To		20x94	1,880	C	4.80	2005		A	9,020	31	6,220		6,200	
HEAT PUMP	<input type="checkbox"/>	<input type="checkbox"/>	<input type="checkbox"/>	<input type="checkbox"/>	<input type="checkbox"/>	<input type="checkbox"/>	3														
FLR/WALL	<input type="checkbox"/>	<input type="checkbox"/>	<input type="checkbox"/>	<input type="checkbox"/>	<input type="checkbox"/>	<input type="checkbox"/>	4														
STVE/SPCE	<input type="checkbox"/>	<input type="checkbox"/>	<input type="checkbox"/>	<input type="checkbox"/>	<input type="checkbox"/>	<input type="checkbox"/>	5														
GEO THERMAL	<input type="checkbox"/>	<input type="checkbox"/>	<input type="checkbox"/>	<input type="checkbox"/>	<input type="checkbox"/>	<input type="checkbox"/>	6														
OUTSIDE	<input type="checkbox"/>	<input type="checkbox"/>	<input type="checkbox"/>	<input type="checkbox"/>	<input type="checkbox"/>	<input type="checkbox"/>	7														
CTRL A/C	<input type="checkbox"/>	<input type="checkbox"/>	<input type="checkbox"/>	<input type="checkbox"/>	<input type="checkbox"/>	<input type="checkbox"/>	8														
PLUMBING	<input type="checkbox"/>					BASE	<input type="checkbox"/>														
X FULL BATH							9														
X HALF BATH							10														
X FIXTURES							11														
																		TOTAL	40,400		
COMMENTS																					

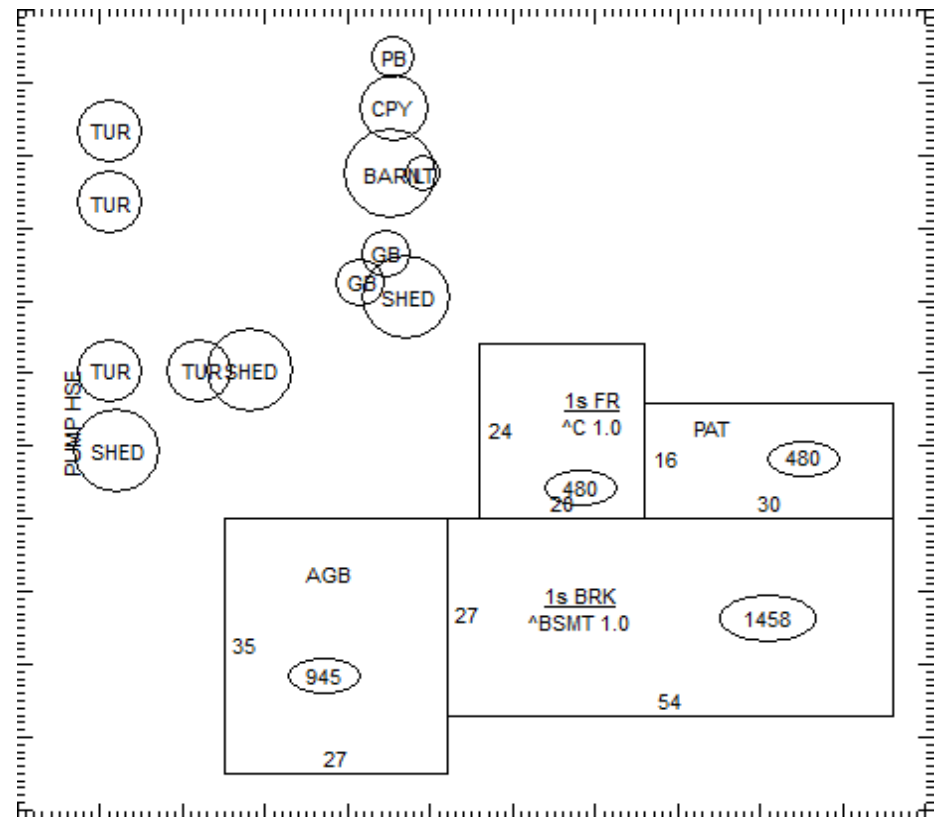

16-046400.0000

40,400

COMMENTS