

GIBSON TWP / FT RECOVERY SD

13-36-200-002



16-044500.0000

ROESSNER CHRISTOPHER J & ERICKA L
ROESSNER CHRISTOPHER J & ERICKA L
2368 WATKINS RD
FORT RECOVERY, OH 45846

LEGAL INFORMATION
PT NW NE

RTS: 001-15-36
Acres:9.0900

	OWNERSHIP	ADDRESS	CITY	STATE	ZIP	DATE	AMOUNT	DEED:CONV#	JS	VALID
1	ROESSNER CHRISTOPHER J &	2368 WATKINS RD	FORT RECOVERY	OH	45846	05/03/2019	500,000	WDC : 283	<input type="checkbox"/>	<input checked="" type="checkbox"/>
2	KNAPKE KENNETH J &	2368 WATKINS RD	FT RECOVERY	OH	45846		0	: 0	<input type="checkbox"/>	<input type="checkbox"/>
3							0	0	<input type="checkbox"/>	<input type="checkbox"/>

X: TTO LISTER: NS DATE: 10/13/2004 TIME: 12:55:39 PM LETTER LETTER REC'D GIS CODE

STREET/ROAD	TOPOGRAPHY	PU-UTILITIES-PR	NEIGHBORHOOD	INFLUENCE FACTORS	PROPERTY LOCATION
<input type="checkbox"/> PAVED <input type="checkbox"/> GRAVEL <input type="checkbox"/> DIRT <input type="checkbox"/> SIDEWALKS <input type="checkbox"/> CURBS	<input type="checkbox"/> LEVEL <input type="checkbox"/> HIGH <input type="checkbox"/> LOW <input type="checkbox"/> ROLLING <input type="checkbox"/> STANDARD	<input type="checkbox"/> WATER <input type="checkbox"/> SEWER <input type="checkbox"/> GAS <input type="checkbox"/> ELECTRIC <input checked="" type="checkbox"/> STANDARD	<input type="checkbox"/> IMPROVING <input type="checkbox"/> STATIC <input type="checkbox"/> DECLINING <input type="checkbox"/> OLD <input type="checkbox"/> STANDARD	<input type="checkbox"/> A. NO ROAD <input type="checkbox"/> B. TOPGRHY <input type="checkbox"/> C. Ex Front <input type="checkbox"/> D. QUANTITY <input type="checkbox"/> E. SZ/SHAPE	<input type="checkbox"/> F. RESTRICT <input type="checkbox"/> G. WOOD LT <input type="checkbox"/> H. VACANCY <input type="checkbox"/> I. WATER FRONT <input type="checkbox"/> J. OTHER/CDU

2368 WATKINS RD, FT RECOVERY
COMMENT
TY2022:Net Gen=\$2,165.98, Other
Assessment=\$1.08
de09 rmv patio-its a parking pad-verified aerial-data
mailer
DE17 DESKTOP RVW CHG: ADD BW & OFF

LAND COMPUTATIONS						
LAND TYPE	SIZE	M	RATE	C	INF	M VALUE C
HS:Home Site	AC:1	26880				26,900 0
SM:Small Acreage	AC:8.09	6900				55,800 0
Total Acres: 9.0900					TOTAL	82,700 0

VALUATION SUMMARY						
VALUE YEAR	2023	2023	2020	2017	2017	
REASON FOR CHANGE	RAPP	NC	RAPP	RAPP	MISC	
APPRaised	LAND 82,700	68,000	68,000	60,200	62,200	
VALUE	IMPR 171,600	131,000	128,000	107,100	117,700	
	TOTAL 254,300	199,000	196,000	167,300	179,900	
ASSESSED	LAND 28,950	23,800	23,800	21,070	21,770	
VALUE	IMPR 60,060	45,850	44,800	37,490	41,200	
	TOTAL 89,010	69,650	68,600	58,560	62,970	

OCCUPANCY	EXTERIOR	FLOOR	AREA	CONST	VALUE
<input checked="" type="checkbox"/> SF <input type="checkbox"/> DU <input type="checkbox"/> TR	<input type="checkbox"/> WOOD	1	1080	FR	168,460
<input type="checkbox"/> CONVERSION	<input type="checkbox"/> STUCCO	.5	300	FR	29,020
BUILDING TYPE	<input checked="" type="checkbox"/> ALM/VYNL				
<input type="checkbox"/> MOBILE HOME	<input type="checkbox"/> CONC BLK				
<input type="checkbox"/> BI/TR LEVEL	<input type="checkbox"/> METAL				
<input type="checkbox"/> MOD/MAN	<input type="checkbox"/> BRICK				
<input type="checkbox"/>	<input type="checkbox"/> STONE				

ROOFING	ROOF TYPE
<input type="checkbox"/> METAL	<input checked="" type="checkbox"/> GABLE
<input type="checkbox"/> SLT/TLE	<input type="checkbox"/> HIP
<input checked="" type="checkbox"/> SHINGLES	<input type="checkbox"/> GAMBREL
<input type="checkbox"/> SHAKES	<input type="checkbox"/> MANSARD
<input type="checkbox"/> COMPOSITE	<input type="checkbox"/> FLAT

FLOORS	B	1	2	3	U
CONCRETE	<input checked="" type="checkbox"/>	<input type="checkbox"/>	<input type="checkbox"/>	<input type="checkbox"/>	<input type="checkbox"/>
WOOD	<input type="checkbox"/>	<input checked="" type="checkbox"/>	<input checked="" type="checkbox"/>	<input type="checkbox"/>	<input type="checkbox"/>
TILE/COMPO	<input type="checkbox"/>	<input type="checkbox"/>	<input type="checkbox"/>	<input type="checkbox"/>	<input type="checkbox"/>
CARPET	<input type="checkbox"/>	<input checked="" type="checkbox"/>	<input checked="" type="checkbox"/>	<input type="checkbox"/>	<input type="checkbox"/>
INT. FINISH	B	1	2	3	U
PLASTER/DW	<input type="checkbox"/>	<input checked="" type="checkbox"/>	<input checked="" type="checkbox"/>	<input type="checkbox"/>	<input type="checkbox"/>
PANELING	<input type="checkbox"/>	<input type="checkbox"/>	<input type="checkbox"/>	<input type="checkbox"/>	<input type="checkbox"/>
UNFINISHED	<input checked="" type="checkbox"/>	<input type="checkbox"/>	<input type="checkbox"/>	<input type="checkbox"/>	<input type="checkbox"/>
ACCOMMODATIONS	# OF ROOMS	5	2		
BEDROOMS		1			
FIREPLACES			1		
HEAT & AC	B	1	2	3	U
NO HEAT	<input type="checkbox"/>	<input type="checkbox"/>	<input type="checkbox"/>	<input type="checkbox"/>	<input type="checkbox"/>
CTRL HEAT	<input type="checkbox"/>	<input checked="" type="checkbox"/>	<input checked="" type="checkbox"/>	<input type="checkbox"/>	<input type="checkbox"/>
HW/STEAM	<input type="checkbox"/>	<input type="checkbox"/>	<input type="checkbox"/>	<input type="checkbox"/>	<input type="checkbox"/>
ELECTRIC	<input type="checkbox"/>	<input type="checkbox"/>	<input type="checkbox"/>	<input type="checkbox"/>	<input type="checkbox"/>
HEAT PUMP	<input type="checkbox"/>	<input type="checkbox"/>	<input type="checkbox"/>	<input type="checkbox"/>	<input type="checkbox"/>
FLR/WALL	<input type="checkbox"/>	<input type="checkbox"/>	<input type="checkbox"/>	<input type="checkbox"/>	<input type="checkbox"/>
STVE/SPCE	<input type="checkbox"/>	<input type="checkbox"/>	<input type="checkbox"/>	<input type="checkbox"/>	<input type="checkbox"/>
GEOTHERMAL	<input type="checkbox"/>	<input type="checkbox"/>	<input type="checkbox"/>	<input type="checkbox"/>	<input type="checkbox"/>
OUTSIDE	<input type="checkbox"/>	<input type="checkbox"/>	<input type="checkbox"/>	<input type="checkbox"/>	<input type="checkbox"/>
CTRL A/C	<input type="checkbox"/>	<input checked="" type="checkbox"/>	<input checked="" type="checkbox"/>	<input type="checkbox"/>	<input type="checkbox"/>
PLUMBING	BASE	<input checked="" type="checkbox"/>			
X FULL BATH					
X HALF BATH					
X FIXTURES					

BSMT	450		6,440
SUBTOTAL			203,920
MULTI-FAMILY #	0		0
BUILDING TYPE	100%		0
BSMT FINISH	0 S.F.		0
FIREPLACE #	1		4,400
HEATING	0 S.F.		0
AIR COND	1,380 S.F.		2,280
PLUMBING #	0		0
GARAGES & CARPORTS			0
EXTRA FEATURES			600
SUBTOTAL			211,200
GRADE FACTOR			100 %
UNADJUSTED VALUE			211,200
FACTOR			100 %

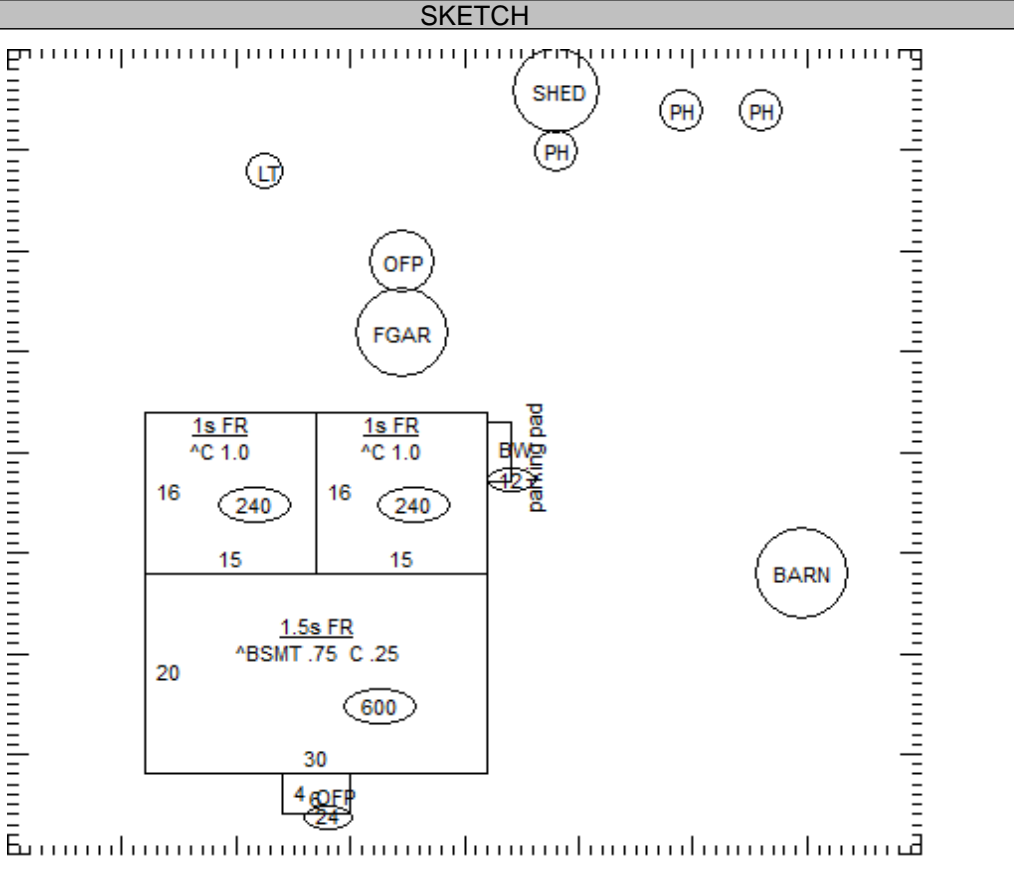

OCCUPANCY	ST.HT	SIZE	AREA	GRADE	PRICE	AGE	REMD	CND	UNADJ VAL	PHYS	PHYS VAL	FUNC	TRUE VAL
DWELLING	1.5	SK	1,380	C		1868		A	211,200	45	116,160		127,800
1 Lean - To		24x60	1,440	D	3.84	1930		P	5,530	95	280		300
2 Gar - Frame		24x24	576	C	23.70	1978		G	13,650	74	3,550		3,600
3 OFP		12x24	288	C	16.04	2000		A	4,620	37	2,910		2,900
4 Barn	14	40x50	2,000	C	12.00	1930		A	24,000	95	1,200		1,200
5 Poultry	8	40x180	7,200	C	11.25	1975		A	81,000	80	16,200		16,200
6 Poultry	8	24x80	1,920	D	9.90	1920		F	19,010	95	950	DFLT30	700
7 Poultry	8	40x180	7,200	C	11.25	1976		A	81,000	80	16,200		16,200
8 Shed		20x18	360	C	7.70	2020		A	2,770	3	2,690		2,700
9													
10													
11													

16-044500.0000 TOTAL 171,600

COMMENTS

Dwelling has an Economic Factor of 110% (Rollback Basis=\$158,300)