

14-007700.0000

**GARMAN RANDY D**

GARMAN RANDY D  
21 CANAL ST PO BOX 84  
MONTEZUMA, OH 45866

**LEGAL INFORMATION**

ORIGINAL PLAT  
LOT 33 ALSO VACATED ALLEY

OWNERSHIP	ADDRESS	CITY	STATE	ZIP	DATE	AMOUNT	DEED:CONV#	JS	VALID
1 GARMAN RANDY D	21 CANAL ST PO BOX 84	MONTEZUMA	OH	45866	09/03/2014	0	3:QCE : X : 0	<input type="checkbox"/>	<input type="checkbox"/>
2 GARMAN RANDY &	PO BOX 84	MONTEZUMA	OH	45866-0084	04/30/1992	0	: 0	<input type="checkbox"/>	<input type="checkbox"/>
3						0	0	<input type="checkbox"/>	<input type="checkbox"/>

X:  TTO LISTER: BTC DATE: 05/21/2009 TIME: 12:00:00 AM  LETTER  LETTER REC'D GIS CODE

STREET/ROAD	TOPOGRAPHY	PU-UTILITIES-PR	NEIGHBORHOOD	INFLUENCE FACTORS	PROPERTY LOCATION	
<input checked="" type="checkbox"/> PAVED <input type="checkbox"/> GRAVEL <input type="checkbox"/> DIRT <input type="checkbox"/> SIDEWALKS <input type="checkbox"/> CURBS	<input checked="" type="checkbox"/> LEVEL <input type="checkbox"/> HIGH <input type="checkbox"/> LOW <input type="checkbox"/> ROLLING <input type="checkbox"/> STANDARD	<input type="checkbox"/> WATER <input type="checkbox"/> SEWER <input checked="" type="checkbox"/> GAS <input checked="" type="checkbox"/> ELECTRIC <input type="checkbox"/> STANDARD	<input type="checkbox"/> IMPROVING <input checked="" type="checkbox"/> STATIC <input type="checkbox"/> DECLINING <input type="checkbox"/> OLD <input type="checkbox"/> STANDARD	<input type="checkbox"/> A. NO ROAD <input type="checkbox"/> B. TOPGRHY <input type="checkbox"/> C. Ex Front <input type="checkbox"/> D. QUANTITY <input type="checkbox"/> E. SZ/SHAPE	<input type="checkbox"/> F. RESTRICT <input type="checkbox"/> G. WOOD LT <input type="checkbox"/> H. VACANCY <input type="checkbox"/> I. WATER FRONT <input type="checkbox"/> J. OTHER/CDU	21 S CANAL ST, MONTEZUMA <b>COMMENT</b> TY2022:Net Gen=\$1,400.38, Other Assessment=\$44.00 DE09 NO CHG DE08 NO CHG

**LAND COMPUTATIONS**

LAND TYPE	SIZE	M	RATE	C	INF	M	VALUE	C
F:Front	F82 D130	ST190	DP93	ADJ177			14,500	0
						<b>TOTAL</b>	14,500	0

**VALUATION SUMMARY**

VALUE YEAR	2023	2020	2017
REASON FOR CHANGE	RAPP	RAPP	RAPP
APPRAISED VALUE	LAND 14,500	8,900	6,900
	IMPR 114,900	75,900	66,800
	TOTAL 129,400	84,800	73,700
ASSESSED VALUE	LAND 5,080	3,120	2,420
	IMPR 40,220	26,570	23,380
	TOTAL 45,300	29,690	25,800

<b>OCCUPANCY</b>		<b>EXTERIOR</b>		<b>FLOOR</b>	<b>AREA</b>	<b>CONST</b>	<b>VALUE</b>
<input checked="" type="checkbox"/> SF	<input type="checkbox"/> DU	<input type="checkbox"/> TR	<input type="checkbox"/> WOOD	1	1632	FR	211,330
<input type="checkbox"/> CONVERSION			<input type="checkbox"/> STUCCO				
<b>BUILDING TYPE</b>			<input checked="" type="checkbox"/> ALM/VYNL				
<input type="checkbox"/> MOBILE HOME			<input type="checkbox"/> CONC BLK				
<input type="checkbox"/> BI/TR LEVEL			<input type="checkbox"/> METAL				
<input type="checkbox"/> MOD/MAN			<input type="checkbox"/> BRICK				
<input type="checkbox"/>			<input type="checkbox"/> STONE				
<b>ROOFING</b>		<b>ROOF TYPE</b>					
<input type="checkbox"/> METAL			<input checked="" type="checkbox"/> GABLE				
<input type="checkbox"/> SLT/TLE			<input type="checkbox"/> HIP				
<input checked="" type="checkbox"/> SHINGLES			<input type="checkbox"/> GAMBREL				
<input type="checkbox"/> SHAKES			<input type="checkbox"/> MANSARD				
<input type="checkbox"/> COMPOSITE			<input type="checkbox"/> FLAT				
<b>FLOORS</b>		<b>B</b>	<b>1</b>	<b>2</b>	<b>3</b>	<b>U</b>	
CONCRETE	<input type="checkbox"/>	<input type="checkbox"/>	<input type="checkbox"/>	<input type="checkbox"/>	<input type="checkbox"/>	<input type="checkbox"/>	
WOOD	<input type="checkbox"/>	<input checked="" type="checkbox"/>	<input type="checkbox"/>	<input type="checkbox"/>	<input type="checkbox"/>	<input type="checkbox"/>	
TILE/COMPO	<input type="checkbox"/>	<input type="checkbox"/>	<input type="checkbox"/>	<input type="checkbox"/>	<input type="checkbox"/>	<input type="checkbox"/>	
CARPET	<input type="checkbox"/>	<input type="checkbox"/>	<input type="checkbox"/>	<input type="checkbox"/>	<input type="checkbox"/>	<input type="checkbox"/>	

<b>SUBTOTAL</b>			211,330
MULTI-FAMILY #	0		0
BUILDING TYPE	100%		0
BSMT FINISH	0 S.F.		0
FIREPLACE #	0		0
HEATING	0 S.F.		0
AIR COND	1,632 S.F.		2,690
PLUMBING #	0		0
GARAGES & CARPORTS			0
EXTRA FEATURES			4,800
<b>SUBTOTAL</b>			218,820
GRADE FACTOR			100 %
<b>UNADJUSTED VALUE</b>			218,820
FACTOR			100 %

<b>ACCOMMODATIONS</b>					
# OF ROOMS	6				
BEDROOMS	3				
<b>FIREPLACES</b>					
<b>HEAT &amp; AC</b>		<b>B</b>	<b>1</b>	<b>2</b>	<b>3</b>
NO HEAT	<input type="checkbox"/>	<input type="checkbox"/>	<input type="checkbox"/>	<input type="checkbox"/>	<input type="checkbox"/>
CTRL HEAT	<input type="checkbox"/>	<input checked="" type="checkbox"/>	<input type="checkbox"/>	<input type="checkbox"/>	<input type="checkbox"/>
HW/STEAM	<input type="checkbox"/>	<input type="checkbox"/>	<input type="checkbox"/>	<input type="checkbox"/>	<input type="checkbox"/>
ELECTRIC	<input type="checkbox"/>	<input type="checkbox"/>	<input type="checkbox"/>	<input type="checkbox"/>	<input type="checkbox"/>
HEAT PUMP	<input type="checkbox"/>	<input type="checkbox"/>	<input type="checkbox"/>	<input type="checkbox"/>	<input type="checkbox"/>
FLR/WALL	<input type="checkbox"/>	<input type="checkbox"/>	<input type="checkbox"/>	<input type="checkbox"/>	<input type="checkbox"/>
STVE/SPCE	<input type="checkbox"/>	<input type="checkbox"/>	<input type="checkbox"/>	<input type="checkbox"/>	<input type="checkbox"/>
GEOTHERMAL	<input type="checkbox"/>	<input type="checkbox"/>	<input type="checkbox"/>	<input type="checkbox"/>	<input type="checkbox"/>
OUTSIDE	<input type="checkbox"/>	<input type="checkbox"/>	<input type="checkbox"/>	<input type="checkbox"/>	<input type="checkbox"/>
CTRL A/C	<input type="checkbox"/>	<input checked="" type="checkbox"/>	<input type="checkbox"/>	<input type="checkbox"/>	<input type="checkbox"/>
<b>PLUMBING</b>		<b>BASE</b> <input checked="" type="checkbox"/>			
X FULL BATH					
X HALF BATH					
X FIXTURES					

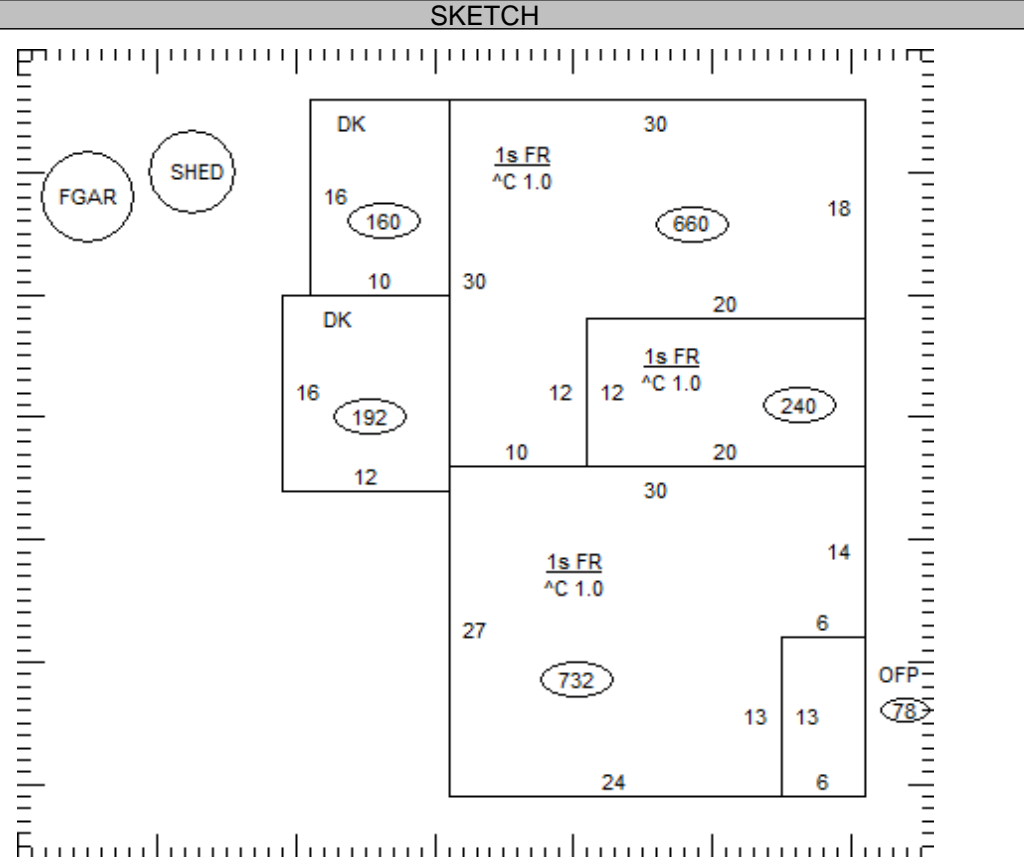

14-007700.0000											TOTAL	114,900
----------------	--	--	--	--	--	--	--	--	--	--	-------	---------

COMMENTS												
Dwelling has an Economic Factor of 95%												