

FRANKLIN TWP / CELINA SD

09-28-300-003

Property Class: 510

Neighborhood

009095-R150

Map: 04A1

Block:

Card: 124

Bk: Pg:

09-116600.0000

**PIPER ZACHARY R & ASHLEY R**

PIPER ZACHARY R & ASHLEY R

4555 CO RD 716A

CELINA, OH 45822

**LEGAL INFORMATION**

PT W 1/2 SW

RTS: 003-06-28

Acres:1.9600

	OWNERSHIP	ADDRESS	CITY	STATE	ZIP	DATE	AMOUNT	DEED:CONV#	JS	VALID
1	PIPER ZACHARY R & ASHLEY	4555 CO RD 716A	CELINA	OH	45822	03/01/2021	239,000	WDC : 145	<input type="checkbox"/>	<input checked="" type="checkbox"/>
2	REEDER JOSHUA D	4555 CO RD 716A	CELINA	OH	45822	08/21/2019	0	QCE : X : 0	<input type="checkbox"/>	<input type="checkbox"/>
3	SEIBERT KAREN E	211 NORT OAK ST	ROCKFORD	OH	45882	07/07/2017	0	AFE : X : 0	<input type="checkbox"/>	<input type="checkbox"/>

X:  TTO LISTER: DATE: 04/07/2011 TIME: 12:00:00 AM  LETTER  LETTER REC'D GIS CODE

STREET/ROAD TOPOGRAPHY PU-UTILITIES-PR NEIGHBORHOOD INFLUENCE FACTORS PROPERTY LOCATION

PAVED  LEVEL  WATER  IMPROVING  A. NO ROAD  F. RESTRICT 4555 COUNTY ROAD 716A, CELINA  
 GRAVEL  HIGH  SEWER  STATIC  B. TOPGRHY  G. WOOD LT COMMENT  
 DIRT  LOW  GAS  DECLINING  C. Ex Front  H. VACANCY TY2022:Net Gen=\$2,583.72, Other  
 SIDEWALKS  ROLLING  ELECTRIC  OLD  D. QUANTITY  I. WATER FRONT Assessment=\$0.00  
 CURBS  STANDARD  STANDARD  E. SZ/SHAPE  J. OTHER/CDU DE11 CORR STRY HGHT

**LAND COMPUTATIONS**

LAND TYPE	SIZE	M	RATE	C	INF	M	VALUE	C
HS:Home Site	AC:1	24300				24,300	0	
SM:Small Acreage	AC:0.96	8500				8,200	0	
Total Acres: 1.9600						TOTAL	32,500	0

**VALUATION SUMMARY**

VALUE YEAR	2023	2021	2020	2017	2017	2017	2017
REASON FOR CHANGE	RAPP	NC	RAPP	RAPP	MISC	MISC	MISC
APPRAISED VALUE	LAND 32,500	24,400	24,400	23,200	23,500	23,500	23,500
	IMPR 199,500	132,000	119,600	103,900	106,200	100,800	87,900
	TOTAL 232,000	156,400	144,000	127,100	129,700	124,300	111,400
ASSESSED VALUE	LAND 11,380	8,540	8,540	8,120	8,230	8,230	8,230
	IMPR 69,830	46,200	41,860	36,370	37,170	35,280	30,770
	TOTAL 81,210	54,740	50,400	44,490	45,400	43,510	39,000

<b>OCCUPANCY</b>	<b>EXTERIOR</b>	<b>FLOOR</b>	<b>AREA</b>	<b>CONST</b>	<b>VALUE</b>
<input checked="" type="checkbox"/> SF <input type="checkbox"/> DU <input type="checkbox"/> TR	<input type="checkbox"/> WOOD	1	1508	FR	201,510
<input type="checkbox"/> CONVERSION	<input type="checkbox"/> STUCCO	2ND	630	FR	40,410
<b>BUILDING TYPE</b>	<input checked="" type="checkbox"/> ALM/VYNL	+	0	FR	8,270
<input type="checkbox"/> MOBILE HOME	<input type="checkbox"/> CONC BLK				
<input type="checkbox"/> BI/TR LEVEL	<input type="checkbox"/> METAL				
<input type="checkbox"/> MOD/MAN	<input type="checkbox"/> BRICK				
<input type="checkbox"/>	<input type="checkbox"/> STONE				

<b>ROOFING</b>	<b>ROOF TYPE</b>
<input type="checkbox"/> METAL	<input checked="" type="checkbox"/> GABLE
<input type="checkbox"/> SLT/TLE	<input type="checkbox"/> HIP
<input checked="" type="checkbox"/> SHINGLES	<input type="checkbox"/> GAMBREL
<input type="checkbox"/> SHAKES	<input type="checkbox"/> MANSARD
<input type="checkbox"/> COMPOSITE	<input type="checkbox"/> FLAT

<b>FLOORS</b>	<b>B</b>	<b>1</b>	<b>2</b>	<b>3</b>	<b>U</b>
CONCRETE	<input checked="" type="checkbox"/>	<input type="checkbox"/>	<input type="checkbox"/>	<input type="checkbox"/>	<input type="checkbox"/>
WOOD	<input type="checkbox"/>	<input type="checkbox"/>	<input type="checkbox"/>	<input type="checkbox"/>	<input type="checkbox"/>
TILE/COMPO	<input type="checkbox"/>	<input checked="" type="checkbox"/>	<input type="checkbox"/>	<input type="checkbox"/>	<input type="checkbox"/>
CARPET	<input type="checkbox"/>	<input checked="" type="checkbox"/>	<input type="checkbox"/>	<input type="checkbox"/>	<input type="checkbox"/>
<b>INT. FINISH</b>	<b>B</b>	<b>1</b>	<b>2</b>	<b>3</b>	<b>U</b>
PLASTER/DW	<input type="checkbox"/>	<input checked="" type="checkbox"/>	<input type="checkbox"/>	<input type="checkbox"/>	<input type="checkbox"/>
PANELING	<input type="checkbox"/>	<input type="checkbox"/>	<input type="checkbox"/>	<input type="checkbox"/>	<input type="checkbox"/>
UNFINISHED	<input checked="" type="checkbox"/>	<input type="checkbox"/>	<input type="checkbox"/>	<input type="checkbox"/>	<input type="checkbox"/>
<b>ACCOMMODATIONS</b>					
# OF ROOMS		5			
BEDROOMS		3			
FIREPLACES					
<b>HEAT &amp; AC</b>	<b>B</b>	<b>1</b>	<b>2</b>	<b>3</b>	<b>U</b>
NO HEAT	<input type="checkbox"/>	<input type="checkbox"/>	<input type="checkbox"/>	<input type="checkbox"/>	<input type="checkbox"/>
CTRL HEAT	<input type="checkbox"/>	<input checked="" type="checkbox"/>	<input type="checkbox"/>	<input type="checkbox"/>	<input type="checkbox"/>
HW/STEAM	<input type="checkbox"/>	<input type="checkbox"/>	<input type="checkbox"/>	<input type="checkbox"/>	<input type="checkbox"/>
ELECTRIC	<input type="checkbox"/>	<input type="checkbox"/>	<input type="checkbox"/>	<input type="checkbox"/>	<input type="checkbox"/>
HEAT PUMP	<input type="checkbox"/>	<input type="checkbox"/>	<input type="checkbox"/>	<input type="checkbox"/>	<input type="checkbox"/>
FLR/WALL	<input type="checkbox"/>	<input type="checkbox"/>	<input type="checkbox"/>	<input type="checkbox"/>	<input type="checkbox"/>
STVE/SPCE	<input type="checkbox"/>	<input type="checkbox"/>	<input type="checkbox"/>	<input type="checkbox"/>	<input type="checkbox"/>
GEO THERMAL	<input type="checkbox"/>	<input type="checkbox"/>	<input type="checkbox"/>	<input type="checkbox"/>	<input type="checkbox"/>
OUTSIDE	<input type="checkbox"/>	<input type="checkbox"/>	<input type="checkbox"/>	<input type="checkbox"/>	<input type="checkbox"/>
CTRL A/C	<input type="checkbox"/>	<input type="checkbox"/>	<input type="checkbox"/>	<input type="checkbox"/>	<input type="checkbox"/>
<b>PLUMBING</b>					
X FULL BATH		1			
X HALF BATH					
X FIXTURES					

BSMT	1318		18,850
<b>SUBTOTAL</b>			269,040
MULTI-FAMILY #	0		0
BUILDING TYPE	100%		0
BSMT FINISH	0 S.F.		0
FIREPLACE #	0		0
HEATING	0 S.F.		0
AIR COND	0 S.F.		0
PLUMBING #	3		3,630
GARAGES & CARPORTS			14,200
EXTRA FEATURES			300
<b>SUBTOTAL</b>			287,170
GRADE FACTOR			105 %
<b>UNADJUSTED VALUE</b>			301,530
FACTOR			100 %

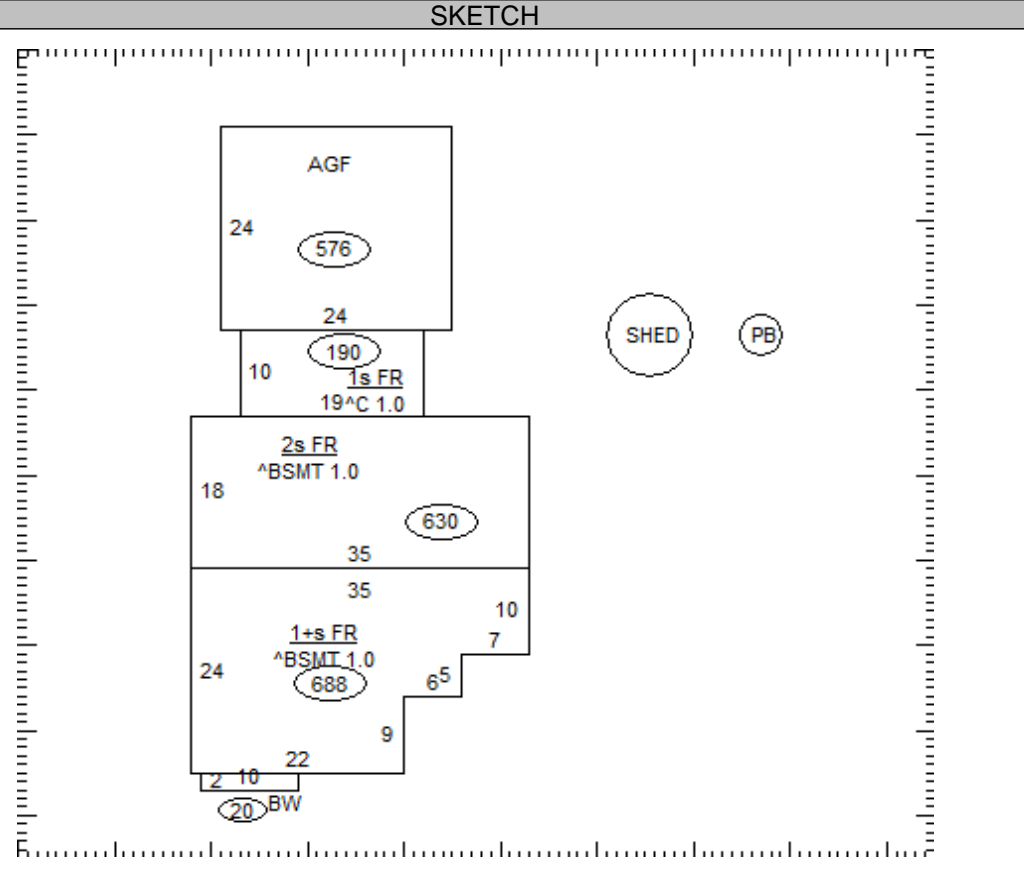

OCCUPANCY	ST.HT	SIZE	AREA	GRADE	PRICE	AGE	REMD	CND	UNADJ VAL	PHYS	PHYS VAL	FUNC	TRUE VAL
DWELLING	1.5	SK	2,138	C+		1900	1950	A	301,530	42	174,890		174,900
1 Pole Bldg	10	50x40	2,000	C	23.03	1997		A	46,060	47	24,410		24,400
2 Shed	8	18x24	432	C	7.70	1900		P	3,330	95	170		200
3													
4													
5													
6													
7													
8													
9													
10													
11													

09-116600.0000 TOTAL 199,500

**COMMENTS**

>>OB Features: 1.1 <Add Concrete Floor> <Shop/Garage Finish>  
 Dwelling has an Economic Factor of 100% (Rollback Basis=\$199,200)

FRANKLIN TWP / CELINA SD

09-28-300-003

Property Class: 510

Neighborhood

009095-R150

Map: 04A1

Block:

Card: 124

Bk: Pg:

09-116600.0000

**PIPER ZACHARY R & ASHLEY R**

PIPER ZACHARY R & ASHLEY R

4555 CO RD 716A

CELINA, OH 45822

**LEGAL INFORMATION**

PT W 1/2 SW

RTS: 003-06-28

Acres:1.9600

	OWNERSHIP	ADDRESS	CITY	STATE	ZIP	DATE	AMOUNT	DEED:CONV#	JS	VALID
1	SEIBERT LARRY D & KAREN E	4555 COUNTY ROAD 716A	CELINA	OH	45822	06/26/2014	0	QCE : X : 0	<input type="checkbox"/>	<input type="checkbox"/>
2	SEIBERT-KIRVES KAREN E	4555 COUNTY RD 716A	CELINA	OH	45822	11/23/1993	82,900	: A : 0	<input type="checkbox"/>	<input type="checkbox"/>
3							0	0	<input type="checkbox"/>	<input type="checkbox"/>

X:  TTO LISTER: DATE: 04/07/2011 TIME: 12:00:00 AM  LETTER  LETTER REC'D GIS CODE

STREET/ROAD	TOPOGRAPHY	PU-UTILITIES-PR	NEIGHBORHOOD	INFLUENCE FACTORS	PROPERTY LOCATION
<input checked="" type="checkbox"/> PAVED	<input checked="" type="checkbox"/> LEVEL	<input type="checkbox"/> WATER <input type="checkbox"/>	<input type="checkbox"/> IMPROVING	<input type="checkbox"/> A. NO ROAD <input type="checkbox"/> F. RESTRICT	4555 COUNTY ROAD 716A, CELINA COMMENT
<input type="checkbox"/> GRAVEL	<input type="checkbox"/> HIGH	<input type="checkbox"/> SEWER <input type="checkbox"/>	<input checked="" type="checkbox"/> STATIC	<input type="checkbox"/> B. TOPGRHY <input type="checkbox"/> G. WOOD LT	
<input type="checkbox"/> DIRT	<input type="checkbox"/> LOW	<input type="checkbox"/> GAS <input type="checkbox"/>	<input type="checkbox"/> DECLINING	<input type="checkbox"/> C. Ex Front <input type="checkbox"/> H. VACANCY	
<input type="checkbox"/> SIDEWALKS	<input type="checkbox"/> ROLLING	<input type="checkbox"/> ELECTRIC <input type="checkbox"/>	<input type="checkbox"/> OLD	<input type="checkbox"/> D. QUANTITY <input type="checkbox"/> I. WATER FRONT	
<input type="checkbox"/> CURBS	<input type="checkbox"/> STANDARD	<input checked="" type="checkbox"/> STANDARD	<input type="checkbox"/> STANDARD	<input type="checkbox"/> E. SZ/SHAPE <input type="checkbox"/> J. OTHER/CDU	

LAND COMPUTATIONS

LAND TYPE	SIZE	M	RATE	C	INF	M	VALUE	C
Total Acres: 1.9600					TOTAL		32,500	0

VALUATION SUMMARY

VALUE YEAR								
REASON FOR CHANGE								
APPRaised	<u>LAND</u>							
VALUE	<u>IMPR</u>							
	<u>TOTAL</u>							
ASSESSED	<u>LAND</u>							
VALUE	<u>IMPR</u>							
	<u>TOTAL</u>							

OCCUPANCY	EXTERIOR	FLOOR	AREA	CONST	VALUE
<input type="checkbox"/> SF <input type="checkbox"/> DU <input type="checkbox"/> TR	<input type="checkbox"/> WOOD				
<input type="checkbox"/> CONVERSION	<input type="checkbox"/> STUCCO				
<b>BUILDING TYPE</b>	<input type="checkbox"/> ALM/VYNL				
<input type="checkbox"/> MOBILE HOME	<input type="checkbox"/> CONC BLK				
<input type="checkbox"/> BI/TR LEVEL	<input type="checkbox"/> METAL				
<input type="checkbox"/> MOD/MAN	<input type="checkbox"/> BRICK				
<input type="checkbox"/>	<input type="checkbox"/> STONE				

ROOFING	ROOF TYPE
<input type="checkbox"/> METAL	<input type="checkbox"/> GABLE
<input type="checkbox"/> SLT/TLE	<input type="checkbox"/> HIP
<input type="checkbox"/> SHINGLES	<input type="checkbox"/> GAMBREL
<input type="checkbox"/> SHAKES	<input type="checkbox"/> MANSARD
<input type="checkbox"/> COMPOSITE	<input type="checkbox"/> FLAT

FLOORS	B	1	2	3	U
CONCRETE	<input type="checkbox"/>	<input type="checkbox"/>	<input type="checkbox"/>	<input type="checkbox"/>	<input type="checkbox"/>
WOOD	<input type="checkbox"/>	<input type="checkbox"/>	<input type="checkbox"/>	<input type="checkbox"/>	<input type="checkbox"/>
TILE/COMPO	<input type="checkbox"/>	<input type="checkbox"/>	<input type="checkbox"/>	<input type="checkbox"/>	<input type="checkbox"/>
CARPET	<input type="checkbox"/>	<input type="checkbox"/>	<input type="checkbox"/>	<input type="checkbox"/>	<input type="checkbox"/>
INT. FINISH	B	1	2	3	U
PLASTER/DW	<input type="checkbox"/>	<input type="checkbox"/>	<input type="checkbox"/>	<input type="checkbox"/>	<input type="checkbox"/>
PANELING	<input type="checkbox"/>	<input type="checkbox"/>	<input type="checkbox"/>	<input type="checkbox"/>	<input type="checkbox"/>
UNFINISHED	<input type="checkbox"/>	<input type="checkbox"/>	<input type="checkbox"/>	<input type="checkbox"/>	<input type="checkbox"/>
ACCOMMODATIONS					
# OF ROOMS					
BEDROOMS					
FIREPLACES					
HEAT & AC	B	1	2	3	U
NO HEAT	<input type="checkbox"/>	<input type="checkbox"/>	<input type="checkbox"/>	<input type="checkbox"/>	<input type="checkbox"/>
CTRL HEAT	<input type="checkbox"/>	<input type="checkbox"/>	<input type="checkbox"/>	<input type="checkbox"/>	<input type="checkbox"/>
HW/STEAM	<input type="checkbox"/>	<input type="checkbox"/>	<input type="checkbox"/>	<input type="checkbox"/>	<input type="checkbox"/>
ELECTRIC	<input type="checkbox"/>	<input type="checkbox"/>	<input type="checkbox"/>	<input type="checkbox"/>	<input type="checkbox"/>
HEAT PUMP	<input type="checkbox"/>	<input type="checkbox"/>	<input type="checkbox"/>	<input type="checkbox"/>	<input type="checkbox"/>
FLR/WALL	<input type="checkbox"/>	<input type="checkbox"/>	<input type="checkbox"/>	<input type="checkbox"/>	<input type="checkbox"/>
STVE/SPCE	<input type="checkbox"/>	<input type="checkbox"/>	<input type="checkbox"/>	<input type="checkbox"/>	<input type="checkbox"/>
GEO THERMAL	<input type="checkbox"/>	<input type="checkbox"/>	<input type="checkbox"/>	<input type="checkbox"/>	<input type="checkbox"/>
OUTSIDE	<input type="checkbox"/>	<input type="checkbox"/>	<input type="checkbox"/>	<input type="checkbox"/>	<input type="checkbox"/>
CTRL A/C	<input type="checkbox"/>	<input type="checkbox"/>	<input type="checkbox"/>	<input type="checkbox"/>	<input type="checkbox"/>
PLUMBING	BASE <input type="checkbox"/>				
X FULL BATH					
X HALF BATH					
X FIXTURES					

<b>SUBTOTAL</b>		0
MULTI-FAMILY #	0	0
BUILDING TYPE	000%	0
BSMT FINISH	0 S.F.	0
FIREPLACE #	0	0
HEATING	0 S.F.	0
AIR COND	0 S.F.	0
PLUMBING #	0	0
GARAGES & CARPORTS		0
EXTRA FEATURES		0
<b>SUBTOTAL</b>		0
GRADE FACTOR		%
<b>UNADJUSTED VALUE</b>		0
FACTOR		%

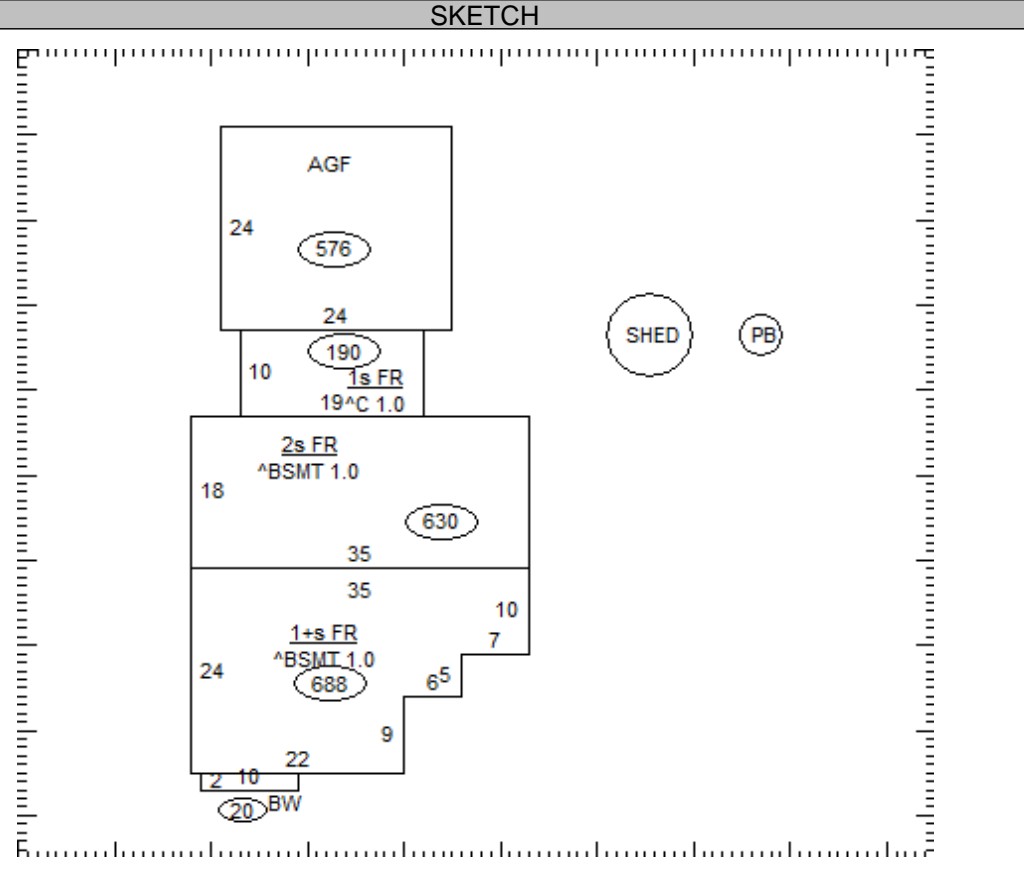

OCCUPANCY	ST.HT	SIZE	AREA	GRADE	PRICE	AGE	REMD	CND	UNADJ VAL	PHYS	PHYS VAL	FUNC	TRUE VAL
DWELLING		SK											
1													
2													
3													
4													
5													
6													
7													
8													
9													
10													
11													

09-116600.0000

TOTAL 0

COMMENTS