

FRANKLIN TWP / CELINA SD

09-20-334-025

09-051800.2500

**MORLEY CHRIS & AMANDA**  
MORLEY CHRIS & AMANDA  
5175 SOUTH LAKE CT  
CELINA, OH 45822

**LEGAL INFORMATION**  
HILLSIDE NORTH

LOT#: 25

Created in 2003 From - . 0 due to Split

	OWNERSHIP	ADDRESS	CITY	STATE	ZIP	DATE	AMOUNT	DEED:CONV#	JS	VALID
1	MORLEY CHRIS & AMANDA	5175 SOUTH LAKE CT	CELINA	OH	45822	03/19/2021	312,000	WDC : 196	<input type="checkbox"/>	<input checked="" type="checkbox"/>
2	TWO SHIPS LLC	5175 SOUTH LAKE CT	CELINA	OH	45822	03/19/2021	0	QCE : X : 0	<input type="checkbox"/>	<input type="checkbox"/>
3	TWO SHIPS LLC KEITH & SHEILA WESTRICK LIFE ESTATE	5175 SOUTH LAKE CT	CELINA	OH	45822	08/23/2017	0	4:QCE : X : 0	<input type="checkbox"/>	<input type="checkbox"/>

X:  TTO LISTER: JK DATE: 02/22/2016 TIME: 12:00:00 AM  LETTER  LETTER REC'D GIS CODE

STREET/ROAD	TOPOGRAPHY	PU-UTILITIES-PR	NEIGHBORHOOD	INFLUENCE FACTORS				PROPERTY LOCATION	
<input checked="" type="checkbox"/> PAVED <input type="checkbox"/> GRAVEL <input type="checkbox"/> DIRT <input type="checkbox"/> SIDEWALKS <input type="checkbox"/> CURBS	<input checked="" type="checkbox"/> LEVEL <input type="checkbox"/> HIGH <input type="checkbox"/> LOW <input type="checkbox"/> ROLLING <input type="checkbox"/> STANDARD	<input type="checkbox"/> WATER <input type="checkbox"/> SEWER <input type="checkbox"/> GAS <input type="checkbox"/> ELECTRIC <input checked="" type="checkbox"/> STANDARD	<input type="checkbox"/> IMPROVING <input type="checkbox"/> STATIC <input type="checkbox"/> DECLINING <input type="checkbox"/> OLD <input checked="" type="checkbox"/> STANDARD	<input type="checkbox"/> A. NO ROAD <input type="checkbox"/> B. TOPGRHY <input type="checkbox"/> C. Ex Front <input type="checkbox"/> D. QUANTITY <input type="checkbox"/> E. SZ/SHAPE	<input type="checkbox"/> F. RESTRICT <input type="checkbox"/> G. WOOD LT <input type="checkbox"/> H. VACANCY <input type="checkbox"/> I. WATER FRONT <input type="checkbox"/> J. OTHER/CDU	5175 SOUTH LAKE CT, CELINA			
COMMENT								TY2022:Net Gen=\$4,308.82, Other Assessment=\$0.00 DE16NOH/ RMV INC ON STP DE15 AD FP AND BATH PER DATA MAILER DE15 TTO/COR RM CNT, ADD AC DE15 NOH/EST 2ND FL IS FINISHED DE14 ADD DWLG & BOAT HSE//2ND FLOOR NOT FINISHED DE18 REMOVE OWN OCC didn't return app	
LAND TYPE		SIZE	M	RATE	C	INF	M	VALUE	C
F:Front		F122 D133	ST650	DP94	ADJ611			74,500	0
TOTAL								74,500	0

**VALUATION SUMMARY**

VALUE YEAR	2023	2020	2017				
REASON FOR CHANGE	RAPP	RAPP	RAPP				
APPRAISED VALUE	<u>LAND</u> 74,500	57,300	51,600				
	<u>IMPR</u> 267,100	198,900	171,200				
	<u>TOTAL</u> 341,600	256,200	222,800				
ASSESSED VALUE	<u>LAND</u> 26,080	20,060	18,060				
	<u>IMPR</u> 93,490	69,620	59,920				
	<u>TOTAL</u> 119,570	89,680	77,980				

<b>OCCUPANCY</b>	<b>EXTERIOR</b>	<b>FLOOR</b>	<b>AREA</b>	<b>CONST</b>	<b>VALUE</b>
<input checked="" type="checkbox"/> SF <input type="checkbox"/> DU <input type="checkbox"/> TR	<input type="checkbox"/> WOOD	1	1344	FR	192,140
<input type="checkbox"/> CONVERSION	<input type="checkbox"/> STUCCO	.5	672	FR	59,580
<b>BUILDING TYPE</b>	<input checked="" type="checkbox"/> ALM/VYNL				
<input type="checkbox"/> MOBILE HOME	<input type="checkbox"/> CONC BLK				
<input type="checkbox"/> BI/TR LEVEL	<input type="checkbox"/> METAL				
<input type="checkbox"/> MOD/MAN	<input type="checkbox"/> BRICK				
<input type="checkbox"/>	<input type="checkbox"/> STONE				

<b>ROOFING</b>	<b>ROOF TYPE</b>
<input type="checkbox"/> METAL	<input checked="" type="checkbox"/> GABLE
<input type="checkbox"/> SLT/TLE	<input type="checkbox"/> HIP
<input checked="" type="checkbox"/> SHINGLES	<input type="checkbox"/> GAMBREL
<input type="checkbox"/> SHAKES	<input type="checkbox"/> MANSARD
<input type="checkbox"/> COMPOSITE	<input type="checkbox"/> FLAT

<b>FLOORS</b>	<b>B</b>	<b>1</b>	<b>2</b>	<b>3</b>	<b>U</b>
CONCRETE	<input type="checkbox"/>	<input type="checkbox"/>	<input type="checkbox"/>	<input type="checkbox"/>	<input type="checkbox"/>
WOOD	<input type="checkbox"/>	<input type="checkbox"/>	<input type="checkbox"/>	<input type="checkbox"/>	<input type="checkbox"/>
TILE/COMPO	<input type="checkbox"/>	<input checked="" type="checkbox"/>	<input type="checkbox"/>	<input type="checkbox"/>	<input type="checkbox"/>
CARPET	<input type="checkbox"/>	<input checked="" type="checkbox"/>	<input type="checkbox"/>	<input type="checkbox"/>	<input type="checkbox"/>
<b>INT. FINISH</b>	<b>B</b>	<b>1</b>	<b>2</b>	<b>3</b>	<b>U</b>
PLASTER/DW	<input type="checkbox"/>	<input checked="" type="checkbox"/>	<input type="checkbox"/>	<input type="checkbox"/>	<input type="checkbox"/>
PANELING	<input type="checkbox"/>	<input type="checkbox"/>	<input type="checkbox"/>	<input type="checkbox"/>	<input type="checkbox"/>
UNFINISHED	<input type="checkbox"/>	<input type="checkbox"/>	<input type="checkbox"/>	<input type="checkbox"/>	<input type="checkbox"/>
<b>ACCOMMODATIONS</b>					
# OF ROOMS		3	2		
BEDROOMS		1	1		
FIREPLACES		1			
<b>HEAT &amp; AC</b>	<b>B</b>	<b>1</b>	<b>2</b>	<b>3</b>	<b>U</b>
NO HEAT	<input type="checkbox"/>	<input type="checkbox"/>	<input type="checkbox"/>	<input type="checkbox"/>	<input type="checkbox"/>
CTRL HEAT	<input type="checkbox"/>	<input checked="" type="checkbox"/>	<input checked="" type="checkbox"/>	<input type="checkbox"/>	<input type="checkbox"/>
HW/STEAM	<input type="checkbox"/>	<input type="checkbox"/>	<input type="checkbox"/>	<input type="checkbox"/>	<input type="checkbox"/>
ELECTRIC	<input type="checkbox"/>	<input type="checkbox"/>	<input type="checkbox"/>	<input type="checkbox"/>	<input type="checkbox"/>
HEAT PUMP	<input type="checkbox"/>	<input type="checkbox"/>	<input type="checkbox"/>	<input type="checkbox"/>	<input type="checkbox"/>
FLR/WALL	<input type="checkbox"/>	<input type="checkbox"/>	<input type="checkbox"/>	<input type="checkbox"/>	<input type="checkbox"/>
STVE/SPCE	<input type="checkbox"/>	<input type="checkbox"/>	<input type="checkbox"/>	<input type="checkbox"/>	<input type="checkbox"/>
GEOHERMAL	<input type="checkbox"/>	<input type="checkbox"/>	<input type="checkbox"/>	<input type="checkbox"/>	<input type="checkbox"/>
OUTSIDE	<input type="checkbox"/>	<input type="checkbox"/>	<input type="checkbox"/>	<input type="checkbox"/>	<input type="checkbox"/>
CTRL A/C	<input type="checkbox"/>	<input checked="" type="checkbox"/>	<input checked="" type="checkbox"/>	<input type="checkbox"/>	<input type="checkbox"/>
<b>PLUMBING</b>		<b>BASE</b> <input checked="" type="checkbox"/>			
X FULL BATH			1		
X HALF BATH		1			
X FIXTURES		1			

<b>SUBTOTAL</b>		251,720
MULTI-FAMILY #	0	0
BUILDING TYPE	100%	0
BSMT FINISH	0 S.F.	0
FIREPLACE #	1	4,400
HEATING	0 S.F.	0
AIR COND	2,016 S.F.	3,330
PLUMBING #	6	7,260
GARAGES & CARPORTS		21,400
EXTRA FEATURES		13,200
<b>SUBTOTAL</b>		301,310
GRADE FACTOR		100 %
<b>UNADJUSTED VALUE</b>		301,310
FACTOR		100 %

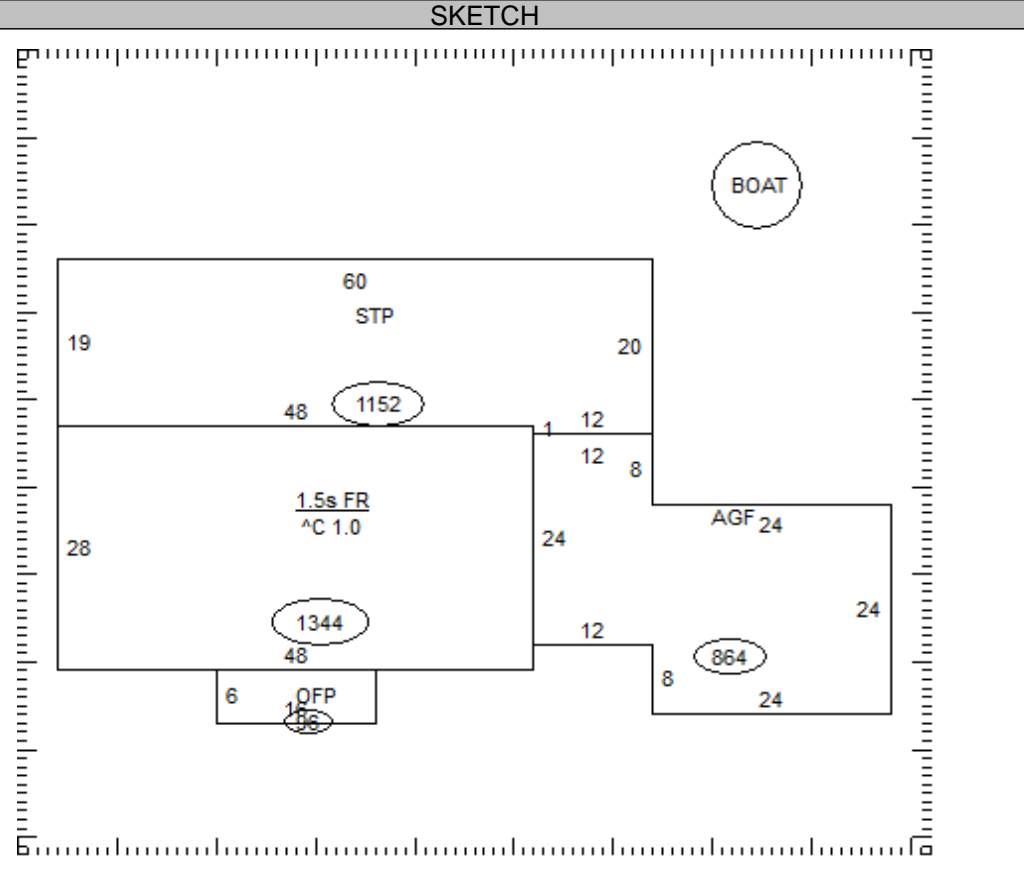

OCCUPANCY	ST.HT	SIZE	AREA	GRADE	PRICE	AGE	REMD	CND	UNADJ VAL	PHYS	PHYS VAL	FUNC	TRUE VAL
DWELLING	1.5	SK	2,016	C		2013		G	301,310	8	277,210		263,300
1 Boat House		24x25	600	C	7.49	2013		A	4,490	15	3,820		3,800
2													
3													
4													
5													
6													
7													
8													
9													
10													
11													

09-051800.2500	<b>TOTAL</b>	267,100
----------------	--------------	---------

**COMMENTS**

EX FIX- LAUNDRY TUB  
Dwelling has an Economic Factor of 95%

09-051800.2500

MORLEY CHRIS & AMANDA

MORLEY CHRIS & AMANDA

5175 SOUTH LAKE CT

CELINA, OH 45822

Created in 2003 From - . 0 due to Split

LEGAL INFORMATION

HILLSIDE NORTH

LOT#: 25

	OWNERSHIP	ADDRESS	CITY	STATE	ZIP	DATE	AMOUNT	DEED:CONV#	JS	VALID
1	WESTRICK SHEILA R KEITH WESTRICK LIFE ESTATE	5175 SOUTH LAKE CT	CELINA	OH	45822	08/23/2017	0	4:QCE : X : 0	<input type="checkbox"/>	<input type="checkbox"/>
2	WESTRICK KEITH A	5175 SOUTH LAKE CT	CELINA	OH	45822	08/23/2017	0	4:QCE : X : 0	<input type="checkbox"/>	<input type="checkbox"/>
3	WESTRICK KEITH A & SHEILA	5175 SOUTH LAKE CT	CELINA	OH	45822	07/27/2002	60,000	: A : 0	<input type="checkbox"/>	<input type="checkbox"/>

X:  TTO LISTER: JK DATE: 02/22/2016 TIME: 12:00:00 AM  LETTER  LETTER REC'D GIS CODE

STREET/ROAD		TOPOGRAPHY	PU-UTILITIES-PR	NEIGHBORHOOD	INFLUENCE FACTORS		PROPERTY LOCATION	
<input checked="" type="checkbox"/> PAVED	<input checked="" type="checkbox"/> LEVEL	<input type="checkbox"/> WATER	<input type="checkbox"/> IMPROVING	<input type="checkbox"/> A. NO ROAD	<input type="checkbox"/> F. RESTRICT	5175 SOUTH LAKE CT, CELINA		
<input type="checkbox"/> GRAVEL	<input type="checkbox"/> HIGH	<input type="checkbox"/> SEWER	<input type="checkbox"/> STATIC	<input type="checkbox"/> B. TOPGRHY	<input type="checkbox"/> G. WOOD LT	COMMENT		
<input type="checkbox"/> DIRT	<input type="checkbox"/> LOW	<input type="checkbox"/> GAS	<input type="checkbox"/> DECLINING	<input type="checkbox"/> C. Ex Front	<input type="checkbox"/> H. VACANCY			
<input type="checkbox"/> SIDEWALKS	<input type="checkbox"/> ROLLING	<input type="checkbox"/> ELECTRIC	<input type="checkbox"/> OLD	<input type="checkbox"/> D. QUANTITY	<input type="checkbox"/> I. WATER FRONT			
<input type="checkbox"/> CURBS	<input type="checkbox"/> STANDARD	<input checked="" type="checkbox"/> STANDARD	<input checked="" type="checkbox"/> STANDARD	<input type="checkbox"/> E. SZ/SHAPE	<input type="checkbox"/> J. OTHER/CDU			

LAND COMPUTATIONS							
LAND TYPE	SIZE	M	RATE	C	INF	M	VALUE C
TOTAL						74,500	0

VALUATION SUMMARY

VALUE YEAR							
REASON FOR CHANGE							
APPRaised	<u>LAND</u>						
VALUE	<u>IMPR</u>						
	<u>TOTAL</u>						
ASSESSED	<u>LAND</u>						
VALUE	<u>IMPR</u>						
	<u>TOTAL</u>						

OCCUPANCY				EXTERIOR			
<input type="checkbox"/> SF	<input type="checkbox"/> DU	<input type="checkbox"/> TR	<input type="checkbox"/>	<input type="checkbox"/> WOOD	<input type="checkbox"/>	<input type="checkbox"/>	<input type="checkbox"/>
CONVERSION				STUCCO			
BUILDING TYPE				ALM/VYNL			
<input type="checkbox"/> MOBILE HOME				<input type="checkbox"/> CONC BLK			
<input type="checkbox"/> BI/TR LEVEL				<input type="checkbox"/> METAL			
<input type="checkbox"/> MOD/MAN				<input type="checkbox"/> BRICK			
<input type="checkbox"/>				<input type="checkbox"/> STONE			

ROOFING				ROOF TYPE			
<input type="checkbox"/> METAL	<input type="checkbox"/>	<input type="checkbox"/>	<input type="checkbox"/>	<input type="checkbox"/> GABLE	<input type="checkbox"/>	<input type="checkbox"/>	<input type="checkbox"/>
<input type="checkbox"/> SLT/TLE	<input type="checkbox"/>	<input type="checkbox"/>	<input type="checkbox"/>	<input type="checkbox"/> HIP	<input type="checkbox"/>	<input type="checkbox"/>	<input type="checkbox"/>
<input type="checkbox"/> SHINGLES	<input type="checkbox"/>	<input type="checkbox"/>	<input type="checkbox"/>	<input type="checkbox"/> GAMBREL	<input type="checkbox"/>	<input type="checkbox"/>	<input type="checkbox"/>
<input type="checkbox"/> SHAKES	<input type="checkbox"/>	<input type="checkbox"/>	<input type="checkbox"/>	<input type="checkbox"/> MANSARD	<input type="checkbox"/>	<input type="checkbox"/>	<input type="checkbox"/>
<input type="checkbox"/> COMPOSITE	<input type="checkbox"/>	<input type="checkbox"/>	<input type="checkbox"/>	<input type="checkbox"/> FLAT	<input type="checkbox"/>	<input type="checkbox"/>	<input type="checkbox"/>

FLOORS						B	1	2	3	U
CONCRETE	<input type="checkbox"/>	<input type="checkbox"/>	<input type="checkbox"/>	<input type="checkbox"/>	<input type="checkbox"/>					
WOOD	<input type="checkbox"/>	<input type="checkbox"/>	<input type="checkbox"/>	<input type="checkbox"/>	<input type="checkbox"/>					
TILE/COMPO	<input type="checkbox"/>	<input type="checkbox"/>	<input type="checkbox"/>	<input type="checkbox"/>	<input type="checkbox"/>					
CARPET	<input type="checkbox"/>	<input type="checkbox"/>	<input type="checkbox"/>	<input type="checkbox"/>	<input type="checkbox"/>					

INT. FINISH						B	1	2	3	U
PLASTER/DW	<input type="checkbox"/>	<input type="checkbox"/>	<input type="checkbox"/>	<input type="checkbox"/>	<input type="checkbox"/>					
PANELING	<input type="checkbox"/>	<input type="checkbox"/>	<input type="checkbox"/>	<input type="checkbox"/>	<input type="checkbox"/>					
UNFINISHED	<input type="checkbox"/>	<input type="checkbox"/>	<input type="checkbox"/>	<input type="checkbox"/>	<input type="checkbox"/>					

ACCOMMODATIONS										
# OF ROOMS										
BEDROOMS										
FIREPLACES										
HEAT & AC						B	1	2	3	U
NO HEAT	<input type="checkbox"/>	<input type="checkbox"/>	<input type="checkbox"/>	<input type="checkbox"/>	<input type="checkbox"/>					
CTRL HEAT	<input type="checkbox"/>	<input type="checkbox"/>	<input type="checkbox"/>	<input type="checkbox"/>	<input type="checkbox"/>					
HW/STEAM	<input type="checkbox"/>	<input type="checkbox"/>	<input type="checkbox"/>	<input type="checkbox"/>	<input type="checkbox"/>					
ELECTRIC	<input type="checkbox"/>	<input type="checkbox"/>	<input type="checkbox"/>	<input type="checkbox"/>	<input type="checkbox"/>					
HEAT PUMP	<input type="checkbox"/>	<input type="checkbox"/>	<input type="checkbox"/>	<input type="checkbox"/>	<input type="checkbox"/>					
FLR/WALL	<input type="checkbox"/>	<input type="checkbox"/>	<input type="checkbox"/>	<input type="checkbox"/>	<input type="checkbox"/>					
STVE/SPCE	<input type="checkbox"/>	<input type="checkbox"/>	<input type="checkbox"/>	<input type="checkbox"/>	<input type="checkbox"/>					
GEOTHERMAL	<input type="checkbox"/>	<input type="checkbox"/>	<input type="checkbox"/>	<input type="checkbox"/>	<input type="checkbox"/>					
OUTSIDE	<input type="checkbox"/>	<input type="checkbox"/>	<input type="checkbox"/>	<input type="checkbox"/>	<input type="checkbox"/>					
CTRL A/C	<input type="checkbox"/>	<input type="checkbox"/>	<input type="checkbox"/>	<input type="checkbox"/>	<input type="checkbox"/>					

PLUMBING						BASE					<input type="checkbox"/>	
X FULL BATH												
X HALF BATH												
X FIXTURES												

FLOOR	AREA	CONST	VALUE
SUBTOTAL			0
MULTI-FAMILY #	0		0
BUILDING TYPE	000%		0
BSMT FINISH	0 S.F.		0
FIREPLACE #	0		0
HEATING	0 S.F.		0
AIR COND	0 S.F.		0
PLUMBING #	0		0
GARAGES & CARPORTS			0
EXTRA FEATURES			0
SUBTOTAL			0
GRADE FACTOR			%
UNADJUSTED VALUE			0
FACTOR			%

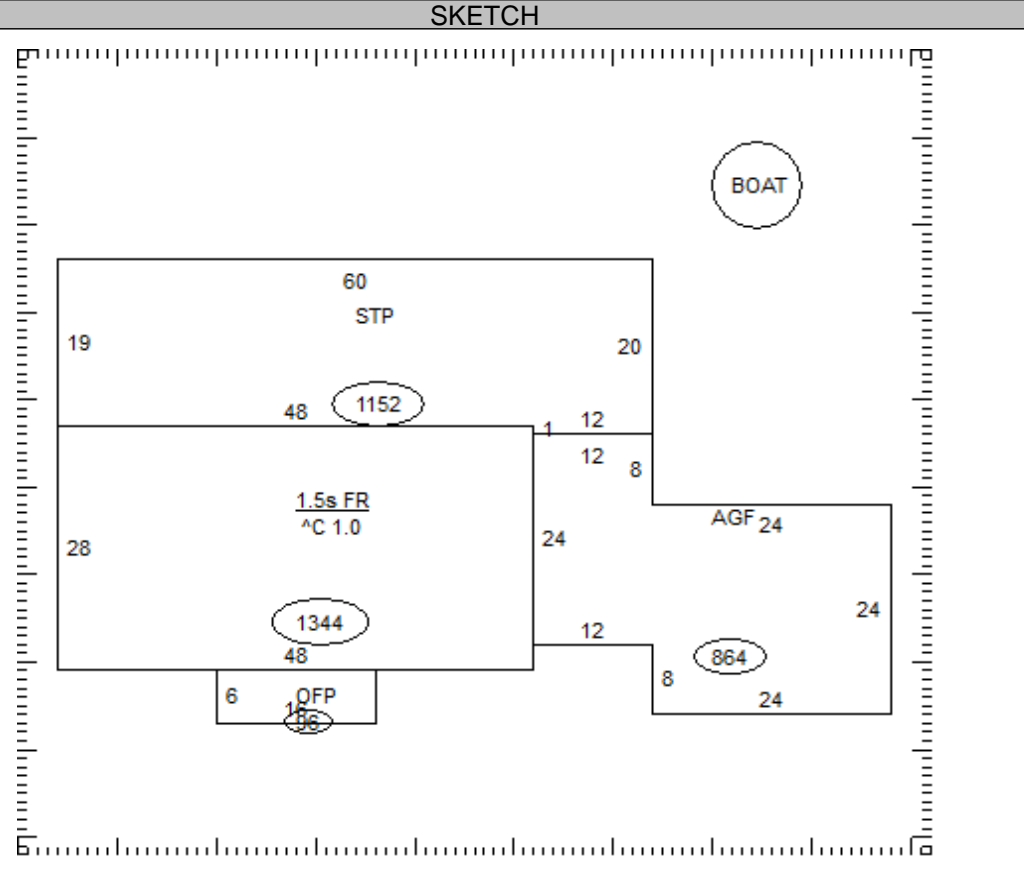

OCCUPANCY	ST.HT	SIZE	AREA	GRADE	PRICE	AGE	REMD	CND	UNADJ VAL	PHYS	PHYS VAL	FUNC	TRUE VAL
DWELLING		SK											
1													
2													
3													
4													
5													
6													
7													
8													
9													
10													
11													

09-051800.2500

TOTAL 0

COMMENTS