

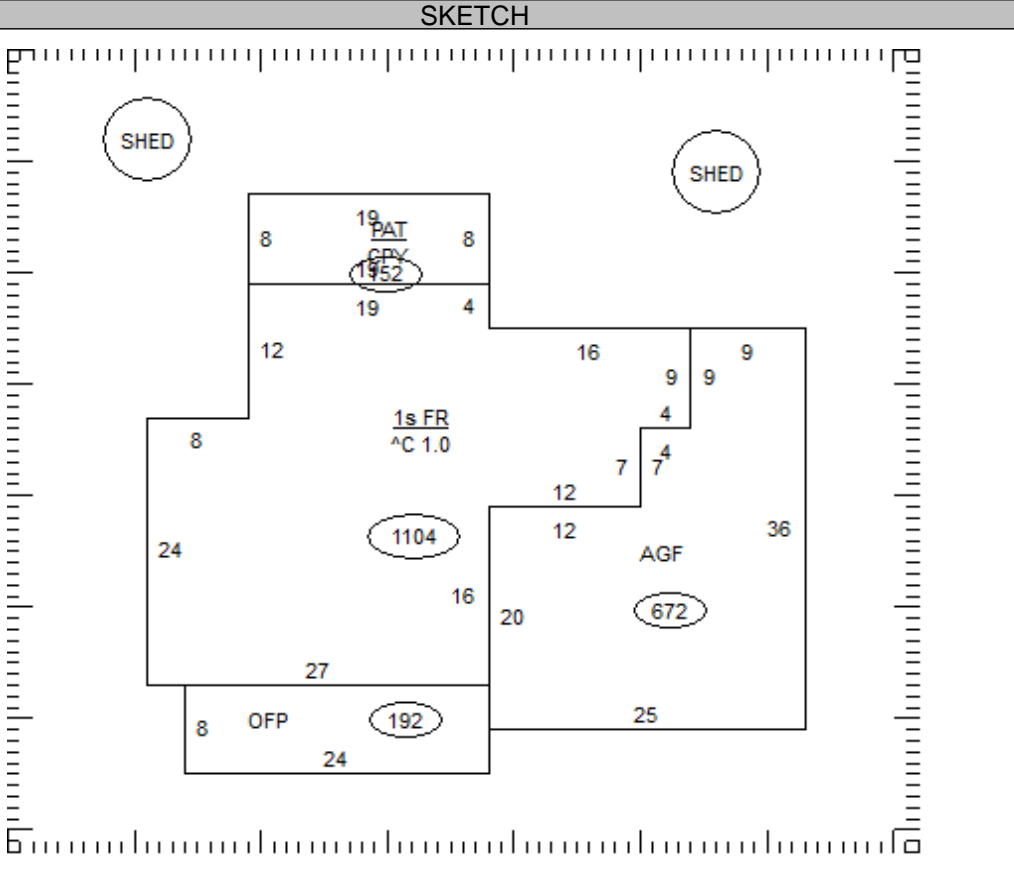

OCCUPANCY		EXTERIOR		FLOOR	AREA	CONST	VALUE
<input checked="" type="checkbox"/> SF	<input type="checkbox"/> DU	<input type="checkbox"/> TR	<input type="checkbox"/> WOOD	1	1104	FR	169,270
<input type="checkbox"/> CONVERSION		<input type="checkbox"/> STUCCO					
BUILDING TYPE		<input checked="" type="checkbox"/> ALM/VYNL					
<input type="checkbox"/> MOBILE HOME		<input type="checkbox"/> CONC BLK					
<input type="checkbox"/> BI/TR LEVEL		<input type="checkbox"/> METAL					
<input type="checkbox"/> MOD/MAN		<input type="checkbox"/> BRICK					
<input type="checkbox"/> _____		<input type="checkbox"/> STONE					
ROOFING		ROOF TYPE					
<input type="checkbox"/> METAL		<input checked="" type="checkbox"/> GABLE					
<input type="checkbox"/> SLT/TLE		<input type="checkbox"/> HIP					
<input checked="" type="checkbox"/> SHINGLES		<input type="checkbox"/> GAMBREL					
<input type="checkbox"/> SHAKES		<input type="checkbox"/> MANSARD					
<input type="checkbox"/> COMPOSITE		<input type="checkbox"/> FLAT					

SUBTOTAL			169,270
MULTI-FAMILY #	0		0
BUILDING TYPE	100%		0
BSMT FINISH	0 S.F.		0
FIREPLACE #	0		0
HEATING	0 S.F.		0
AIR COND	1,104 S.F.		1,820
PLUMBING #	3		3,630
GARAGES & CARPORTS			16,600
EXTRA FEATURES			4,800
SUBTOTAL			196,120
GRADE FACTOR			100 %
UNADJUSTED VALUE			196,120
FACTOR			100 %



OCCUPANCY	ST.HT	SIZE	AREA	GRADE	PRICE	AGE	REMD	CND	UNADJ VAL	PHYS	PHYS VAL	FUNC	TRUE VAL
DWELLING	1	SK	1,104	C		1956	1986	A	196,120	35	127,480		133,900
1 Shed	PP	4x12	48	C		1990		A		57			0
2 Shed		12x6	72	C		1990		A		57			0
3													
4													
5													
6													
7													
8													
9													
10													
11													

09-033800.0000	TOTAL	133,900
----------------	-------	---------

**COMMENTS**

Dwelling has an Economic Factor of 105%

Property Class: 510

Neighborhood  
095CL50-CL50

Map: 05 E

Block:

Card: 131

Bk: Pg:

FRANKLIN TWP / CELINA SD

09-20-283-007



09-033800.0000

**KISER JAMES D**  
KISER JAMES D  
5319 KARAFIT RD  
CELINA, OH 45822

**LEGAL INFORMATION**  
DAVIS ADDITION  
LOT 5 & PT LOT 4  
RTS: 003-06-20

**QUALIFIED CREDITS:**  
**HOMESTEAD**

	OWNERSHIP	ADDRESS	CITY	STATE	ZIP	DATE	AMOUNT	DEED:CONV#	JS	VALID
1	NICHOLS KENNETH J & MARY	5319 KARAFIT RD	CELINA	OH	45822	08/13/1990	60,000	: A-M : 0	<input type="checkbox"/>	<input type="checkbox"/>
2							0	0	<input type="checkbox"/>	<input type="checkbox"/>
3							0	0	<input type="checkbox"/>	<input type="checkbox"/>

X:  TTO    LISTER: DA    DATE: 06/24/2005    TIME: 12:00:00 AM     LETTER     LETTER REC'D    GIS CODE

**STREET/ROAD**    **TOPOGRAPHY**    **PU-UTILITIES-PR**    **NEIGHBORHOOD**    **INFLUENCE FACTORS**    **PROPERTY LOCATION**

<input checked="" type="checkbox"/> PAVED	<input checked="" type="checkbox"/> LEVEL	<input type="checkbox"/> WATER	<input checked="" type="checkbox"/> IMPROVING	<input type="checkbox"/> A. NO ROAD	<input type="checkbox"/> F. RESTRICT
<input type="checkbox"/> GRAVEL	<input type="checkbox"/> HIGH	<input type="checkbox"/> SEWER	<input checked="" type="checkbox"/> STATIC	<input type="checkbox"/> B. TOPGRHY	<input type="checkbox"/> G. WOOD LT
<input type="checkbox"/> DIRT	<input type="checkbox"/> LOW	<input type="checkbox"/> GAS	<input type="checkbox"/> DECLINING	<input type="checkbox"/> C. Ex Front	<input type="checkbox"/> H. VACANCY
<input type="checkbox"/> SIDEWALKS	<input type="checkbox"/> ROLLING	<input checked="" type="checkbox"/> ELECTRIC	<input type="checkbox"/> OLD	<input type="checkbox"/> D. QUANTITY	<input type="checkbox"/> I. WATER FRONT
<input type="checkbox"/> CURBS	<input type="checkbox"/> STANDARD	<input type="checkbox"/> STANDARD	<input type="checkbox"/> STANDARD	<input type="checkbox"/> E. SZ/SHAPE	<input type="checkbox"/> J. OTHER/CDU

5319 KARAFIT RD, CELINA  
**COMMENT**

LAND COMPUTATIONS							
LAND TYPE	SIZE	M	RATE	C	INF	M	VALUE C
TOTAL							46,500 0

**VALUATION SUMMARY**

VALUE YEAR	REASON FOR CHANGE	APPRaised	IMPR	TOTAL	ASSESSED	IMPR	TOTAL

OCCUPANCY	EXTERIOR	FLOOR	AREA	CONST	VALUE
<input type="checkbox"/> SF <input type="checkbox"/> DU <input type="checkbox"/> TR	<input type="checkbox"/> WOOD				
<input type="checkbox"/> CONVERSION	<input type="checkbox"/> STUCCO				
<b>BUILDING TYPE</b>	<input type="checkbox"/> ALM/VYNL				
<input type="checkbox"/> MOBILE HOME	<input type="checkbox"/> CONC BLK				
<input type="checkbox"/> BI/TR LEVEL	<input type="checkbox"/> METAL				
<input type="checkbox"/> MOD/MAN	<input type="checkbox"/> BRICK				
<input type="checkbox"/>	<input type="checkbox"/> STONE				
ROOFING	ROOF TYPE				
<input type="checkbox"/> METAL	<input type="checkbox"/> GABLE				
<input type="checkbox"/> SLT/TLE	<input type="checkbox"/> HIP				
<input type="checkbox"/> SHINGLES	<input type="checkbox"/> GAMBREL				
<input type="checkbox"/> SHAKES	<input type="checkbox"/> MANSARD				
<input type="checkbox"/> COMPOSITE	<input type="checkbox"/> FLAT				

SUBTOTAL			0
MULTI-FAMILY #	0		0
BUILDING TYPE	000%		0
BSMT FINISH	0 S.F.		0
FIREPLACE #	0		0
HEATING	0 S.F.		0
AIR COND	0 S.F.		0
PLUMBING #	0		0
GARAGES & CARPORTS			0
EXTRA FEATURES			0
SUBTOTAL			0
GRADE FACTOR			%
UNADJUSTED VALUE			0
FACTOR			%

FLOORS	B	1	2	3	U
CONCRETE	<input type="checkbox"/>	<input type="checkbox"/>	<input type="checkbox"/>	<input type="checkbox"/>	<input type="checkbox"/>
WOOD	<input type="checkbox"/>	<input type="checkbox"/>	<input type="checkbox"/>	<input type="checkbox"/>	<input type="checkbox"/>
TILE/COMPO	<input type="checkbox"/>	<input type="checkbox"/>	<input type="checkbox"/>	<input type="checkbox"/>	<input type="checkbox"/>
CARPET	<input type="checkbox"/>	<input type="checkbox"/>	<input type="checkbox"/>	<input type="checkbox"/>	<input type="checkbox"/>
INT. FINISH	B	1	2	3	U
PLASTER/DW	<input type="checkbox"/>	<input type="checkbox"/>	<input type="checkbox"/>	<input type="checkbox"/>	<input type="checkbox"/>
PANELING	<input type="checkbox"/>	<input type="checkbox"/>	<input type="checkbox"/>	<input type="checkbox"/>	<input type="checkbox"/>
UNFINISHED	<input type="checkbox"/>	<input type="checkbox"/>	<input type="checkbox"/>	<input type="checkbox"/>	<input type="checkbox"/>
ACCOMMODATIONS					
# OF ROOMS					
BEDROOMS					
FIREPLACES					
HEAT & AC	B	1	2	3	U
NO HEAT	<input type="checkbox"/>	<input type="checkbox"/>	<input type="checkbox"/>	<input type="checkbox"/>	<input type="checkbox"/>
CTRL HEAT	<input type="checkbox"/>	<input type="checkbox"/>	<input type="checkbox"/>	<input type="checkbox"/>	<input type="checkbox"/>
HW/STEAM	<input type="checkbox"/>	<input type="checkbox"/>	<input type="checkbox"/>	<input type="checkbox"/>	<input type="checkbox"/>
ELECTRIC	<input type="checkbox"/>	<input type="checkbox"/>	<input type="checkbox"/>	<input type="checkbox"/>	<input type="checkbox"/>
HEAT PUMP	<input type="checkbox"/>	<input type="checkbox"/>	<input type="checkbox"/>	<input type="checkbox"/>	<input type="checkbox"/>
FLR/WALL	<input type="checkbox"/>	<input type="checkbox"/>	<input type="checkbox"/>	<input type="checkbox"/>	<input type="checkbox"/>
STVE/SPCE	<input type="checkbox"/>	<input type="checkbox"/>	<input type="checkbox"/>	<input type="checkbox"/>	<input type="checkbox"/>
GEO THERMAL	<input type="checkbox"/>	<input type="checkbox"/>	<input type="checkbox"/>	<input type="checkbox"/>	<input type="checkbox"/>
OUTSIDE	<input type="checkbox"/>	<input type="checkbox"/>	<input type="checkbox"/>	<input type="checkbox"/>	<input type="checkbox"/>
CTRL A/C	<input type="checkbox"/>	<input type="checkbox"/>	<input type="checkbox"/>	<input type="checkbox"/>	<input type="checkbox"/>
PLUMBING					
X FULL BATH					
X HALF BATH					
X FIXTURES					

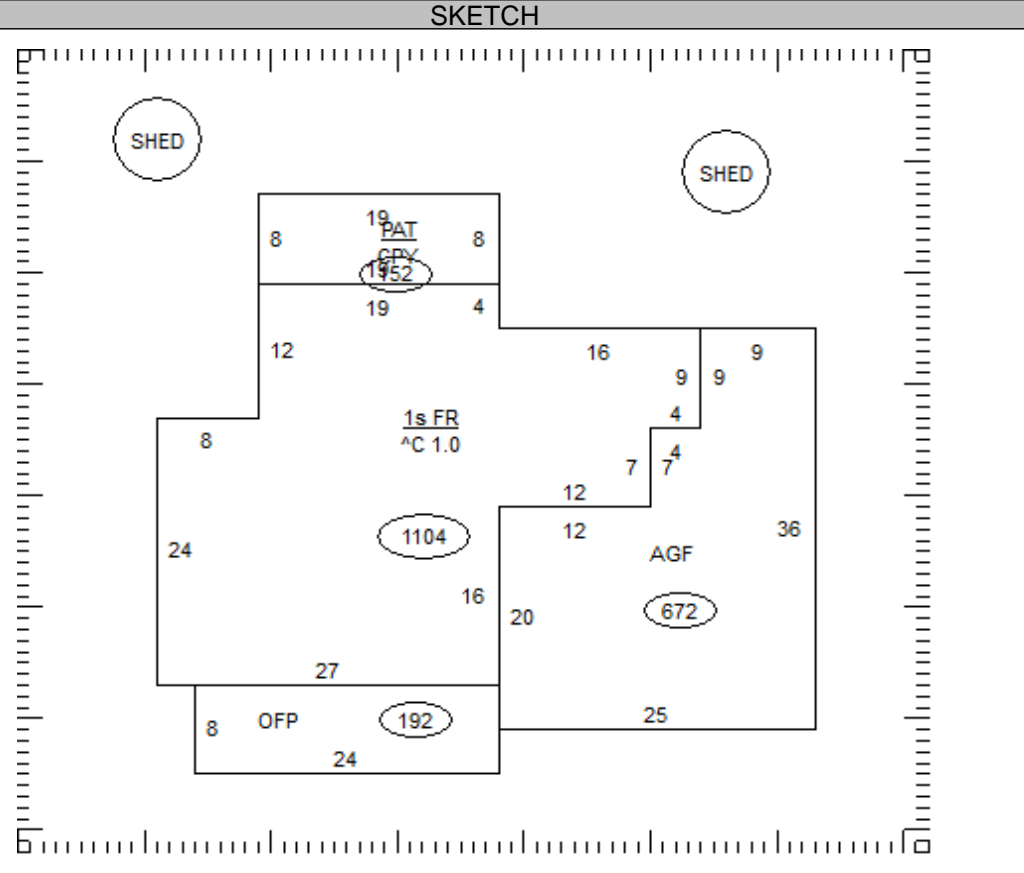

OCCUPANCY	ST.HT	SIZE	AREA	GRADE	PRICE	AGE	REMD	CND	UNADJ VAL	PHYS	PHYS VAL	FUNC	TRUE VAL
DWELLING		SK											
1													
2													
3													
4													
5													
6													
7													
8													
9													
10													
11													

09-033800.0000

TOTAL 0

COMMENTS