

09-012000.0000

HEMMELGARN LARRY J & HEMMELGARN ERIC TRU
HEMMELGARN LARRY J & HEMMELGARN ERIC TRU
350 PARK DR
DAYTON, OH 45410

LEGAL INFORMATION
S END NW SE PT

RTS: 003-06-19
Acres:0.2900 M:0.0000

	OWNERSHIP	ADDRESS	CITY	STATE	ZIP	DATE	AMOUNT	DEED:CONV#	JS	VALID
1	HEMMELGARN LARRY J &	350 PARK DR	DAYTON	OH	45410	12/27/2017	0	QCE : X : 0	<input type="checkbox"/>	<input type="checkbox"/>
2	HEMMELGARN LOIS A TRUST	3804 PHILOTHEA RD	COLDWATER	OH	45828	06/25/1998	0	: X : 0	<input type="checkbox"/>	<input type="checkbox"/>
3							0	0	<input type="checkbox"/>	<input type="checkbox"/>

X: TTO LISTER: DA DATE: 06/01/2005 TIME: 12:00:00 AM LETTER LETTER REC'D GIS CODE

STREET/ROAD	TOPOGRAPHY	PU-UTILITIES-PR	NEIGHBORHOOD	INFLUENCE FACTORS	PROPERTY LOCATION	
<input checked="" type="checkbox"/> PAVED <input type="checkbox"/> GRAVEL <input type="checkbox"/> DIRT <input type="checkbox"/> SIDEWALKS <input type="checkbox"/> CURBS	<input checked="" type="checkbox"/> LEVEL <input type="checkbox"/> HIGH <input type="checkbox"/> LOW <input type="checkbox"/> ROLLING <input type="checkbox"/> STANDARD	<input type="checkbox"/> WATER <input type="checkbox"/> SEWER <input checked="" type="checkbox"/> GAS <input checked="" type="checkbox"/> ELECTRIC <input type="checkbox"/> STANDARD	<input type="checkbox"/> IMPROVING <input checked="" type="checkbox"/> STATIC <input type="checkbox"/> DECLINING <input type="checkbox"/> OLD <input type="checkbox"/> STANDARD	<input type="checkbox"/> A. NO ROAD <input type="checkbox"/> B. TOPGRHY <input checked="" type="checkbox"/> C. Ex Front <input type="checkbox"/> D. QUANTITY <input type="checkbox"/> E. SZ/SHAPE	<input type="checkbox"/> F. RESTRICT <input type="checkbox"/> G. WOOD LT <input type="checkbox"/> H. VACANCY <input type="checkbox"/> I. WATER FRONT <input type="checkbox"/> J. OTHER/CDU	5182 BASS DR COMMENT TY2022:Net Gen=\$2,475.36, Other Assessment=\$0.00 DE22 ADD AC PER DATA MAILER

LAND COMPUTATIONS

LAND TYPE	SIZE	M	RATE	C	INF	M	VALUE	C
F:Front	F134 D112	ST440	DP86	ADJ378	C:0.1		45,600	0
TOTAL							45,600	0

VALUATION SUMMARY

VALUE YEAR	2023	2022	2020	2017	2017			
REASON FOR CHANGE	RAPP	MISC	RAPP	RAPP	MISC			
APPRAISED VALUE	<u>LAND</u> 45,600	41,800	41,800	38,300	39,900			
	<u>IMPR</u> 164,400	105,400	104,000	91,100	97,400			
	<u>TOTAL</u> 210,000	147,200	145,800	129,400	137,300			
ASSESSED VALUE	<u>LAND</u> 15,960	14,630	14,630	13,410	13,970			
	<u>IMPR</u> 57,540	36,890	36,400	31,890	34,090			
	<u>TOTAL</u> 73,500	51,520	51,030	45,300	48,060			

OCCUPANCY		EXTERIOR	
<input type="checkbox"/> SF	<input type="checkbox"/> DU	<input type="checkbox"/> TR	<input type="checkbox"/> WOOD
<input type="checkbox"/> CONVERSION			<input type="checkbox"/> STUCCO
BUILDING TYPE		<input checked="" type="checkbox"/> ALM/VYNL	
<input type="checkbox"/> MOBILE HOME			<input type="checkbox"/> CONC BLK
<input type="checkbox"/> BI/TR LEVEL			<input type="checkbox"/> METAL
<input type="checkbox"/> MOD/MAN			<input checked="" type="checkbox"/> BRICK
<input type="checkbox"/>			<input type="checkbox"/> STONE

ROOFING		ROOF TYPE	
<input type="checkbox"/> METAL			<input checked="" type="checkbox"/> GABLE
<input type="checkbox"/> SLT/TLE			<input type="checkbox"/> HIP
<input checked="" type="checkbox"/> SHINGLES			<input type="checkbox"/> GAMBREL
<input type="checkbox"/> SHAKES			<input type="checkbox"/> MANSARD
<input type="checkbox"/> COMPOSITE			<input type="checkbox"/> FLAT

FLOORS		B	1	2	3	U
CONCRETE	<input type="checkbox"/>	<input type="checkbox"/>	<input type="checkbox"/>	<input type="checkbox"/>	<input type="checkbox"/>	<input type="checkbox"/>
WOOD	<input type="checkbox"/>	<input type="checkbox"/>	<input type="checkbox"/>	<input type="checkbox"/>	<input type="checkbox"/>	<input type="checkbox"/>
TILE/COMPO	<input type="checkbox"/>	<input type="checkbox"/>	<input type="checkbox"/>	<input type="checkbox"/>	<input type="checkbox"/>	<input type="checkbox"/>
CARPET	<input type="checkbox"/>	<input checked="" type="checkbox"/>	<input checked="" type="checkbox"/>	<input type="checkbox"/>	<input type="checkbox"/>	<input type="checkbox"/>

INT. FINISH		B	1	2	3	U
PLASTER/DW	<input type="checkbox"/>	<input checked="" type="checkbox"/>	<input checked="" type="checkbox"/>	<input type="checkbox"/>	<input type="checkbox"/>	<input type="checkbox"/>
PANELING	<input type="checkbox"/>	<input checked="" type="checkbox"/>	<input checked="" type="checkbox"/>	<input type="checkbox"/>	<input type="checkbox"/>	<input type="checkbox"/>
UNFINISHED	<input type="checkbox"/>	<input type="checkbox"/>	<input type="checkbox"/>	<input type="checkbox"/>	<input type="checkbox"/>	<input type="checkbox"/>

ACCOMMODATIONS						
# OF ROOMS			6			
BEDROOMS			2			
FIREPLACES			1			

HEAT & AC		B	1	2	3	U
NO HEAT	<input type="checkbox"/>	<input type="checkbox"/>	<input type="checkbox"/>	<input type="checkbox"/>	<input type="checkbox"/>	<input type="checkbox"/>
CTRL HEAT	<input type="checkbox"/>	<input checked="" type="checkbox"/>	<input checked="" type="checkbox"/>	<input type="checkbox"/>	<input type="checkbox"/>	<input type="checkbox"/>
HW/STEAM	<input type="checkbox"/>	<input type="checkbox"/>	<input type="checkbox"/>	<input type="checkbox"/>	<input type="checkbox"/>	<input type="checkbox"/>
ELECTRIC	<input type="checkbox"/>	<input type="checkbox"/>	<input type="checkbox"/>	<input type="checkbox"/>	<input type="checkbox"/>	<input type="checkbox"/>
HEAT PUMP	<input type="checkbox"/>	<input type="checkbox"/>	<input type="checkbox"/>	<input type="checkbox"/>	<input type="checkbox"/>	<input type="checkbox"/>
FLR/WALL	<input type="checkbox"/>	<input type="checkbox"/>	<input type="checkbox"/>	<input type="checkbox"/>	<input type="checkbox"/>	<input type="checkbox"/>
STVE/SPCE	<input type="checkbox"/>	<input type="checkbox"/>	<input type="checkbox"/>	<input type="checkbox"/>	<input type="checkbox"/>	<input type="checkbox"/>
GEOHERMAL	<input type="checkbox"/>	<input type="checkbox"/>	<input type="checkbox"/>	<input type="checkbox"/>	<input type="checkbox"/>	<input type="checkbox"/>
OUTSIDE	<input type="checkbox"/>	<input type="checkbox"/>	<input type="checkbox"/>	<input type="checkbox"/>	<input type="checkbox"/>	<input type="checkbox"/>
CTRL A/C	<input type="checkbox"/>	<input checked="" type="checkbox"/>	<input checked="" type="checkbox"/>	<input type="checkbox"/>	<input type="checkbox"/>	<input type="checkbox"/>

PLUMBING		BASE		<input checked="" type="checkbox"/>
X FULL BATH	<input type="checkbox"/>	<input type="checkbox"/>	<input type="checkbox"/>	<input type="checkbox"/>
X HALF BATH	<input type="checkbox"/>	<input type="checkbox"/>	<input type="checkbox"/>	<input type="checkbox"/>
X FIXTURES	<input type="checkbox"/>	<input type="checkbox"/>	<input type="checkbox"/>	<input type="checkbox"/>

FLOOR	AREA	CONST	VALUE
1	126	FR	19,320
1	988	BRK	162,080
SUBTOTAL			181,400
MULTI-FAMILY #	0		0
BUILDING TYPE	100%		0
BSMT FINISH	0 S.F.		0
FIREPLACE #	1		4,400
HEATING	0 S.F.		0
AIR COND	1,114 S.F.		1,840
PLUMBING #	0		0
GARAGES & CARPORTS			21,900
EXTRA FEATURES			7,300
SUBTOTAL			216,840
GRADE FACTOR			105 %
UNADJUSTED VALUE			227,680
FACTOR			100 %

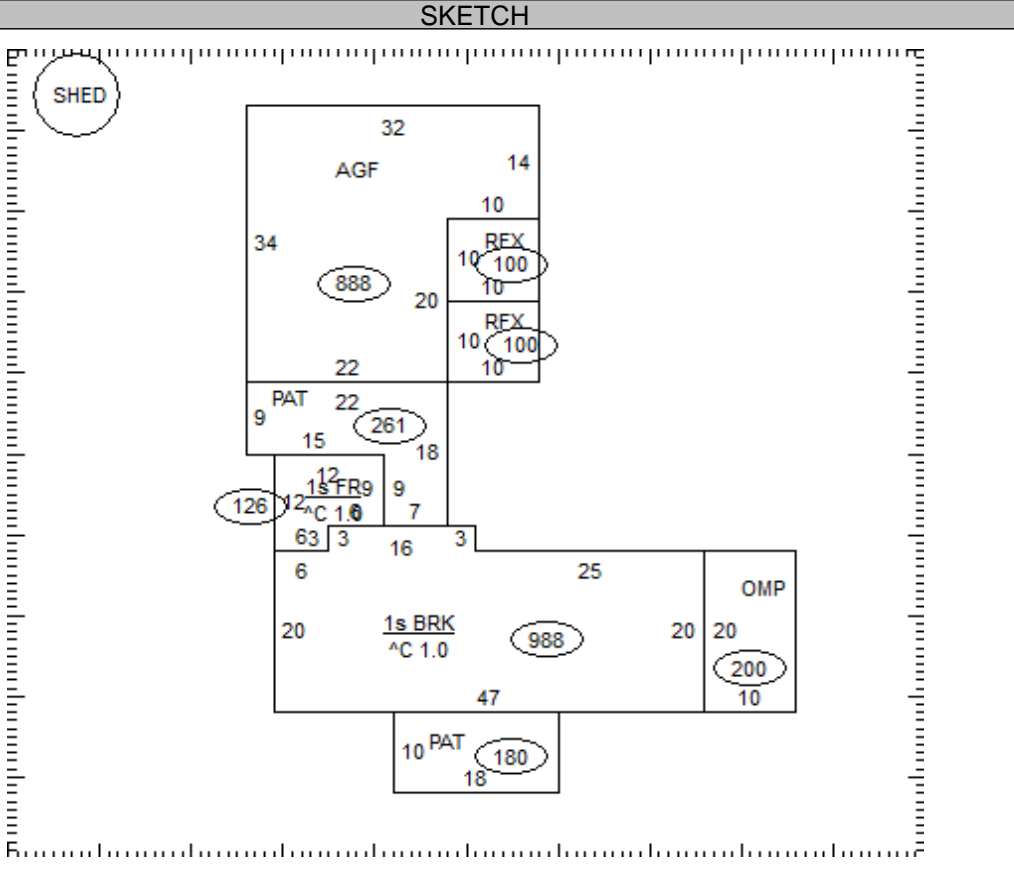

OCCUPANCY	ST.HT	SIZE	AREA	GRADE	PRICE	AGE	REMD	CND	UNADJ VAL	PHYS	PHYS VAL	FUNC	TRUE VAL
DWELLING	1	SK	1,114	C+		1984	2000	A	227,680	24	173,040		164,400
1 Shed		8x12	96	C		2000		A		37			0
2													
3													
4													
5													
6													
7													
8													
9													
10													
11													

09-012000.0000 TOTAL 164,400

COMMENTS

Dwelling has an Economic Factor of 95%