

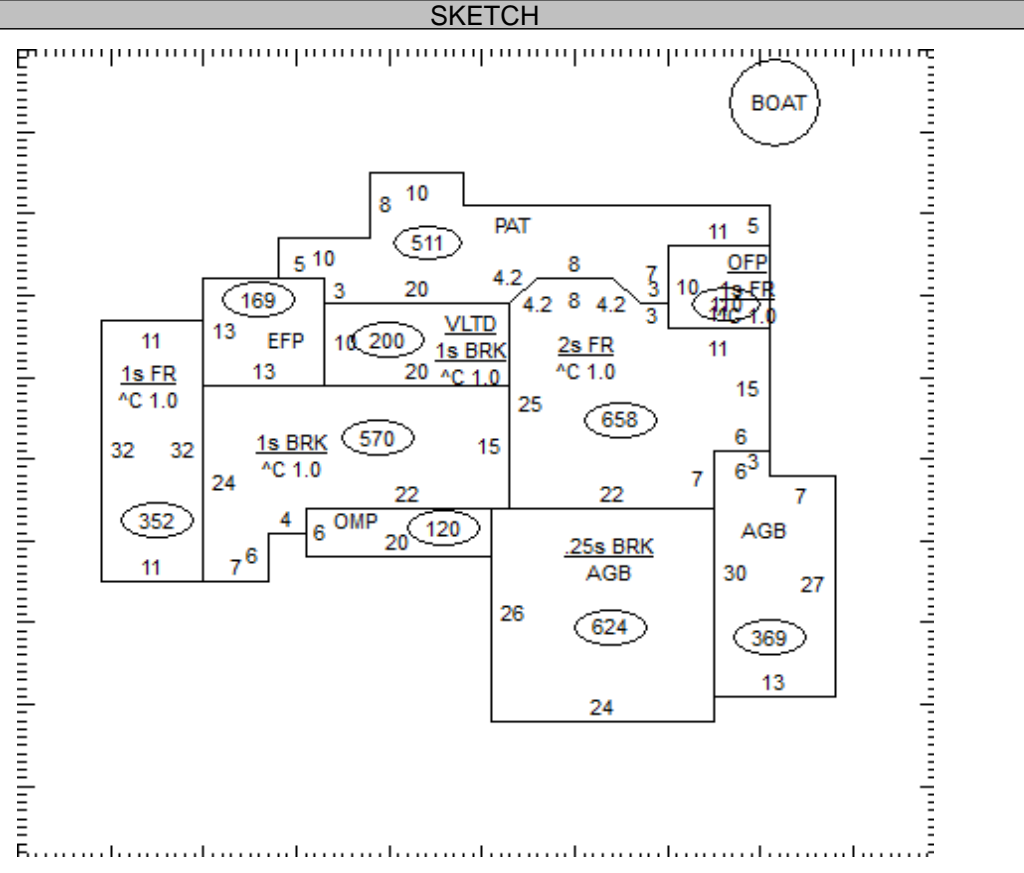

OCCUPANCY	EXTERIOR	FLOOR	AREA	CONST	VALUE
<input checked="" type="checkbox"/> SF <input type="checkbox"/> DU <input type="checkbox"/> TR	<input type="checkbox"/> WOOD	1	1120	FR	135,350
<input type="checkbox"/> CONVERSION	<input type="checkbox"/> STUCCO	1	770	BRK	99,580
<b>BUILDING TYPE</b>	<input type="checkbox"/> ALM/VYNL	.25	156	BRK	18,400
<input type="checkbox"/> MOBILE HOME	<input type="checkbox"/> CONC BLK	2ND	658	FR	38,170
<input type="checkbox"/> BI/TR LEVEL	<input type="checkbox"/> METAL				
<input type="checkbox"/> MOD/MAN	<input checked="" type="checkbox"/> BRICK				
<input type="checkbox"/>	<input type="checkbox"/> STONE				

ROOFING	ROOF TYPE
<input type="checkbox"/> METAL	<input type="checkbox"/> GABLE
<input type="checkbox"/> SLT/TLE	<input checked="" type="checkbox"/> HIP
<input checked="" type="checkbox"/> SHINGLES	<input type="checkbox"/> GAMBREL
<input type="checkbox"/> SHAKES	<input type="checkbox"/> MANSARD
<input type="checkbox"/> COMPOSITE	<input type="checkbox"/> FLAT

<b>SUBTOTAL</b>		291,500
MULTI-FAMILY #	0	0
BUILDING TYPE	100%	0
BSMT FINISH	0 S.F.	0
FIREPLACE #	1	4,400
HEATING	0 S.F.	0
AIR COND	1,584 S.F.	2,620
PLUMBING #	5	6,050
GARAGES & CARPORTS		27,700
EXTRA FEATURES		15,600
<b>SUBTOTAL</b>		347,870
GRADE FACTOR		165 %
<b>UNADJUSTED VALUE</b>		573,990
<b>FACTOR</b>		100 %



OCCUPANCY	ST.HT	SIZE	AREA	GRADE	PRICE	AGE	REMD	CND	UNADJ VAL	PHYS	PHYS VAL	FUNC	TRUE VAL
DWELLING	2	SK	2,704	A		1999		A	573,990	19	464,930		534,700
1 Boat House		32x42	1,344	B	8.99	2022		G	12,080	1	11,960		12,000
2													
3													
4													
5													
6													
7													
8													
9													
10													
11													

09-005400.2900	<b>TOTAL</b>	546,700
----------------	--------------	---------

**COMMENTS**

FRONTS ON WATER  
Dwelling has an Economic Factor of 115%