

| | | | |
|--|---|--|-------------------------------|
| OCCUPANCY | | EXTERIOR | |
| <input checked="" type="checkbox"/> SF | <input type="checkbox"/> DU | <input type="checkbox"/> TR | <input type="checkbox"/> WOOD |
| <input type="checkbox"/> CONVERSION | <input type="checkbox"/> STUCCO | | |
| BUILDING TYPE | | <input checked="" type="checkbox"/> ALM/VYNL | |
| <input type="checkbox"/> MOBILE HOME | <input type="checkbox"/> CONC BLK | | |
| <input type="checkbox"/> BI/TR LEVEL | <input type="checkbox"/> METAL | | |
| <input type="checkbox"/> MOD/MAN | <input type="checkbox"/> BRICK | | |
| <input type="checkbox"/> | <input checked="" type="checkbox"/> STONE | | |

| | | | |
|--|---|------------------|--|
| ROOFING | | ROOF TYPE | |
| <input type="checkbox"/> METAL | <input checked="" type="checkbox"/> GABLE | | |
| <input type="checkbox"/> SLT/TLE | <input type="checkbox"/> HIP | | |
| <input checked="" type="checkbox"/> SHINGLES | <input type="checkbox"/> GAMBREL | | |
| <input type="checkbox"/> SHAKES | <input type="checkbox"/> MANSARD | | |
| <input type="checkbox"/> COMPOSITE | <input type="checkbox"/> FLAT | | |

| | | | | | | |
|---------------|--------------------------|-------------------------------------|--------------------------|--------------------------|--------------------------|--------------------------|
| FLOORS | | B | 1 | 2 | 3 | U |
| CONCRETE | <input type="checkbox"/> | <input type="checkbox"/> | <input type="checkbox"/> | <input type="checkbox"/> | <input type="checkbox"/> | <input type="checkbox"/> |
| WOOD | <input type="checkbox"/> | <input type="checkbox"/> | <input type="checkbox"/> | <input type="checkbox"/> | <input type="checkbox"/> | <input type="checkbox"/> |
| TILE/COMPO | <input type="checkbox"/> | <input checked="" type="checkbox"/> | <input type="checkbox"/> | <input type="checkbox"/> | <input type="checkbox"/> | <input type="checkbox"/> |
| CARPET | <input type="checkbox"/> | <input checked="" type="checkbox"/> | <input type="checkbox"/> | <input type="checkbox"/> | <input type="checkbox"/> | <input type="checkbox"/> |

| | | | | | | |
|--------------------|--------------------------|-------------------------------------|--------------------------|--------------------------|--------------------------|--------------------------|
| INT. FINISH | | B | 1 | 2 | 3 | U |
| PLASTER/DW | <input type="checkbox"/> | <input checked="" type="checkbox"/> | <input type="checkbox"/> | <input type="checkbox"/> | <input type="checkbox"/> | <input type="checkbox"/> |
| PANELING | <input type="checkbox"/> | <input type="checkbox"/> | <input type="checkbox"/> | <input type="checkbox"/> | <input type="checkbox"/> | <input type="checkbox"/> |
| UNFINISHED | <input type="checkbox"/> | <input type="checkbox"/> | <input type="checkbox"/> | <input type="checkbox"/> | <input type="checkbox"/> | <input type="checkbox"/> |

| | | | | |
|-----------------------|---|---|---|---|
| ACCOMMODATIONS | | | | |
| # OF ROOMS | 7 | | | |
| BEDROOMS | 3 | | | |
| FIREPLACES | 1 | | | |
| HEAT & AC | | | | |
| B | 1 | 2 | 3 | U |

| | | | | | |
|-------------|--------------------------|-------------------------------------|--------------------------|--------------------------|--------------------------|
| NO HEAT | <input type="checkbox"/> | <input type="checkbox"/> | <input type="checkbox"/> | <input type="checkbox"/> | <input type="checkbox"/> |
| CTRL HEAT | <input type="checkbox"/> | <input checked="" type="checkbox"/> | <input type="checkbox"/> | <input type="checkbox"/> | <input type="checkbox"/> |
| HW/STEAM | <input type="checkbox"/> | <input type="checkbox"/> | <input type="checkbox"/> | <input type="checkbox"/> | <input type="checkbox"/> |
| ELECTRIC | <input type="checkbox"/> | <input type="checkbox"/> | <input type="checkbox"/> | <input type="checkbox"/> | <input type="checkbox"/> |
| HEAT PUMP | <input type="checkbox"/> | <input type="checkbox"/> | <input type="checkbox"/> | <input type="checkbox"/> | <input type="checkbox"/> |
| FLR/WALL | <input type="checkbox"/> | <input type="checkbox"/> | <input type="checkbox"/> | <input type="checkbox"/> | <input type="checkbox"/> |
| STVE/SPCE | <input type="checkbox"/> | <input type="checkbox"/> | <input type="checkbox"/> | <input type="checkbox"/> | <input type="checkbox"/> |
| GEO THERMAL | <input type="checkbox"/> | <input type="checkbox"/> | <input type="checkbox"/> | <input type="checkbox"/> | <input type="checkbox"/> |
| OUTSIDE | <input type="checkbox"/> | <input type="checkbox"/> | <input type="checkbox"/> | <input type="checkbox"/> | <input type="checkbox"/> |
| CTRL A/C | <input type="checkbox"/> | <input checked="" type="checkbox"/> | <input type="checkbox"/> | <input type="checkbox"/> | <input type="checkbox"/> |

| | | | |
|-----------------|---|-------------|--|
| PLUMBING | | BASE | |
| X FULL BATH | 1 | | |
| X HALF BATH | | | |
| X FIXTURES | | | |

| FLOOR | AREA | CONST | VALUE |
|-------------------------|------------|-------|---------|
| 1 | 2056 | FR | 237,800 |
| SUBTOTAL | | | 237,800 |
| MULTI-FAMILY # | 0 | | 0 |
| BUILDING TYPE | 100% | | 0 |
| BSMT FINISH | 0 S.F. | | 0 |
| FIREPLACE # | 1 | | 4,400 |
| HEATING | 0 S.F. | | 0 |
| AIR COND | 2,056 S.F. | | 3,390 |
| PLUMBING # | 3 | | 3,630 |
| GARAGES & CARPORTS | | | 10,900 |
| EXTRA FEATURES | | | 2,700 |
| SUBTOTAL | | | 262,820 |
| GRADE FACTOR | | | 105 % |
| UNADJUSTED VALUE | | | 275,960 |
| FACTOR | | | 100 % |

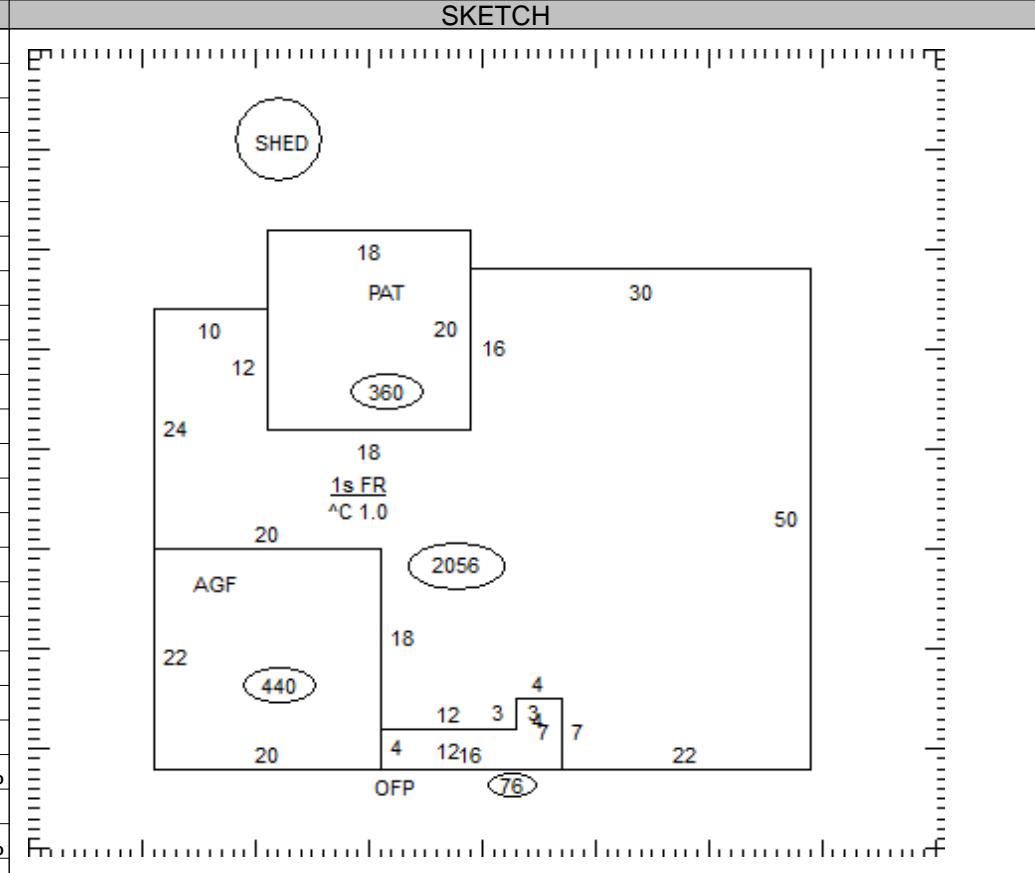

| OCCUPANCY | ST.HT | SIZE | AREA | GRADE | PRICE | AGE | REMD | CND | UNADJ VAL | PHYS | PHYS VAL | FUNC | TRUE VAL |
|-----------|-------|------|-------|-------|-------|------|------|-----|-----------|------|----------|------|----------|
| DWELLING | 1 | SK | 2,056 | C+ | | 1990 | | A | 275,960 | 26 | 204,210 | | 194,000 |
| 1 Shed | PP | 8x10 | 80 | C | | 2000 | | A | | 37 | | | 0 |
| 2 | | | | | | | | | | | | | |
| 3 | | | | | | | | | | | | | |
| 4 | | | | | | | | | | | | | |
| 5 | | | | | | | | | | | | | |
| 6 | | | | | | | | | | | | | |
| 7 | | | | | | | | | | | | | |
| 8 | | | | | | | | | | | | | |
| 9 | | | | | | | | | | | | | |
| 10 | | | | | | | | | | | | | |
| 11 | | | | | | | | | | | | | |

09-005400.1300

TOTAL 194,000

COMMENTS

FRAME W/MS
Dwelling has an Economic Factor of 95%

FRANKLIN TWP / CELINA SD

09-19-401-006

Property Class: 510

Neighborhood
095LA50-LA50

Map: 03
Block: 04
Card: 06

Bk: Pg:

09-005400.1300

MARBAUGH JERRY L & JUDITH M TRUSTEES
MARBAUGH JERRY L & JUDITH M TRUSTEES
5259 MONTEZUMA ACRES DR
CELINA, OH 45822

LEGAL INFORMATION
MONTEZUMA ACRES WEST

LOT#: 13

| | OWNERSHIP | ADDRESS | CITY | STATE | ZIP | DATE | AMOUNT | DEED:CONV# | JS | VALID |
|---|-------------------------|----------------------|--------|-------|------------|------------|--------|------------|--------------------------|-------------------------------------|
| 1 | KOHNEN NORBERT J & MARY | 5261 MONTEZUMA ACRES | CELINA | OH | 45822-9500 | 05/30/1989 | 89,500 | : A : 0 | <input type="checkbox"/> | <input checked="" type="checkbox"/> |
| 2 | | | | | | | 0 | 0 | <input type="checkbox"/> | <input type="checkbox"/> |
| 3 | | | | | | | 0 | 0 | <input type="checkbox"/> | <input type="checkbox"/> |

X: TTO LISTER: DA DATE: 06/03/2005 TIME: 12:00:00 AM LETTER LETTER REC'D GIS CODE

| STREET/ROAD | TOPOGRAPHY | PU-UTILITIES-PR | NEIGHBORHOOD | INFLUENCE FACTORS | PROPERTY LOCATION |
|---|---|--|--|--|---------------------------------|
| <input checked="" type="checkbox"/> PAVED | <input checked="" type="checkbox"/> LEVEL | <input type="checkbox"/> WATER <input type="checkbox"/> | <input type="checkbox"/> IMPROVING | <input type="checkbox"/> A. NO ROAD <input type="checkbox"/> F. RESTRICT | 5259 MONTEZUMA ACRES DR, CELINA |
| <input type="checkbox"/> GRAVEL | <input type="checkbox"/> HIGH | <input type="checkbox"/> SEWER <input type="checkbox"/> | <input checked="" type="checkbox"/> STATIC | <input type="checkbox"/> B. TOPGRHY <input type="checkbox"/> G. WOOD LT | COMMENT |
| <input type="checkbox"/> DIRT | <input type="checkbox"/> LOW | <input type="checkbox"/> GAS <input type="checkbox"/> | <input type="checkbox"/> DECLINING | <input type="checkbox"/> C. Ex Front <input type="checkbox"/> H. VACANCY | |
| <input type="checkbox"/> SIDEWALKS | <input type="checkbox"/> ROLLING | <input type="checkbox"/> ELECTRIC <input type="checkbox"/> | <input type="checkbox"/> OLD | <input type="checkbox"/> D. QUANTITY <input type="checkbox"/> I. WATER FRONT | |
| <input type="checkbox"/> CURBS | <input type="checkbox"/> STANDARD | <input checked="" type="checkbox"/> STANDARD | <input type="checkbox"/> STANDARD | <input type="checkbox"/> E. SZ/SHAPE <input type="checkbox"/> J. OTHER/CDU | |

| LAND COMPUTATIONS | | | | | | | |
|-------------------|------|---|------|---|-----|--------|---------|
| LAND TYPE | SIZE | M | RATE | C | INF | M | VALUE C |
| | | | | | | | |
| | | | | | | | |
| | | | | | | | |
| | | | | | | | |
| | | | | | | | |
| | | | | | | | |
| | | | | | | | |
| | | | | | | | |
| | | | | | | | |
| TOTAL | | | | | | 33,400 | 0 |

VALUATION SUMMARY

| VALUE YEAR | | | | | | | |
|-------------------|--------------|--|--|--|--|--|--|
| REASON FOR CHANGE | | | | | | | |
| APPRaised | <u>LAND</u> | | | | | | |
| VALUE | <u>IMPR</u> | | | | | | |
| | <u>TOTAL</u> | | | | | | |
| ASSESSED | <u>LAND</u> | | | | | | |
| VALUE | <u>IMPR</u> | | | | | | |
| | <u>TOTAL</u> | | | | | | |

