

09-16-451-001

FRANKLIN TWP / CELINA SD

09-000200.0101

HARRIS CORY J & BRANDY L

HARRIS CORY J & BRANDY L

5605 HIDDEN SHORES DR

CELINA, OH 45822

**LEGAL INFORMATION**

HIDDEN SHORES SEC 1

LOT#: 1

	OWNERSHIP	ADDRESS	CITY	STATE	ZIP	DATE	AMOUNT	DEED:CONV#	JS	VALID
1	HARRIS CORY J & BRANDY L	5605 HIDDEN SHORES DR	CELINA	OH	45822	07/02/2018	599,900	WDC : 474	<input type="checkbox"/>	<input checked="checked" type="checkbox"/>
2	HANES NICKLAS D & SHERI L	5605 WEST HIDDEN	CELINA	OH	45822	05/16/2016	450,000	WDC : 318	<input type="checkbox"/>	<input checked="checked" type="checkbox"/>
3	SHINDELDECKER JAMES L &	5605 W HIDDEN SHORES	CELINA	OH	45822	05/11/2001	282,500	: A : 0	<input type="checkbox"/>	<input type="checkbox"/>

X:	<input type="checkbox"/> TTO	LISTER:	DATE: 05/19/2021	TIME: 12:00:00 AM	<input type="checkbox"/> LETTER	<input type="checkbox"/> LETTER REC'D	GIS CODE
STREET/ROAD	TOPOGRAPHY	PU-UTILITIES-PR	NEIGHBORHOOD	INFLUENCE FACTORS		PROPERTY LOCATION	
<input checked="checked" type="checkbox"/> PAVED <input type="checkbox"/> GRAVEL <input type="checkbox"/> DIRT <input checked="checked" type="checkbox"/> SIDEWALKS <input checked="checked" type="checkbox"/> CURBS	<input checked="checked" type="checkbox"/> LEVEL <input type="checkbox"/> HIGH <input type="checkbox"/> LOW <input type="checkbox"/> ROLLING <input type="checkbox"/> STANDARD	<input type="checkbox"/> WATER <input type="checkbox"/> SEWER <input type="checkbox"/> GAS <input type="checkbox"/> ELECTRIC <input checked="checked" type="checkbox"/> STANDARD	<input checked="checked" type="checkbox"/> IMPROVING <input type="checkbox"/> STATIC <input type="checkbox"/> DECLINING <input type="checkbox"/> OLD <input type="checkbox"/> STANDARD	<input type="checkbox"/> A. NO ROAD <input type="checkbox"/> B. TOPGRHY <input type="checkbox"/> C. Ex Front <input type="checkbox"/> D. QUANTITY <input type="checkbox"/> E. SZ/SHAPE	<input type="checkbox"/> F. RESTRICT <input type="checkbox"/> G. WOOD LT <input type="checkbox"/> H. VACANCY <input type="checkbox"/> I. WATER FRONT <input type="checkbox"/> J. OTHER/CDU	5605 W HIDDEN SHORES DR	
<b>COMMENT</b>							
TY2022:Net Gen=\$8,857.40, Other Assessment=\$0.00 DE19 RMV OWN OCC; DID NOT RET APP DE21 ADJ LOT SIZE; CHG COND FROM AVG TO GOOD							
LAND COMPUTATIONS			LAND COMPUTATIONS				
LAND TYPE	SIZE	M	RATE	C	INF	M	VALUE C
F:Front	F126 D172	ST1730 DP107 ADJ1851				233,200	0
<b>TOTAL</b>						233,200	0

VALUATION SUMMARY									
VALUE YEAR		2023	2021	2020	2017				
REASON FOR CHANGE		RAPP	MISC	RAPP	RAPP				
APPRAISED	LAND	233,200	233,000	205,700	190,500				
VALUE	IMPR	533,400	293,700	284,200	272,300				
	TOTAL	766,600	526,700	489,900	462,800				
ASSESSED	LAND	81,620	81,550	72,000	66,680				
VALUE	IMPR	186,690	102,800	99,470	95,310				
	TOTAL	268,310	184,350	171,470	161,990				

<input type="checkbox"/> SF <input type="checkbox"/> DU <input type="checkbox"/> TR	<input type="checkbox"/> WOOD
<input type="checkbox"/> CONVERSION	<input type="checkbox"/> STUCCO
<b>BUILDING TYPE</b>	<input type="checkbox"/> ALM/VYNL
<input type="checkbox"/> MOBILE HOME	<input type="checkbox"/> CONC BLK
<input type="checkbox"/> BI/TR LEVEL	<input type="checkbox"/> METAL
<input type="checkbox"/> MOD/MAN	<input checked="" type="checkbox"/> BRICK
<input type="checkbox"/>	<input type="checkbox"/> STONE

<b>ROOFING</b>	<b>ROOF TYPE</b>
<input type="checkbox"/> METAL	<input type="checkbox"/> GABLE
<input type="checkbox"/> SLT/TLE	<input checked="" type="checkbox"/> HIP
<input checked="" type="checkbox"/> SHINGLES	<input type="checkbox"/> GAMBREL
<input type="checkbox"/> SHAKES	<input type="checkbox"/> MANSARD
<input type="checkbox"/> COMPOSITE	<input type="checkbox"/> FLAT

<b>FLOORS</b>	B	1	2	3	U
CONCRETE	<input type="checkbox"/>	<input type="checkbox"/>	<input type="checkbox"/>	<input type="checkbox"/>	<input type="checkbox"/>
WOOD	<input type="checkbox"/>	<input checked="" type="checkbox"/>	<input type="checkbox"/>	<input type="checkbox"/>	<input type="checkbox"/>
TILE/COMPO	<input type="checkbox"/>	<input checked="" type="checkbox"/>	<input checked="" type="checkbox"/>	<input type="checkbox"/>	<input type="checkbox"/>
CARPET	<input type="checkbox"/>	<input checked="" type="checkbox"/>	<input checked="" type="checkbox"/>	<input type="checkbox"/>	<input type="checkbox"/>

<b>INT. FINISH</b>	B	1	2	3	U
PLASTER/DW	<input type="checkbox"/>	<input checked="" type="checkbox"/>	<input checked="" type="checkbox"/>	<input type="checkbox"/>	<input type="checkbox"/>
PANELING	<input type="checkbox"/>	<input type="checkbox"/>	<input type="checkbox"/>	<input type="checkbox"/>	<input type="checkbox"/>
UNFINISHED	<input type="checkbox"/>	<input type="checkbox"/>	<input type="checkbox"/>	<input type="checkbox"/>	<input type="checkbox"/>

<b>ACCOMMODATIONS</b>					
# OF ROOMS		5	3		
BEDROOMS		1	3		
FIREPLACES		1			

<b>HEAT &amp; AC</b>	B	1	2	3	U
NO HEAT	<input type="checkbox"/>	<input type="checkbox"/>	<input type="checkbox"/>	<input type="checkbox"/>	<input type="checkbox"/>
CTRL HEAT	<input type="checkbox"/>	<input checked="" type="checkbox"/>	<input checked="" type="checkbox"/>	<input type="checkbox"/>	<input type="checkbox"/>
HW/STEAM	<input type="checkbox"/>	<input type="checkbox"/>	<input type="checkbox"/>	<input type="checkbox"/>	<input type="checkbox"/>
ELECTRIC	<input type="checkbox"/>	<input type="checkbox"/>	<input type="checkbox"/>	<input type="checkbox"/>	<input type="checkbox"/>
HEAT PUMP	<input type="checkbox"/>	<input type="checkbox"/>	<input type="checkbox"/>	<input type="checkbox"/>	<input type="checkbox"/>
FLR/WALL	<input type="checkbox"/>	<input type="checkbox"/>	<input type="checkbox"/>	<input type="checkbox"/>	<input type="checkbox"/>
STVE/SPCE	<input type="checkbox"/>	<input type="checkbox"/>	<input type="checkbox"/>	<input type="checkbox"/>	<input type="checkbox"/>
GEO THERMAL	<input type="checkbox"/>	<input type="checkbox"/>	<input type="checkbox"/>	<input type="checkbox"/>	<input type="checkbox"/>
OUTSIDE	<input type="checkbox"/>	<input type="checkbox"/>	<input type="checkbox"/>	<input type="checkbox"/>	<input type="checkbox"/>
CTRL A/C	<input type="checkbox"/>	<input checked="" type="checkbox"/>	<input checked="" type="checkbox"/>	<input type="checkbox"/>	<input type="checkbox"/>

<b>PLUMBING</b>	<b>BASE</b> <input checked="" type="checkbox"/>				
X FULL BATH		1	1		
X HALF BATH		1			
X FIXTURES					

FLOOR	AREA	CONST	VALUE
1	1855	BRK	239,890
2ND	1116	BRK	69,270
<b>SUBTOTAL</b>			309,160
MULTI-FAMILY #	0		0
BUILDING TYPE	100%		0
BSMT FINISH	0 S.F.		0
FIREPLACE #	1		4,400
HEATING	0 S.F.		0
AIR COND	2,971 S.F.		4,900
PLUMBING #	8		9,680
GARAGES & CARPORTS			32,400
EXTRA FEATURES			7,000
<b>SUBTOTAL</b>			367,540
GRADE FACTOR			165 %
<b>UNADJUSTED VALUE</b>			606,440
FACTOR			100 %

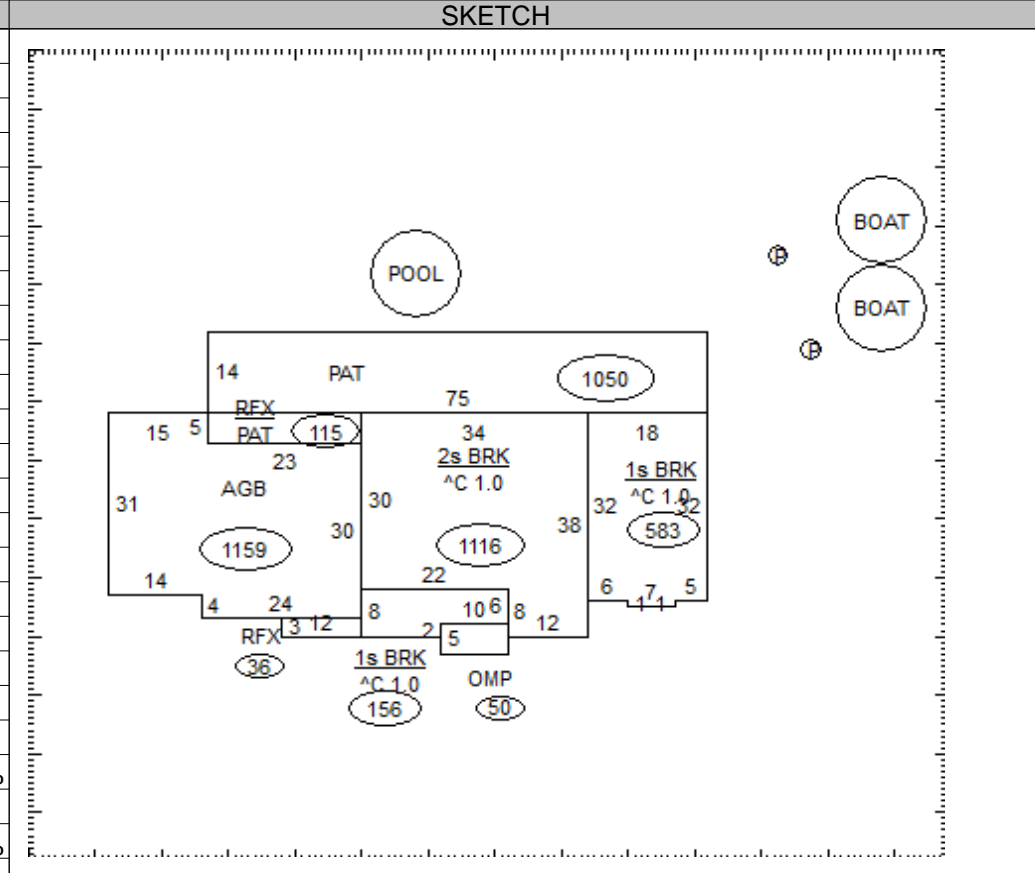

OCCUPANCY	ST.HT	SIZE	AREA	GRADE	PRICE	AGE	REMD	CND	UNADJ VAL	PHYS	PHYS VAL	FUNC	TRUE VAL
DWELLING	2	SK	2,971	A		2003		G	606,440	14	521,540		511,100
1 Boat House	10	16x12	192	C	7.49	2003		A	1,440	35	940		900
2 Pool - Inground		17x39	663	C	37.50	2003		A	24,860	35	16,160		16,200
3 Boat House	10	16x26	416	C	7.49	2003		A	3,120	35	2,030		2,000
4 Patio		0x0	1,014	C	4.05	2003		A	4,110	35	2,670		2,700
5 Patio		14x14	196	C	4.05	2003		A	790	35	510		500
6													
7													
8													
9													
10													
11													

09-000200.0101

TOTAL 533,400

**COMMENTS**  
 Dwelling has an Economic Factor of 98%