

Property Class: 510

Neighborhood  
095LF81

Map: 04

Block:

Card: 134

Bk: Pg:

FRANKLIN TWP / CELINA SD

09-16-379-004

09-000200.0100

**KELLY REBECCA K**  
KELLY REBECCA K  
5565 HIDDEN SHORES DR  
CELINA, OH 45822

**LEGAL INFORMATION**  
S SD S 1/2 SW

RTS: 003-06-16  
Acres:0.4640 M:0.0000

	OWNERSHIP	ADDRESS	CITY	STATE	ZIP	DATE	AMOUNT	DEED:CONV#	JS	VALID
1	KELLY REBECCA K	5565 HIDDEN SHORES DR	CELINA	OH	45822	06/07/2017	475,000	WDC : 374	<input type="checkbox"/>	<input checked="" type="checkbox"/>
2	HOMAN ROBERT B &	5565 W HIDDEN SHORES	CELINA	OH	45822-0	08/31/2001	155,000	: A : 0	<input type="checkbox"/>	<input checked="" type="checkbox"/>
3							0	0	<input type="checkbox"/>	<input type="checkbox"/>

X:  TTO LISTER: DATE: 05/11/2023 TIME: 12:00:00 AM  LETTER  LETTER REC'D GIS CODE

STREET/ROAD	TOPOGRAPHY	PU-UTILITIES-PR	NEIGHBORHOOD	INFLUENCE FACTORS				PROPERTY LOCATION			
<input checked="" type="checkbox"/> PAVED	<input checked="" type="checkbox"/> LEVEL	<input type="checkbox"/> WATER	<input type="checkbox"/> IMPROVING	<input type="checkbox"/> A. NO ROAD	<input type="checkbox"/> F. RESTRICT	5565 W HIDDEN SHORES DR, CELINA					
<input type="checkbox"/> GRAVEL	<input type="checkbox"/> HIGH	<input type="checkbox"/> SEWER	<input checked="" type="checkbox"/> STATIC	<input type="checkbox"/> B. TOPGRHY	<input type="checkbox"/> G. WOOD LT	<b>COMMENT</b> TY2022:Net Gen=\$8,476.62, Other Assessment=\$0.00 DE23 ADJ GRADE//DESKTOP RVW DE21 APPLY OWN OCC/LATE APP DE20 RMV BOR FNC DE11 CHANGE SKETCH & COND & GRD DE17 DESKTOP REVIEW//CORR SKETCH; ADD PATIO, OFP BOR: BOR 17-69 HEARING; REDUCE VALUE TO PURCHASE PRICE \$475,000, C.A.M.P. BOR 20-43					
<input type="checkbox"/> DIRT	<input type="checkbox"/> LOW	<input type="checkbox"/> GAS	<input type="checkbox"/> DECLINING	<input type="checkbox"/> C. Ex Front	<input type="checkbox"/> H. VACANCY						
<input type="checkbox"/> SIDEWALKS	<input type="checkbox"/> ROLLING	<input type="checkbox"/> ELECTRIC	<input type="checkbox"/> OLD	<input type="checkbox"/> D. QUANTITY	<input type="checkbox"/> I. WATER FRONT						
<input type="checkbox"/> CURBS	<input type="checkbox"/> STANDARD	<input checked="" type="checkbox"/> STANDARD	<input type="checkbox"/> STANDARD	<input type="checkbox"/> E. SZ/SHAPE	<input type="checkbox"/> J. OTHER/CDU						
LAND COMPUTATIONS											
LAND TYPE	SIZE	M	RATE	C	INF					M	VALUE
F:Front	F120 D188				ST1730 DP111 ADJ1920		230,400	0			
TOTAL							230,400	0			

VALUATION SUMMARY								
VALUE YEAR	2023	2020	2020	2018	2017	2017	2017	
REASON FOR CHANGE	RAPP	RAPP	MISC	BOR	RAPP	MISC	MISC	
APPRAISED	LAND	230,400	230,200	213,100	213,100	213,100	213,100	
VALUE	IMPR	461,100	285,000	273,200	260,000	273,200	331,000	
	TOTAL	691,500	515,200	486,300	473,100	486,300	544,100	
ASSESSED	LAND	80,640	80,570	74,590	74,590	74,590	74,590	
VALUE	IMPR	161,390	99,750	95,620	91,000	95,620	115,850	
	TOTAL	242,030	180,320	170,210	165,590	170,210	190,440	

OCCUPANCY	EXTERIOR	FLOOR	AREA	CONST	VALUE
<input checked="" type="checkbox"/> SF <input type="checkbox"/> DU <input type="checkbox"/> TR	<input checked="" type="checkbox"/> WOOD	1	2278	BRK	272,490
<input type="checkbox"/> CONVERSION	<input type="checkbox"/> STUCCO	2ND	919	FR	49,310
<b>BUILDING TYPE</b>	<input type="checkbox"/> ALM/VYNL	+	0	FR	4,390
<input type="checkbox"/> MOBILE HOME	<input type="checkbox"/> CONC BLK				
<input type="checkbox"/> BI/TR LEVEL	<input type="checkbox"/> METAL				
<input type="checkbox"/> MOD/MAN	<input checked="" type="checkbox"/> BRICK				
<input type="checkbox"/>	<input checked="" type="checkbox"/> STONE				

ROOFING	ROOF TYPE
<input type="checkbox"/> METAL	<input checked="" type="checkbox"/> GABLE
<input type="checkbox"/> SLT/TLE	<input type="checkbox"/> HIP
<input checked="" type="checkbox"/> SHINGLES	<input type="checkbox"/> GAMBREL
<input type="checkbox"/> SHAKES	<input type="checkbox"/> MANSARD
<input type="checkbox"/> COMPOSITE	<input type="checkbox"/> FLAT

FLOORS	B	1	2	3	U
CONCRETE	<input type="checkbox"/>	<input checked="" type="checkbox"/>	<input type="checkbox"/>	<input type="checkbox"/>	<input type="checkbox"/>
WOOD	<input type="checkbox"/>	<input checked="" type="checkbox"/>	<input type="checkbox"/>	<input type="checkbox"/>	<input type="checkbox"/>
TILE/COMPO	<input type="checkbox"/>	<input type="checkbox"/>	<input checked="" type="checkbox"/>	<input type="checkbox"/>	<input type="checkbox"/>
CARPET	<input type="checkbox"/>	<input checked="" type="checkbox"/>	<input checked="" type="checkbox"/>	<input type="checkbox"/>	<input type="checkbox"/>
INT. FINISH	B	1	2	3	U
PLASTER/DW	<input type="checkbox"/>	<input checked="" type="checkbox"/>	<input checked="" type="checkbox"/>	<input type="checkbox"/>	<input type="checkbox"/>
PANELING	<input type="checkbox"/>	<input type="checkbox"/>	<input type="checkbox"/>	<input type="checkbox"/>	<input type="checkbox"/>
UNFINISHED	<input type="checkbox"/>	<input type="checkbox"/>	<input type="checkbox"/>	<input type="checkbox"/>	<input type="checkbox"/>
ACCOMMODATIONS					
# OF ROOMS		7	3		
BEDROOMS		2	2		
FIREPLACES		1			
HEAT & AC	B	1	2	3	U
NO HEAT	<input type="checkbox"/>	<input type="checkbox"/>	<input type="checkbox"/>	<input type="checkbox"/>	<input type="checkbox"/>
CTRL HEAT	<input type="checkbox"/>	<input checked="" type="checkbox"/>	<input checked="" type="checkbox"/>	<input type="checkbox"/>	<input type="checkbox"/>
HW/STEAM	<input type="checkbox"/>	<input type="checkbox"/>	<input type="checkbox"/>	<input type="checkbox"/>	<input type="checkbox"/>
ELECTRIC	<input type="checkbox"/>	<input type="checkbox"/>	<input type="checkbox"/>	<input type="checkbox"/>	<input type="checkbox"/>
HEAT PUMP	<input type="checkbox"/>	<input type="checkbox"/>	<input type="checkbox"/>	<input type="checkbox"/>	<input type="checkbox"/>
FLR/WALL	<input type="checkbox"/>	<input type="checkbox"/>	<input type="checkbox"/>	<input type="checkbox"/>	<input type="checkbox"/>
STVE/SPCE	<input type="checkbox"/>	<input type="checkbox"/>	<input type="checkbox"/>	<input type="checkbox"/>	<input type="checkbox"/>
GEOTHERMAL	<input type="checkbox"/>	<input type="checkbox"/>	<input type="checkbox"/>	<input type="checkbox"/>	<input type="checkbox"/>
OUTSIDE	<input type="checkbox"/>	<input type="checkbox"/>	<input type="checkbox"/>	<input type="checkbox"/>	<input type="checkbox"/>
CTRL A/C	<input type="checkbox"/>	<input checked="" type="checkbox"/>	<input checked="" type="checkbox"/>	<input type="checkbox"/>	<input type="checkbox"/>
PLUMBING		BASE <input checked="" type="checkbox"/>			
X FULL BATH		1	1		
X HALF BATH		1			
X FIXTURES		1			

<b>SUBTOTAL</b>			326,190
MULTI-FAMILY #	0		0
BUILDING TYPE	100%		0
BSMT FINISH	0 S.F.		0
FIREPLACE #	1		4,400
HEATING	0 S.F.		0
AIR COND	3,197 S.F.		5,280
PLUMBING #	9		10,890
GARAGES & CARPORTS			0
EXTRA FEATURES			28,730
<b>SUBTOTAL</b>			375,490
GRADE FACTOR			150 %
<b>UNADJUSTED VALUE</b>			563,240
FACTOR			100 %

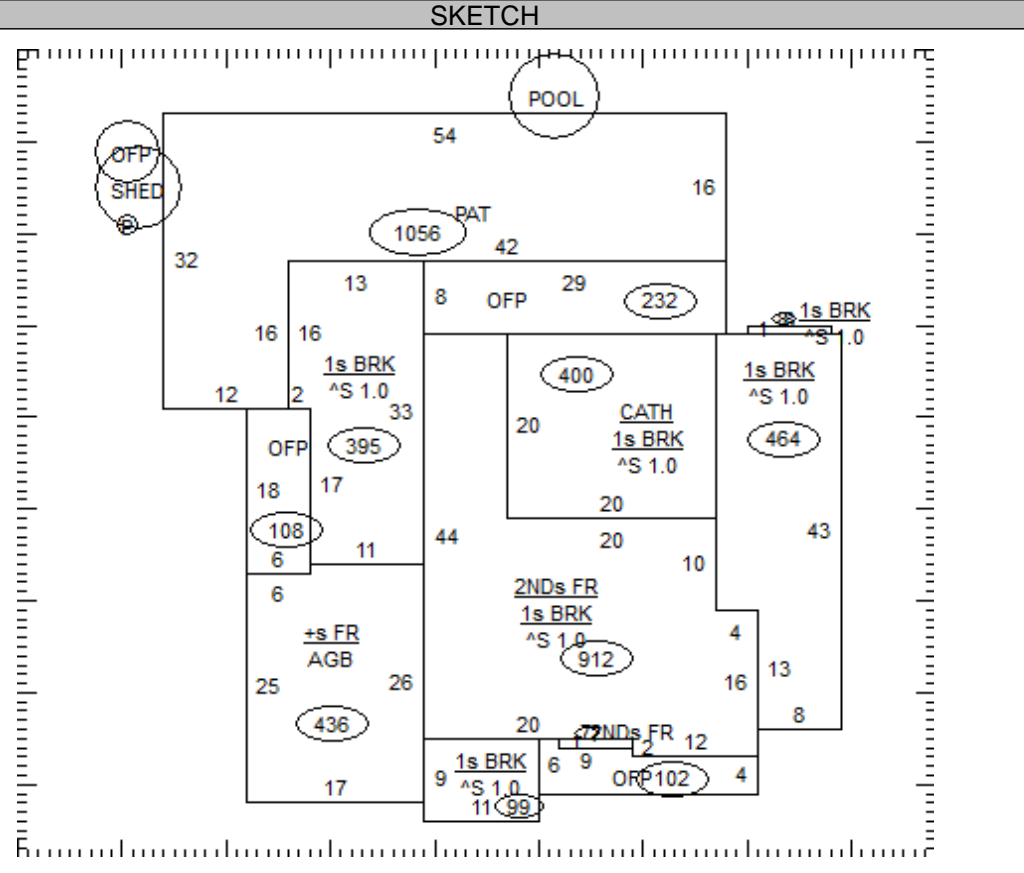

OCCUPANCY	ST.HT	SIZE	AREA	GRADE	PRICE	AGE	REMD	CND	UNADJ VAL	PHYS	PHYS VAL	FUNC	TRUE VAL
DWELLING	2	SK	3,197	A-		2002		A	563,240	19	456,220		447,100
1 Pool - Inground		16x35	560	C	37.50	2002		A	21,000	37	13,230		13,200
2 Shed	5	9x13	117	C		2002		A		37			0
3 Patio		10x12	120	C	4.05	2002		A	490	37	310		300
4 OFF		5x9	45	C	16.04	2002		A	720	37	450		500
5													
6													
7													
8													
9													
10													
11													

09-000200.0100 TOTAL 461,100

**COMMENTS**

Dwelling has an Economic Factor of 98% (Rollback Basis=\$677,500)