

DUBLIN TWP-ROCKFORD CORP / PARKWAY SD

02-17-201-003

Property Class: 510

Neighborhood
000802-TM50

Map: 9

Block:

Card: 21

Bk: Pg:

08-056400.0000

THOMPSON RANDALL K & BRYAN BONNIE L

THOMPSON RANDALL K & BRYAN BONNIE L

12120 US RT 127

VAN WERT, OH 45891

LEGAL INFORMATION

O L 19 PT

Acres:1.4730

	OWNERSHIP	ADDRESS	CITY	STATE	ZIP	DATE	AMOUNT	DEED:CONV#	JS	VALID
1	THOMPSON RANDALL K &	12120 US RT 127	VAN WERT	OH	45891	12/10/2020	95,000	SUC : 930	■	■
2	AGLER PATRICK N & MONICA	511 BRIDGE ST	ROCKFORD	OH	45882	05/21/2004	80,000	WDC : A : 0	□	■
3	PRICE RUBY C/O SHARON	PO BOX 9	WILLSHIRE	OH	45898	04/13/1999	0	: X : 0	□	□

X: Signature TTO LISTER: RK DATE: 10/07/2004 TIME: 03:00:20 PM LETTER LETTER REC'D GIS CODE

STREET/ROAD	TOPOGRAPHY	PU-UTILITIES-PR	NEIGHBORHOOD	INFLUENCE FACTORS	PROPERTY LOCATION
511 W BRIDGE ST, ROCKFORD					
COMMENT					
TY2022:Net Gen=\$1,489.52, Other Assessment=\$2.00 DE16 DESKTOP REVIEW CHG: COR PAT MSMNT, CHG OFF TO WDDK DE21 RMV HOMESTEAD CREDIT DE21 RMV OWN OCC CREDIT; DID NOT RET APP					

PAVED	LEVEL	WATER	IMPROVING	A. NO ROAD	F. RESTRICT
<input type="checkbox"/>	<input checked="" type="checkbox"/>	<input type="checkbox"/>	<input type="checkbox"/>	<input type="checkbox"/>	<input type="checkbox"/>
<input type="checkbox"/> GRAVEL	<input type="checkbox"/> HIGH	<input type="checkbox"/> SEWER	<input type="checkbox"/> STATIC	<input type="checkbox"/> B. TOPGRHY	<input type="checkbox"/> G. WOOD LT
<input type="checkbox"/> DIRT	<input type="checkbox"/> LOW	<input type="checkbox"/> GAS	<input type="checkbox"/> DECLINING	<input type="checkbox"/> C. Ex Front	<input type="checkbox"/> H. VACANCY
<input type="checkbox"/> SIDEWALKS	<input type="checkbox"/> ROLLING	<input type="checkbox"/> ELECTRIC	<input type="checkbox"/> OLD	<input type="checkbox"/> D. QUANTITY	<input type="checkbox"/> I. WATER FRONT
<input type="checkbox"/> CURBS	<input type="checkbox"/> STANDARD	<input checked="" type="checkbox"/> STANDARD	<input type="checkbox"/> STANDARD	<input type="checkbox"/> E. SZ/SHAPE	<input type="checkbox"/> J. OTHER/CDU

LAND COMPUTATIONS						
LAND TYPE	SIZE	M	RATE	C	INF	M VALUE C
HS:Home Site	AC:1	34070				34,100 0
SM:Small Acreage	AC:0.473	8500				4,000 0
Total Acres: 1.4730					TOTAL	38,100 0

VALUATION SUMMARY

VALUE YEAR	2023	2020	2017	2017
REASON FOR CHANGE	RAPP	RAPP	RAPP	MISC
APPRAISED VALUE	38,100	23,400	19,800	16,800
IMPR	91,600	71,400	56,500	51,900
TOTAL	129,700	94,800	76,300	68,700
ASSESSED VALUE	13,340	8,190	6,930	5,880
IMPR	32,060	24,990	19,780	18,170
TOTAL	45,400	33,180	26,710	24,050

OCCUPANCY		EXTERIOR		FLOOR	AREA	CONST	VALUE
<input checked="" type="checkbox"/> SF	<input type="checkbox"/> DU	<input type="checkbox"/> TR	<input type="checkbox"/> WOOD	1	960	FR	154,830
<input type="checkbox"/> CONVERSION			<input type="checkbox"/> STUCCO	.25	192	FR	28,240
BUILDING TYPE			<input checked="" type="checkbox"/> ALM/VYNL				
<input type="checkbox"/> MOBILE HOME			<input type="checkbox"/> CONC BLK				
<input type="checkbox"/> BI/TR LEVEL			<input type="checkbox"/> METAL				
<input type="checkbox"/> MOD/MAN			<input type="checkbox"/> BRICK				
<input type="checkbox"/>			<input type="checkbox"/> STONE				

ROOFING		ROOF TYPE	
<input type="checkbox"/> METAL			<input checked="" type="checkbox"/> GABLE
<input type="checkbox"/> SLT/TLE			<input type="checkbox"/> HIP
<input checked="" type="checkbox"/> SHINGLES			<input type="checkbox"/> GAMBREL
<input type="checkbox"/> SHAKES			<input type="checkbox"/> MANSARD
<input type="checkbox"/> COMPOSITE			<input type="checkbox"/> FLAT

FLOORS		B	1	2	3	U
CONCRETE	<input checked="" type="checkbox"/>	<input type="checkbox"/>	<input type="checkbox"/>	<input type="checkbox"/>	<input type="checkbox"/>	<input type="checkbox"/>
WOOD	<input type="checkbox"/>	<input checked="" type="checkbox"/>	<input checked="" type="checkbox"/>	<input type="checkbox"/>	<input type="checkbox"/>	<input type="checkbox"/>
TILE/COMPO	<input type="checkbox"/>	<input type="checkbox"/>	<input type="checkbox"/>	<input type="checkbox"/>	<input type="checkbox"/>	<input type="checkbox"/>
CARPET	<input type="checkbox"/>	<input checked="" type="checkbox"/>	<input checked="" type="checkbox"/>	<input type="checkbox"/>	<input type="checkbox"/>	<input type="checkbox"/>
INT. FINISH		B	1	2	3	U
PLASTER/DW	<input type="checkbox"/>	<input checked="" type="checkbox"/>	<input checked="" type="checkbox"/>	<input type="checkbox"/>	<input type="checkbox"/>	<input type="checkbox"/>
PANELING	<input type="checkbox"/>	<input type="checkbox"/>	<input type="checkbox"/>	<input type="checkbox"/>	<input type="checkbox"/>	<input type="checkbox"/>
UNFINISHED	<input checked="" type="checkbox"/>	<input type="checkbox"/>	<input type="checkbox"/>	<input type="checkbox"/>	<input type="checkbox"/>	<input type="checkbox"/>
ACCOMMODATIONS						
# OF ROOMS		4	2			
BEDROOMS		1	2			
FIREPLACES						
HEAT & AC		B	1	2	3	U
NO HEAT	<input type="checkbox"/>	<input type="checkbox"/>	<input type="checkbox"/>	<input type="checkbox"/>	<input type="checkbox"/>	<input type="checkbox"/>
CTRL HEAT	<input type="checkbox"/>	<input checked="" type="checkbox"/>	<input checked="" type="checkbox"/>	<input type="checkbox"/>	<input type="checkbox"/>	<input type="checkbox"/>
HW/STEAM	<input type="checkbox"/>	<input type="checkbox"/>	<input type="checkbox"/>	<input type="checkbox"/>	<input type="checkbox"/>	<input type="checkbox"/>
ELECTRIC	<input type="checkbox"/>	<input type="checkbox"/>	<input type="checkbox"/>	<input type="checkbox"/>	<input type="checkbox"/>	<input type="checkbox"/>
HEAT PUMP	<input type="checkbox"/>	<input type="checkbox"/>	<input type="checkbox"/>	<input type="checkbox"/>	<input type="checkbox"/>	<input type="checkbox"/>
FLR/WALL	<input type="checkbox"/>	<input type="checkbox"/>	<input type="checkbox"/>	<input type="checkbox"/>	<input type="checkbox"/>	<input type="checkbox"/>
STVE/SPCE	<input type="checkbox"/>	<input type="checkbox"/>	<input type="checkbox"/>	<input type="checkbox"/>	<input type="checkbox"/>	<input type="checkbox"/>
GEO THERMAL	<input type="checkbox"/>	<input type="checkbox"/>	<input type="checkbox"/>	<input type="checkbox"/>	<input type="checkbox"/>	<input type="checkbox"/>
OUTSIDE	<input type="checkbox"/>	<input type="checkbox"/>	<input type="checkbox"/>	<input type="checkbox"/>	<input type="checkbox"/>	<input type="checkbox"/>
CTRL A/C	<input type="checkbox"/>	<input checked="" type="checkbox"/>	<input type="checkbox"/>	<input type="checkbox"/>	<input type="checkbox"/>	<input type="checkbox"/>
PLUMBING		BASE		<input checked="" type="checkbox"/>		
X FULL BATH						
X HALF BATH						
X FIXTURES						

BSMT	768		10,980
SUBTOTAL			194,050
MULTI-FAMILY #	0		0
BUILDING TYPE	100%		0
BSMT FINISH	0 S.F.		0
FIREPLACE #	0		0
HEATING	0 S.F.		0
AIR COND	960 S.F.		1,580
PLUMBING #	0		0
GARAGES & CARPORTS			23,500
EXTRA FEATURES			900
SUBTOTAL			220,030
GRADE FACTOR			100 %
UNADJUSTED VALUE			220,030
FACTOR			100 %

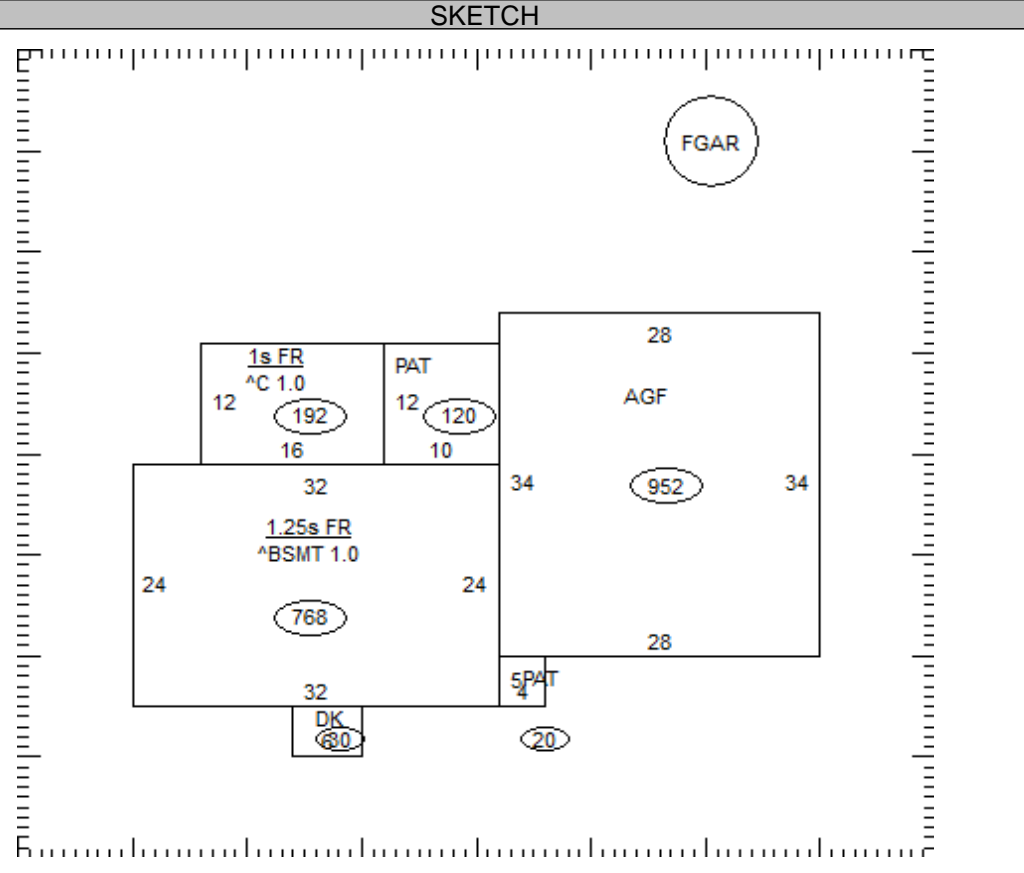

OCCUPANCY	ST.HT	SIZE	AREA	GRADE	PRICE	AGE	REMD	CND	UNADJ VAL	PHYS	PHYS VAL	FUNC	TRUE VAL
DWELLING	1.25	SK	1,152	C		1952		A	220,030	45	121,020		90,800
1 Gar - Frame		22x32	704	C	23.70	1952		A	16,680	95	830		800
2													
3													
4													
5													
6													
7													
8													
9													
10													
11													

08-056400.0000	TOTAL	91,600
----------------	--------------	--------

COMMENTS

Dwelling has an Economic Factor of 75%