







OCCUPANCY	EXTERIOR	FLOOR	AREA	CONST	VALUE
<input type="checkbox"/> SF <input type="checkbox"/> DU <input type="checkbox"/> TR	<input type="checkbox"/> WOOD				
<input type="checkbox"/> CONVERSION	<input type="checkbox"/> STUCCO				
<b>BUILDING TYPE</b>	<input type="checkbox"/> ALM/VYNL				
<input type="checkbox"/> MOBILE HOME	<input type="checkbox"/> CONC BLK				
<input type="checkbox"/> BI/TR LEVEL	<input type="checkbox"/> METAL				
<input type="checkbox"/> MOD/MAN	<input type="checkbox"/> BRICK				
<input type="checkbox"/>	<input type="checkbox"/> STONE				
ROOFING	ROOF TYPE				
<input type="checkbox"/> METAL	<input type="checkbox"/> GABLE				
<input type="checkbox"/> SLT/TLE	<input type="checkbox"/> HIP				
<input type="checkbox"/> SHINGLES	<input type="checkbox"/> GAMBREL				
<input type="checkbox"/> SHAKES	<input type="checkbox"/> MANSARD				
<input type="checkbox"/> COMPOSITE	<input type="checkbox"/> FLAT				

<b>SUBTOTAL</b>					0
MULTI-FAMILY #	0				0
BUILDING TYPE	000%				0
BSMT FINISH	0 S.F.				0
FIREPLACE #	0				0
HEATING	0 S.F.				0
AIR COND	0 S.F.				0
PLUMBING #	0				0
GARAGES & CARPORTS					0
EXTRA FEATURES					0
<b>SUBTOTAL</b>					0
GRADE FACTOR					%
<b>UNADJUSTED VALUE</b>					0
FACTOR					%

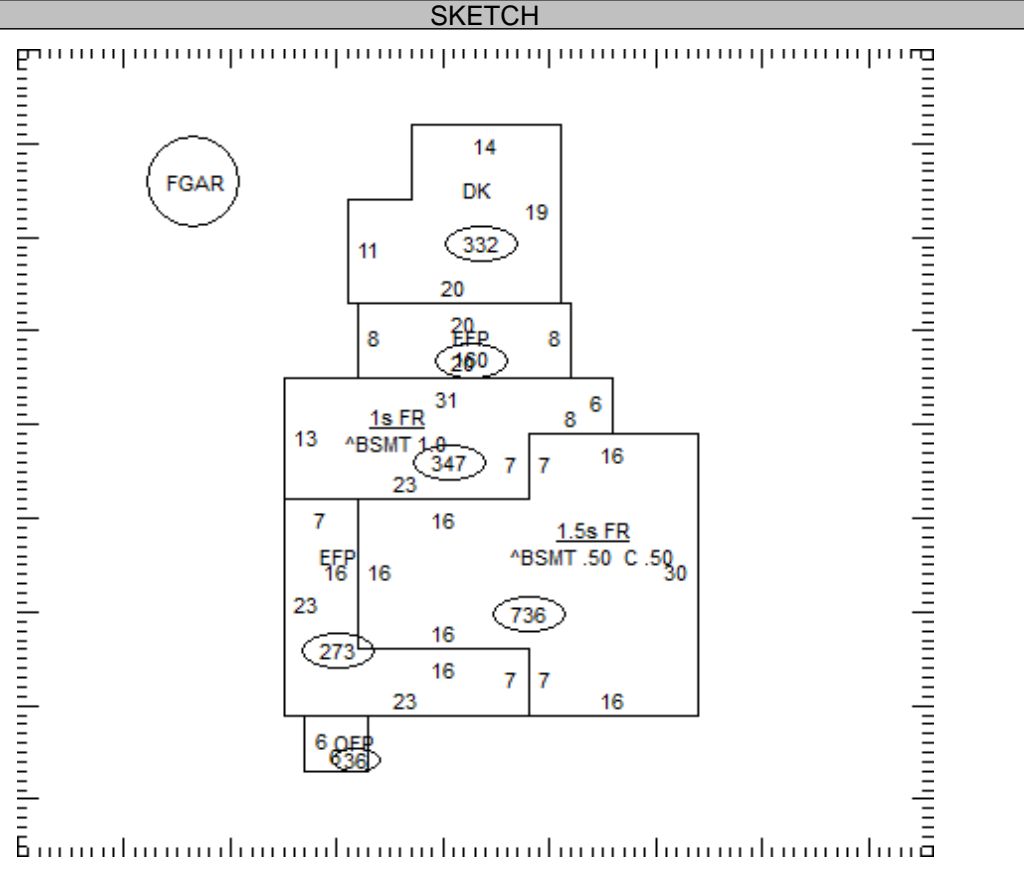

OCCUPANCY	ST.HT	SIZE	AREA	GRADE	PRICE	AGE	REMD	CND	UNADJ VAL	PHYS	PHYS VAL	FUNC	TRUE VAL
DWELLING		SK											
1													
2													
3													
4													
5													
6													
7													
8													
9													
10													
11													

08-036600.0000

TOTAL 0

COMMENTS