

DUBLIN TWP-ROCKFORD CORP / PARKWAY SD

02-16-307-002

Property Class: 510

Neighborhood

000802-TM50

Map: 09

Block:

Card: 198

Bk: Pg:

08-014100.0000

MAHARG PROPERTIES LTD

MAHARG PROPERTIES LTD

3726 MONROE RD

CELINA, OH 45822

LEGAL INFORMATION

EHRET ADDITION

LOT#: 85

	OWNERSHIP	ADDRESS	CITY	STATE	ZIP	DATE	AMOUNT	DEED:CONV#	JS	VALID
1	MAHARG PROPERTIES LTD	3726 MONROE RD	CELINA	OH	45822	07/17/2019	38,500	WDC : 490	<input type="checkbox"/>	<input checked="" type="checkbox"/>
2	ADAMS MARY LOU	8169 DEEP CUT RD	MENDON	OH	45862	12/15/2004	0	QCE : X : 0	<input type="checkbox"/>	<input type="checkbox"/>
3	ADAMS DONALD W & MARY	8169 DEEP CUT RD	MENDON	OH	45862	03/01/2002	55,000	: A : 0	<input type="checkbox"/>	<input checked="" type="checkbox"/>

X: TTO LISTER: HK DATE: 06/26/2023 TIME: 12:00:00 AM LETTER LETTER REC'D GIS CODE

STREET/ROAD TOPOGRAPHY PU-UTILITIES-PR NEIGHBORHOOD INFLUENCE FACTORS PROPERTY LOCATION

PAVED LEVEL WATER IMPROVING A. NO ROAD F. RESTRICT 306 S MAIN ST, ROCKFORD
 GRAVEL HIGH SEWER STATIC B. TOPGRHY G. WOOD LT COMMENT
 DIRT LOW GAS DECLINING C. Ex Front H. VACANCY TY2022:Net Gen=\$1,305.92, Other
 SIDEWALKS ROLLING ELECTRIC OLD D. QUANTITY I. WATER FRONT Assessment=\$2.00
 CURBS STANDARD STANDARD E. SZ/SHAPE J. OTHER/CDU DE16 DESKTOP REVIEW CHGS: CHG BW TO
 OH, ADD 2S OH
 DE08 TTO/RMV'D AC
 DE20 RMV OWN OCC
 DE23 DWLG VAC, CHG COND

LAND COMPUTATIONS

LAND TYPE	SIZE	M	RATE	C	INF	M	VALUE	C
F:Front	F66 D132	ST325	DP94	ADJ306		20,200	0	
						TOTAL	20,200	0

VALUATION SUMMARY

VALUE YEAR	2023	2020	2017
REASON FOR CHANGE	NC	RAPP	RAPP
APPRAISED VALUE	20,200	15,300	13,000
	IMPR	67,800	54,000
	TOTAL	83,100	67,000
ASSESSED VALUE	7,070	5,360	4,550
	IMPR	23,730	18,900
	TOTAL	29,090	23,450

OCCUPANCY		EXTERIOR		FLOOR	AREA	CONST	VALUE
<input checked="" type="checkbox"/> SF	<input type="checkbox"/> DU	<input type="checkbox"/> TR	<input checked="" type="checkbox"/> WOOD	1	1150	FR	173,270
<input type="checkbox"/> CONVERSION			<input type="checkbox"/> STUCCO	2ND	694	FR	50,190
BUILDING TYPE							
<input type="checkbox"/> MOBILE HOME			<input type="checkbox"/> ALM/VYNL				
<input type="checkbox"/> BI/TR LEVEL			<input type="checkbox"/> CONC BLK				
<input type="checkbox"/> MOD/MAN			<input type="checkbox"/> METAL				
<input type="checkbox"/>			<input type="checkbox"/> BRICK				
			<input type="checkbox"/> STONE				

ROOFING		ROOF TYPE	
<input type="checkbox"/> METAL	<input checked="" type="checkbox"/> GABLE		
<input type="checkbox"/> SLT/TLE	<input type="checkbox"/> HIP		
<input checked="" type="checkbox"/> SHINGLES	<input type="checkbox"/> GAMBREL		
<input type="checkbox"/> SHAKES	<input type="checkbox"/> MANSARD		
<input type="checkbox"/> COMPOSITE	<input type="checkbox"/> FLAT		

FLOORS		B	1	2	3	U
CONCRETE	<input checked="" type="checkbox"/>	<input type="checkbox"/>	<input type="checkbox"/>	<input type="checkbox"/>	<input type="checkbox"/>	<input type="checkbox"/>
WOOD	<input type="checkbox"/>	<input type="checkbox"/>	<input type="checkbox"/>	<input type="checkbox"/>	<input type="checkbox"/>	<input type="checkbox"/>
TILE/COMPO	<input type="checkbox"/>	<input checked="" type="checkbox"/>	<input type="checkbox"/>	<input type="checkbox"/>	<input type="checkbox"/>	<input type="checkbox"/>
CARPET	<input type="checkbox"/>	<input checked="" type="checkbox"/>	<input checked="" type="checkbox"/>	<input type="checkbox"/>	<input type="checkbox"/>	<input type="checkbox"/>
INT. FINISH		B	1	2	3	U
PLASTER/DW	<input type="checkbox"/>	<input checked="" type="checkbox"/>	<input checked="" type="checkbox"/>	<input type="checkbox"/>	<input type="checkbox"/>	<input type="checkbox"/>
PANELING	<input type="checkbox"/>	<input type="checkbox"/>	<input type="checkbox"/>	<input type="checkbox"/>	<input type="checkbox"/>	<input type="checkbox"/>
UNFINISHED	<input checked="" type="checkbox"/>	<input type="checkbox"/>	<input type="checkbox"/>	<input type="checkbox"/>	<input type="checkbox"/>	<input type="checkbox"/>
ACCOMMODATIONS						
# OF ROOMS		4	3			
BEDROOMS			3			
FIREPLACES						
HEAT & AC		B	1	2	3	U
NO HEAT	<input type="checkbox"/>	<input type="checkbox"/>	<input type="checkbox"/>	<input type="checkbox"/>	<input type="checkbox"/>	<input type="checkbox"/>
CTRL HEAT	<input type="checkbox"/>	<input checked="" type="checkbox"/>	<input checked="" type="checkbox"/>	<input type="checkbox"/>	<input type="checkbox"/>	<input type="checkbox"/>
HW/STEAM	<input type="checkbox"/>	<input type="checkbox"/>	<input type="checkbox"/>	<input type="checkbox"/>	<input type="checkbox"/>	<input type="checkbox"/>
ELECTRIC	<input type="checkbox"/>	<input type="checkbox"/>	<input type="checkbox"/>	<input type="checkbox"/>	<input type="checkbox"/>	<input type="checkbox"/>
HEAT PUMP	<input type="checkbox"/>	<input type="checkbox"/>	<input type="checkbox"/>	<input type="checkbox"/>	<input type="checkbox"/>	<input type="checkbox"/>
FLR/WALL	<input type="checkbox"/>	<input type="checkbox"/>	<input type="checkbox"/>	<input type="checkbox"/>	<input type="checkbox"/>	<input type="checkbox"/>
STVE/SPCE	<input type="checkbox"/>	<input type="checkbox"/>	<input type="checkbox"/>	<input type="checkbox"/>	<input type="checkbox"/>	<input type="checkbox"/>
GEOTHERMAL	<input type="checkbox"/>	<input type="checkbox"/>	<input type="checkbox"/>	<input type="checkbox"/>	<input type="checkbox"/>	<input type="checkbox"/>
OUTSIDE	<input type="checkbox"/>	<input type="checkbox"/>	<input type="checkbox"/>	<input type="checkbox"/>	<input type="checkbox"/>	<input type="checkbox"/>
CTRL A/C	<input type="checkbox"/>	<input type="checkbox"/>	<input type="checkbox"/>	<input type="checkbox"/>	<input type="checkbox"/>	<input type="checkbox"/>
PLUMBING		BASE <input checked="" type="checkbox"/>				
X FULL BATH						
X HALF BATH						
X FIXTURES						

BSMT	694		9,920
SUBTOTAL			233,380
MULTI-FAMILY #	0		0
BUILDING TYPE	100%		0
BSMT FINISH	0 S.F.		0
FIREPLACE #	0		0
HEATING	0 S.F.		0
AIR COND	0 S.F.		0
PLUMBING #	0		0
GARAGES & CARPORTS			0
EXTRA FEATURES			7,600
SUBTOTAL			240,980
GRADE FACTOR			100 %
UNADJUSTED VALUE			240,980
FACTOR			100 %

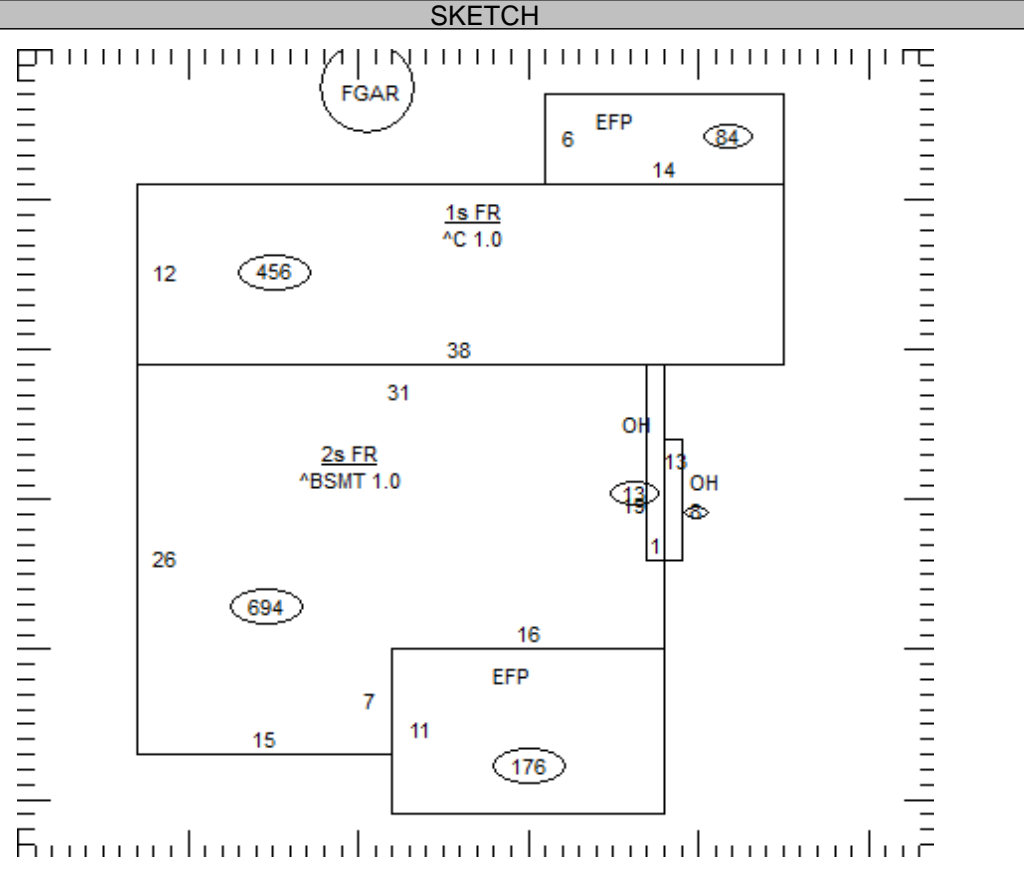

OCCUPANCY	ST.HT	SIZE	AREA	GRADE	PRICE	AGE	REMD	CND	UNADJ VAL	PHYS	PHYS VAL	FUNC	TRUE VAL
DWELLING	2	SK	1,844	C		1900		G	240,980	40	144,590		108,400
1 Gar - Frame		24x26	624	C	23.70	1974		A	14,790	80	2,960		3,000
2													
3													
4													
5													
6													
7													
8													
9													
10													
11													

08-014100.0000 TOTAL 111,400

COMMENTS

2022 NEW WINDOWS, ROOF, SIDING
 Dwelling has an Economic Factor of 75%