

DUBLIN TWP / PARKWAY SD

02-36-400-002

07-081500.0000

**KELLER ADAM**  
KELLER ADAM  
10020 US RTE 127  
MENDON, OH 45862

**LEGAL INFORMATION**

SW COR SE

RTS: 002-04-36  
Acres:1.4800

	OWNERSHIP	ADDRESS	CITY	STATE	ZIP	DATE	AMOUNT	DEED:CONV#	JS	VALID
1	KELLER ADAM	10020 US RTE 127	MENDON	OH	45862	01/04/2019	164,500	WDC : 4	<input type="checkbox"/>	<input checked="" type="checkbox"/>
2	DONOVAN MICHAEL L &	10020 US RTE 127	MENDON	OH	45862	08/30/2013	90,000	WDC : 576	<input type="checkbox"/>	<input type="checkbox"/>
3	DONOVAN JAMET M	10260 HALFHILL RD	MENDON	OH	45862	01/27/2009	0	QCE : X : 0	<input type="checkbox"/>	<input type="checkbox"/>

X:  TTO LISTER: DATE: 07/15/2013 TIME: 12:00:00 AM  LETTER  LETTER REC'D GIS CODE

STREET/ROAD TOPOGRAPHY PU-UTILITIES-PR NEIGHBORHOOD INFLUENCE FACTORS PROPERTY LOCATION

- PAVED  LEVEL  WATER  IMPROVING  A. NO ROAD  F. RESTRICT
- GRAVEL  HIGH  SEWER  STATIC  B. TOPGRHY  G. WOOD LT
- DIRT  LOW  GAS  DECLINING  C. Ex Front  H. VACANCY
- SIDEWALKS  ROLLING  ELECTRIC  OLD  D. QUANTITY  I. WATER FRONT
- CURBS  STANDARD  STANDARD  E. SZ/SHAPE  J. OTHER/CDU

10020 US RT 127, MENDON  
**COMMENT**  
 TY2022:Net Gen=\$1,839.16, Other  
 Assessment=\$102.30  
 DE17 DESKTOP RVW CHGS: COR WDDK AREA,  
 ADD OFF  
 DE09 PER DATA MAILER ADDED X-FIXTURE  
 DE20 RMV OWN OCC; DIDN'T RET APP

**LAND COMPUTATIONS**

LAND TYPE	SIZE	M	RATE	C	INF	M	VALUE	C
HS:Home Site	AC:1	17660				17,700	0	
SM:Small Acreage	AC:0.48	8500				4,100	0	
Total Acres: 1.4800					TOTAL	21,800	0	

**VALUATION SUMMARY**

VALUE YEAR	2023	2020	2017	2017				
REASON FOR CHANGE	RAPP	RAPP	RAPP	MISC				
APPRAISED	21,800	21,300	19,900	16,900				
VALUE	LAND							
	IMPR							
	TOTAL							
ASSESSED	7,630	7,460	6,970	5,920				
VALUE	LAND							
	IMPR							
	TOTAL							

OCCUPANCY	EXTERIOR	FLOOR	AREA	CONST	VALUE										
<input checked="" type="checkbox"/> SF <input type="checkbox"/> DU <input type="checkbox"/> TR	<input checked="" type="checkbox"/> WOOD	1	1244	FR	184,170										
<input type="checkbox"/> CONVERSION	<input type="checkbox"/> STUCCO	.25	49	FR	6,620										
<b>BUILDING TYPE</b>	<input type="checkbox"/> ALM/VYNL	2ND	684	FR	48,610										
<input type="checkbox"/> MOBILE HOME	<input type="checkbox"/> CONC BLK														
<input type="checkbox"/> BI/TR LEVEL	<input type="checkbox"/> METAL														
<input type="checkbox"/> MOD/MAN	<input type="checkbox"/> BRICK														
<input type="checkbox"/> _____	<input type="checkbox"/> STONE														
<b>ROOFING</b>	<b>ROOF TYPE</b>														
<input type="checkbox"/> METAL	<input checked="" type="checkbox"/> GABLE														
<input checked="" type="checkbox"/> SLT/TLE	<input type="checkbox"/> HIP														
<input type="checkbox"/> SHINGLES	<input type="checkbox"/> GAMBREL														
<input type="checkbox"/> SHAKES	<input type="checkbox"/> MANSARD														
<input type="checkbox"/> COMPOSITE	<input type="checkbox"/> FLAT														
<b>FLOORS</b>	<b>B 1 2 3 U</b>	BSMT	684		9,780										
CONCRETE	<input checked="" type="checkbox"/> <input type="checkbox"/> <input type="checkbox"/> <input type="checkbox"/> <input type="checkbox"/>	<b>SUBTOTAL</b>			249,180										
WOOD	<input type="checkbox"/> <input type="checkbox"/> <input type="checkbox"/> <input type="checkbox"/> <input type="checkbox"/>	MULTI-FAMILY #	0		0										
TILE/COMPO	<input type="checkbox"/> <input type="checkbox"/> <input type="checkbox"/> <input type="checkbox"/> <input type="checkbox"/>	BUILDING TYPE	100%		0										
CARPET	<input type="checkbox"/> <input checked="" type="checkbox"/> <input checked="" type="checkbox"/> <input checked="" type="checkbox"/> <input type="checkbox"/>	BSMT FINISH	0 S.F.		0										
<b>INT. FINISH</b>	<b>B 1 2 3 U</b>	FIREPLACE #	1		4,400										
PLASTER/DW	<input type="checkbox"/> <input checked="" type="checkbox"/> <input checked="" type="checkbox"/> <input checked="" type="checkbox"/> <input type="checkbox"/>	HEATING	0 S.F.		0										
PANELING	<input type="checkbox"/> <input type="checkbox"/> <input type="checkbox"/> <input type="checkbox"/> <input type="checkbox"/>	AIR COND	0 S.F.		0										
UNFINISHED	<input checked="" type="checkbox"/> <input type="checkbox"/> <input type="checkbox"/> <input type="checkbox"/> <input type="checkbox"/>	PLUMBING #	4		4,840										
<b>ACCOMMODATIONS</b>		GARAGES & CARPORTS			0										
# OF ROOMS		EXTRA FEATURES			8,700										
BEDROOMS		<b>SUBTOTAL</b>			267,120										
FIREPLACES		GRADE FACTOR			100 %										
HEAT & AC		<b>UNADJUSTED VALUE</b>			267,120										
NO HEAT	<input type="checkbox"/> <input type="checkbox"/> <input type="checkbox"/> <input type="checkbox"/> <input type="checkbox"/>	FACTOR			100 %										
CTRL HEAT	<input type="checkbox"/> <input checked="" type="checkbox"/> <input checked="" type="checkbox"/> <input checked="" type="checkbox"/> <input type="checkbox"/>	<b>OCCUPANCY</b>	<b>ST.HT</b>	<b>SIZE</b>	<b>AREA</b>	<b>GRADE</b>	<b>PRICE</b>	<b>AGE</b>	<b>REMD</b>	<b>CND</b>	<b>UNADJ VAL</b>	<b>PHYS</b>	<b>PHYS VAL</b>	<b>FUNC</b>	<b>TRUE VAL</b>
HW/STEAM	<input type="checkbox"/> <input type="checkbox"/> <input type="checkbox"/> <input type="checkbox"/> <input type="checkbox"/>	DWELLING	2	SK	1,977	C		1900		A	267,120	45	146,920		160,100
ELECTRIC	<input type="checkbox"/> <input type="checkbox"/> <input type="checkbox"/> <input type="checkbox"/> <input type="checkbox"/>	1 Gar - Frame	1	28x36	1,008	C	23.70	1993		A	23,890	47	12,660		12,700
HEAT PUMP	<input type="checkbox"/> <input type="checkbox"/> <input type="checkbox"/> <input type="checkbox"/> <input type="checkbox"/>	2													
FLR/WALL	<input type="checkbox"/> <input type="checkbox"/> <input type="checkbox"/> <input type="checkbox"/> <input type="checkbox"/>	3													
STVE/SPCE	<input type="checkbox"/> <input type="checkbox"/> <input type="checkbox"/> <input type="checkbox"/> <input type="checkbox"/>	4													
GEO THERMAL	<input type="checkbox"/> <input type="checkbox"/> <input type="checkbox"/> <input type="checkbox"/> <input type="checkbox"/>	5													
OUTSIDE	<input type="checkbox"/> <input type="checkbox"/> <input type="checkbox"/> <input type="checkbox"/> <input type="checkbox"/>	6													
CTRL A/C	<input type="checkbox"/> <input type="checkbox"/> <input type="checkbox"/> <input type="checkbox"/> <input type="checkbox"/>	7													
<b>PLUMBING</b>	<b>BASE</b> <input checked="" type="checkbox"/>	8													
X FULL BATH		9													
X HALF BATH		10													
X FIXTURES		11													

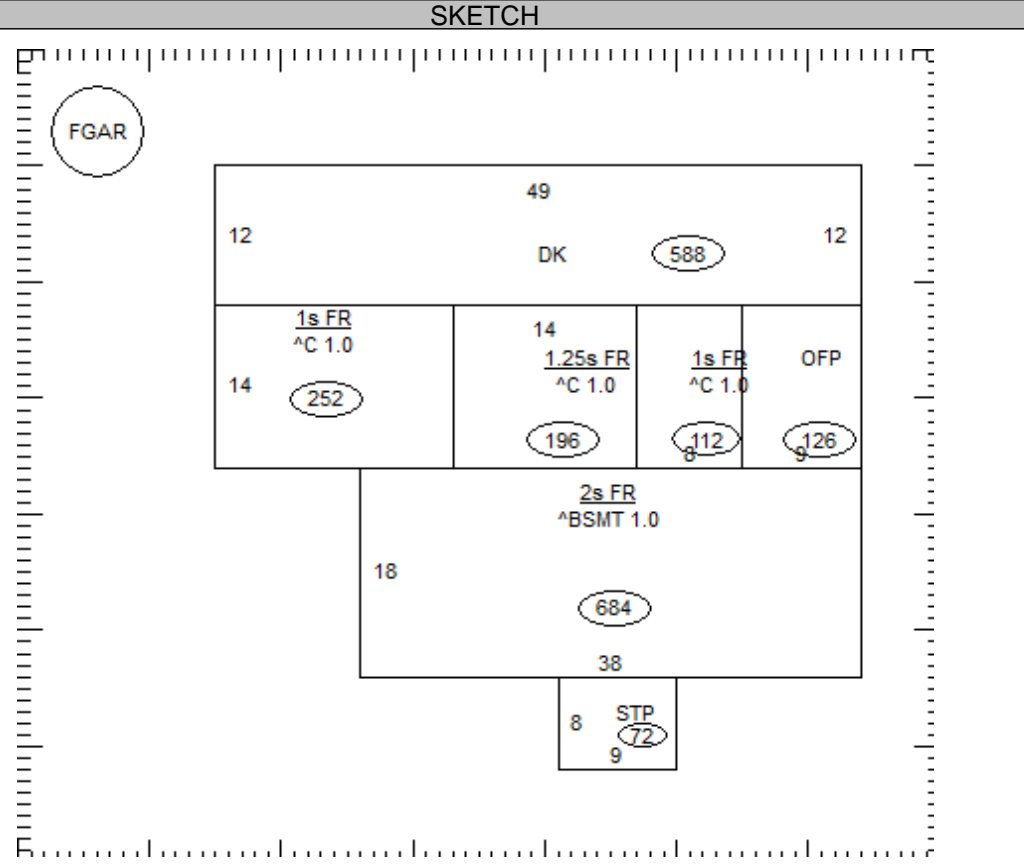

07-081500.0000

TOTAL 172,800

COMMENTS

Dwelling has an Economic Factor of 109%

DUBLIN TWP / PARKWAY SD

02-36-400-002

Property Class: 510

Neighborhood

009075-R150

Map: 20

Block:

Card: 09

Bk: Pg:

07-081500.0000

LEGAL INFORMATION

SW COR SE

RTS: 002-04-36

Acres:1.4800

KELLER ADAM  
KELLER ADAM  
10020 US RTE 127  
MENDON, OH 45862

	OWNERSHIP	ADDRESS	CITY	STATE	ZIP	DATE	AMOUNT	DEED:CONV#	JS	VALID
1	DONOVAN DANIEL D & JAMET	10260 HALF HILL RD	MENDON	OH	45862	08/17/1988	0	: X : 0	<input type="checkbox"/>	<input type="checkbox"/>
2							0	0	<input type="checkbox"/>	<input type="checkbox"/>
3							0	0	<input type="checkbox"/>	<input type="checkbox"/>

X:  TTO LISTER: DATE: 07/15/2013 TIME: 12:00:00 AM  LETTER  LETTER REC'D GIS CODE

STREET/ROAD	TOPOGRAPHY	PU-UTILITIES-PR	NEIGHBORHOOD	INFLUENCE FACTORS	PROPERTY LOCATION	
<input checked="" type="checkbox"/> PAVED <input type="checkbox"/> GRAVEL <input type="checkbox"/> DIRT <input type="checkbox"/> SIDEWALKS <input type="checkbox"/> CURBS	<input checked="" type="checkbox"/> LEVEL <input type="checkbox"/> HIGH <input type="checkbox"/> LOW <input type="checkbox"/> ROLLING <input type="checkbox"/> STANDARD	<input type="checkbox"/> WATER <input type="checkbox"/> SEWER <input type="checkbox"/> GAS <input checked="" type="checkbox"/> ELECTRIC <input type="checkbox"/> STANDARD	<input type="checkbox"/> IMPROVING <input checked="" type="checkbox"/> STATIC <input type="checkbox"/> DECLINING <input type="checkbox"/> OLD <input type="checkbox"/> STANDARD	<input type="checkbox"/> A. NO ROAD <input type="checkbox"/> B. TOPGRHY <input type="checkbox"/> C. Ex Front <input type="checkbox"/> D. QUANTITY <input type="checkbox"/> E. SZ/SHAPE	<input type="checkbox"/> F. RESTRICT <input type="checkbox"/> G. WOOD LT <input type="checkbox"/> H. VACANCY <input type="checkbox"/> I. WATER FRONT <input type="checkbox"/> J. OTHER/CDU	10020 US RT 127, MENDON COMMENT

LAND COMPUTATIONS

LAND TYPE	SIZE	M	RATE	C	INF	M	VALUE	C
Total Acres: 1.4800					TOTAL		21,800	0

VALUATION SUMMARY

VALUE YEAR	REASON FOR CHANGE	APPRaised	IMPR	TOTAL	ASSESSED	IMPR	TOTAL

OCCUPANCY	EXTERIOR	FLOOR	AREA	CONST	VALUE
<input type="checkbox"/> SF <input type="checkbox"/> DU <input type="checkbox"/> TR	<input type="checkbox"/> WOOD				
<input type="checkbox"/> CONVERSION	<input type="checkbox"/> STUCCO				
<b>BUILDING TYPE</b>	<input type="checkbox"/> ALM/VYNL				
<input type="checkbox"/> MOBILE HOME	<input type="checkbox"/> CONC BLK				
<input type="checkbox"/> BI/TR LEVEL	<input type="checkbox"/> METAL				
<input type="checkbox"/> MOD/MAN	<input type="checkbox"/> BRICK				
<input type="checkbox"/>	<input type="checkbox"/> STONE				
ROOFING	ROOF TYPE				
<input type="checkbox"/> METAL	<input type="checkbox"/> GABLE				
<input type="checkbox"/> SLT/TLE	<input type="checkbox"/> HIP				
<input type="checkbox"/> SHINGLES	<input type="checkbox"/> GAMBREL				
<input type="checkbox"/> SHAKES	<input type="checkbox"/> MANSARD				
<input type="checkbox"/> COMPOSITE	<input type="checkbox"/> FLAT				

FLOORS	B	1	2	3	U	SUBTOTAL	0
CONCRETE	<input type="checkbox"/>	<input type="checkbox"/>	<input type="checkbox"/>	<input type="checkbox"/>	<input type="checkbox"/>	MULTI-FAMILY #	0
WOOD	<input type="checkbox"/>	<input type="checkbox"/>	<input type="checkbox"/>	<input type="checkbox"/>	<input type="checkbox"/>	BUILDING TYPE	000%
TILE/COMPO	<input type="checkbox"/>	<input type="checkbox"/>	<input type="checkbox"/>	<input type="checkbox"/>	<input type="checkbox"/>	BSMT FINISH	0 S.F.
CARPET	<input type="checkbox"/>	<input type="checkbox"/>	<input type="checkbox"/>	<input type="checkbox"/>	<input type="checkbox"/>	FIREPLACE #	0
INT. FINISH	B	1	2	3	U	HEATING	0 S.F.
PLASTER/DW	<input type="checkbox"/>	<input type="checkbox"/>	<input type="checkbox"/>	<input type="checkbox"/>	<input type="checkbox"/>	AIR COND	0 S.F.
PANELING	<input type="checkbox"/>	<input type="checkbox"/>	<input type="checkbox"/>	<input type="checkbox"/>	<input type="checkbox"/>	PLUMBING #	0
UNFINISHED	<input type="checkbox"/>	<input type="checkbox"/>	<input type="checkbox"/>	<input type="checkbox"/>	<input type="checkbox"/>	GARAGES & CARPORTS	0
ACCOMMODATIONS						EXTRA FEATURES	0
# OF ROOMS						SUBTOTAL	0
BEDROOMS						GRADE FACTOR	%
FIREPLACES						UNADJUSTED VALUE	0
HEAT & AC	B	1	2	3	U	FACTOR	%
NO HEAT	<input type="checkbox"/>	<input type="checkbox"/>	<input type="checkbox"/>	<input type="checkbox"/>	<input type="checkbox"/>		
CTRL HEAT	<input type="checkbox"/>	<input type="checkbox"/>	<input type="checkbox"/>	<input type="checkbox"/>	<input type="checkbox"/>		
HW/STEAM	<input type="checkbox"/>	<input type="checkbox"/>	<input type="checkbox"/>	<input type="checkbox"/>	<input type="checkbox"/>		
ELECTRIC	<input type="checkbox"/>	<input type="checkbox"/>	<input type="checkbox"/>	<input type="checkbox"/>	<input type="checkbox"/>		
HEAT PUMP	<input type="checkbox"/>	<input type="checkbox"/>	<input type="checkbox"/>	<input type="checkbox"/>	<input type="checkbox"/>		
FLR/WALL	<input type="checkbox"/>	<input type="checkbox"/>	<input type="checkbox"/>	<input type="checkbox"/>	<input type="checkbox"/>		
STVE/SPCE	<input type="checkbox"/>	<input type="checkbox"/>	<input type="checkbox"/>	<input type="checkbox"/>	<input type="checkbox"/>		
GEO THERMAL	<input type="checkbox"/>	<input type="checkbox"/>	<input type="checkbox"/>	<input type="checkbox"/>	<input type="checkbox"/>		
OUTSIDE	<input type="checkbox"/>	<input type="checkbox"/>	<input type="checkbox"/>	<input type="checkbox"/>	<input type="checkbox"/>		
CTRL A/C	<input type="checkbox"/>	<input type="checkbox"/>	<input type="checkbox"/>	<input type="checkbox"/>	<input type="checkbox"/>		
PLUMBING							
X FULL BATH							
X HALF BATH							
X FIXTURES							

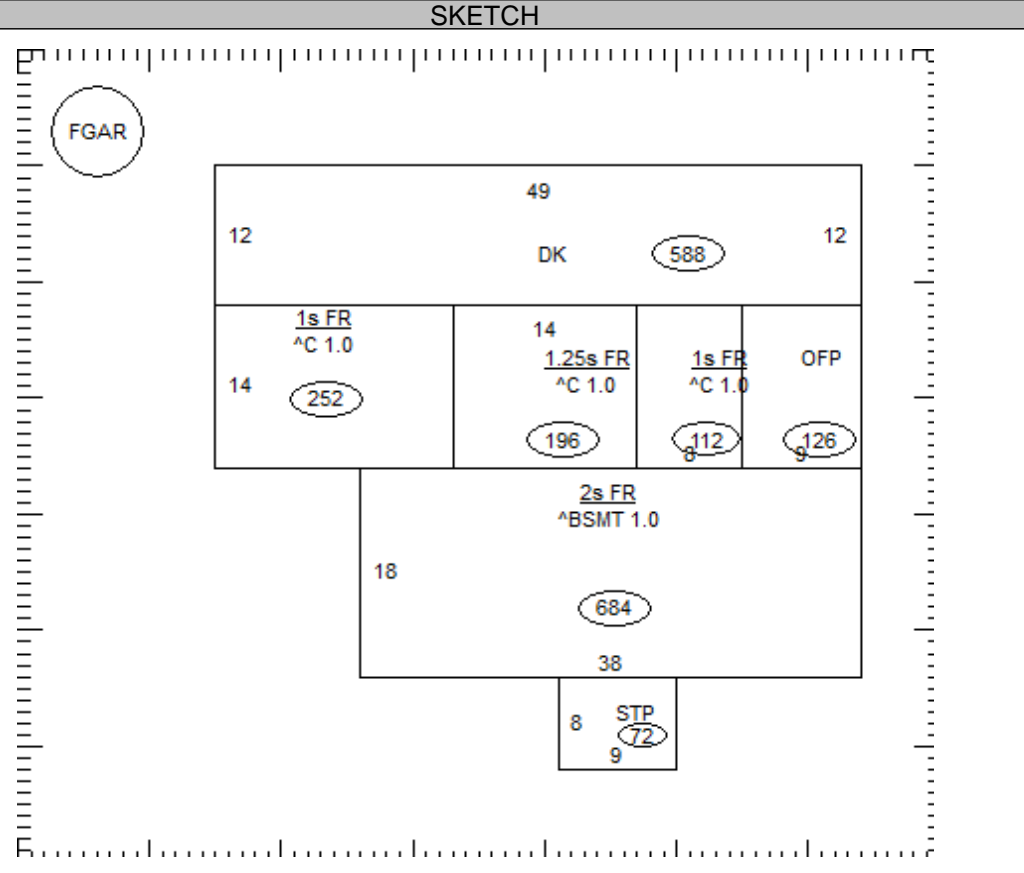

OCCUPANCY	ST.HT	SIZE	AREA	GRADE	PRICE	AGE	REMD	CND	UNADJ VAL	PHYS	PHYS VAL	FUNC	TRUE VAL
DWELLING		SK											
1													
2													
3													
4													
5													
6													
7													
8													
9													
10													
11													

07-081500.0000

TOTAL 0

COMMENTS