

OCCUPANCY
 SF DU TR
 CONVERSION
BUILDING TYPE
 MOBILE HOME
 BI/TR LEVEL
 MOD/MAN

FLOOR	AREA	CONST	VALUE
1	1111	FR	170,340

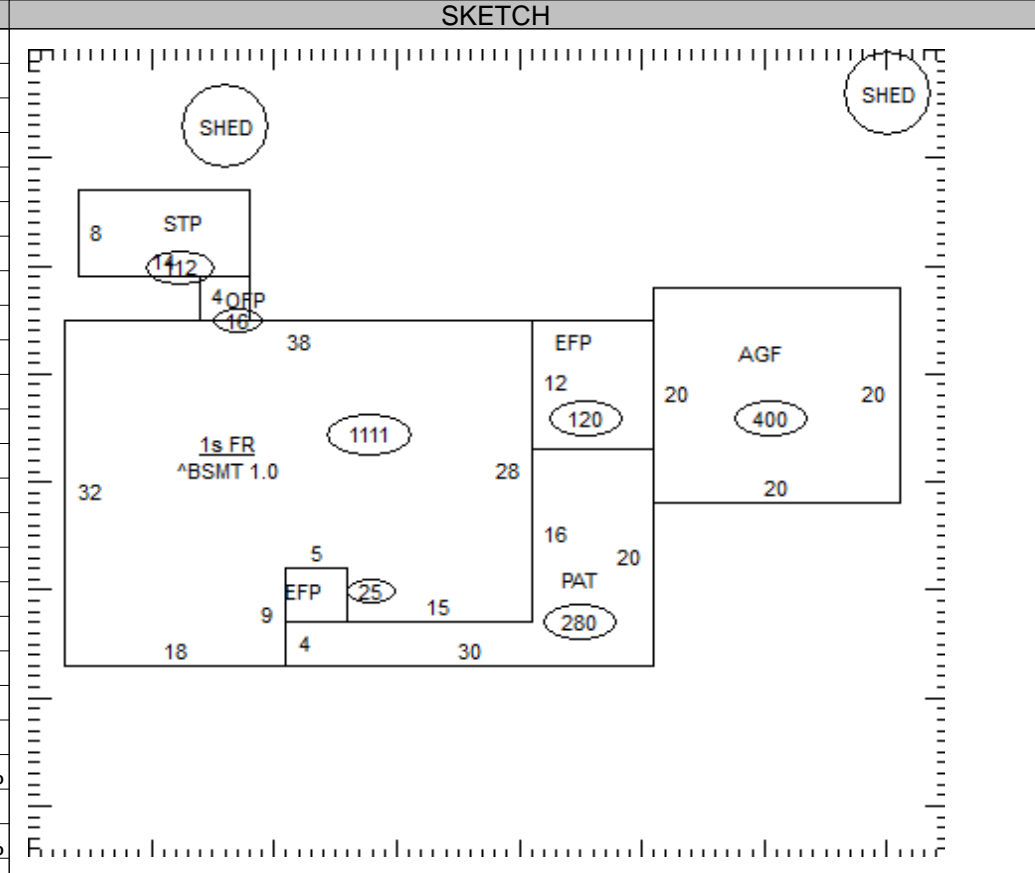

ROOFING
 METAL
 SLT/TLE
 SHINGLES
 SHAKES
 COMPOSITE

ROOF TYPE
 GABLE
 HIP
 GAMBREL
 MANSARD
 FLAT

BSMT	1111		15,890
SUBTOTAL			186,230
MULTI-FAMILY #	0		0
BUILDING TYPE	100%		0
BSMT FINISH	0 S.F.		0
FIREPLACE #	0		0
HEATING	0 S.F.		0
AIR COND	1,111 S.F.		1,830
PLUMBING #	0		0
GARAGES & CARPORTS			9,900
EXTRA FEATURES			6,700
SUBTOTAL			204,660
GRADE FACTOR			85 %
UNADJUSTED VALUE			173,960
FACTOR			100 %

FLOORS
 B 1 2 3 U
 CONCRETE
 WOOD
 TILE/COMPO
 CARPET

INT. FINISH	B 1 2 3 U		
PLASTER/DW	<input type="checkbox"/> <input checked="" type="checkbox"/> <input type="checkbox"/> <input type="checkbox"/> <input type="checkbox"/>		
PANELING	<input type="checkbox"/> <input checked="" type="checkbox"/> <input type="checkbox"/> <input type="checkbox"/> <input type="checkbox"/>		
UNFINISHED	<input checked="" type="checkbox"/> <input type="checkbox"/> <input type="checkbox"/> <input type="checkbox"/> <input type="checkbox"/>		

ACCOMMODATIONS
 # OF ROOMS 5
 BEDROOMS 2
 FIREPLACES
 HEAT & AC B 1 2 3 U

ACCUMULATED			
GRADE FACTOR			85 %
UNADJUSTED VALUE			173,960
FACTOR			100 %

HEAT & AC
 NO HEAT
 CTRL HEAT
 HW/STEAM
 ELECTRIC
 HEAT PUMP
 FLR/WALL
 STVE/SPCE
 GEOTHERMAL
 OUTSIDE
 CTRL A/C

OCCUPANCY	ST.HT	SIZE	AREA	GRADE	PRICE	AGE	REMD	CND	UNADJ VAL	PHYS	PHYS VAL	FUNC	TRUE VAL
DWELLING	1	SK	1,111	D+		1948		A	173,960	50	86,980		94,800
1 Shed		6x6	36	C		1990		A		57			0
2 Shed		4x4	16	C		1990		A		57			0
3													
4													
5													
6													
7													
8													
9													
10													
11													

PLUMBING
 X FULL BATH
 X HALF BATH
 X FIXTURES

OCCUPANCY	ST.HT	SIZE	AREA	GRADE	PRICE	AGE	REMD	CND	UNADJ VAL	PHYS	PHYS VAL	FUNC	TRUE VAL
DWELLING	1	SK	1,111	D+		1948		A	173,960	50	86,980		94,800
1 Shed		6x6	36	C		1990		A		57			0
2 Shed		4x4	16	C		1990		A		57			0
3													
4													
5													
6													
7													
8													
9													
10													
11													

07-044900.0000

TOTAL												94,800
--------------	--	--	--	--	--	--	--	--	--	--	--	--------

COMMENTS
 ASBESTOS SIDING
 Dwelling has an Economic Factor of 109%