

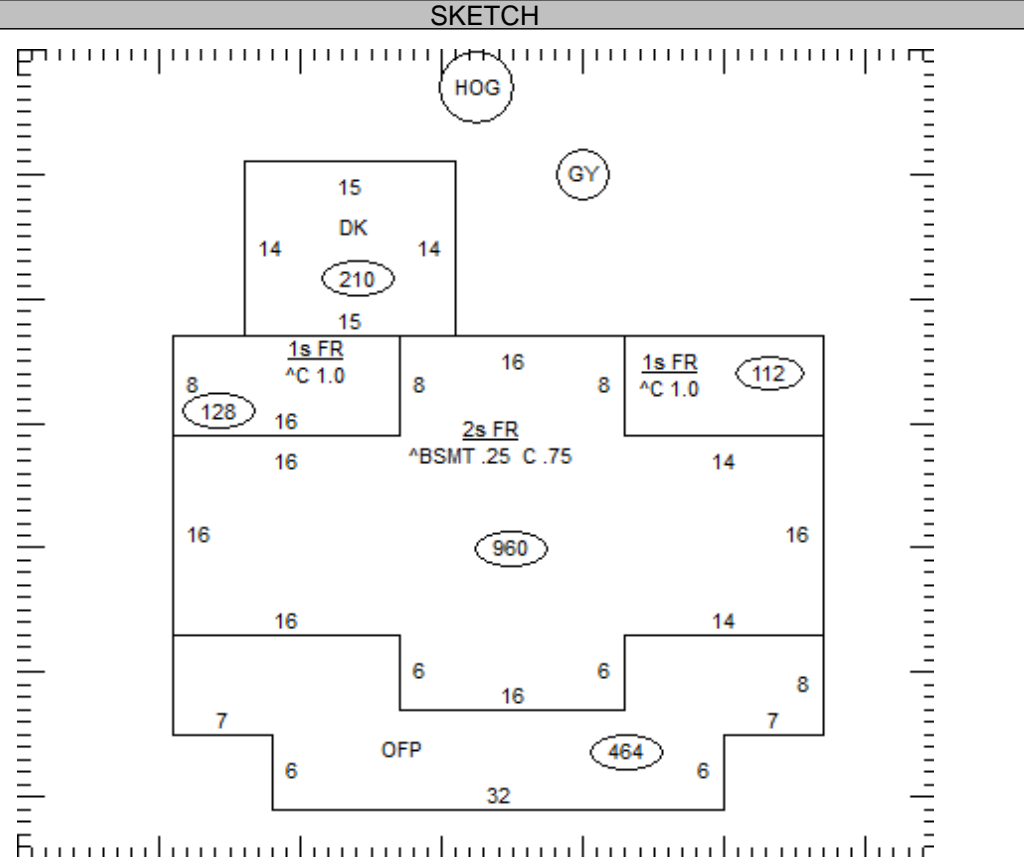

OCCUPANCY		EXTERIOR		FLOOR	AREA	CONST	VALUE						
<input checked="" type="checkbox"/> SF	<input type="checkbox"/> DU	<input type="checkbox"/> TR	<input type="checkbox"/> WOOD	1	1200	FR	177,660						
<input type="checkbox"/> CONVERSION	<input type="checkbox"/> STUCCO	<input type="checkbox"/> ALM/VYNL	<input type="checkbox"/> CONC BLK	2ND	960	FR	68,220						
<b>BUILDING TYPE</b>		<input type="checkbox"/> MOBILE HOME	<input type="checkbox"/> METAL										
<input type="checkbox"/> BI/TR LEVEL	<input type="checkbox"/> BRICK	<input type="checkbox"/> STONE											
<input type="checkbox"/> MOD/MAN													
<input type="checkbox"/>													
ROOFING		ROOF TYPE											
<input type="checkbox"/> METAL	<input checked="" type="checkbox"/> GABLE	<input type="checkbox"/> HIP											
<input type="checkbox"/> SLT/TLE	<input type="checkbox"/> GAMBREL	<input type="checkbox"/> MANSARD											
<input checked="" type="checkbox"/> SHINGLES	<input type="checkbox"/> FLAT												
<input type="checkbox"/> SHAKES													
<input type="checkbox"/> COMPOSITE													
FLOORS		B	1	2	3	U							
CONCRETE	<input type="checkbox"/>	<input type="checkbox"/>	<input type="checkbox"/>	<input type="checkbox"/>	<input type="checkbox"/>	<input type="checkbox"/>							
WOOD	<input type="checkbox"/>	<input checked="" type="checkbox"/>	<input checked="" type="checkbox"/>	<input type="checkbox"/>	<input type="checkbox"/>	<input type="checkbox"/>							
TILE/COMPO	<input type="checkbox"/>	<input type="checkbox"/>	<input type="checkbox"/>	<input type="checkbox"/>	<input type="checkbox"/>	<input type="checkbox"/>							
CARPET	<input type="checkbox"/>	<input type="checkbox"/>	<input type="checkbox"/>	<input type="checkbox"/>	<input type="checkbox"/>	<input type="checkbox"/>							
INT. FINISH		B	1	2	3	U							
PLASTER/DW	<input type="checkbox"/>	<input checked="" type="checkbox"/>	<input checked="" type="checkbox"/>	<input type="checkbox"/>	<input type="checkbox"/>	<input type="checkbox"/>							
PANELING	<input type="checkbox"/>	<input type="checkbox"/>	<input type="checkbox"/>	<input type="checkbox"/>	<input type="checkbox"/>	<input type="checkbox"/>							
UNFINISHED	<input checked="" type="checkbox"/>	<input type="checkbox"/>	<input type="checkbox"/>	<input type="checkbox"/>	<input type="checkbox"/>	<input type="checkbox"/>							
ACCOMMODATIONS													
# OF ROOMS		4	4										
BEDROOMS		1	2										
FIREPLACES		1											
HEAT & AC		B	1	2	3	U							
NO HEAT	<input type="checkbox"/>	<input type="checkbox"/>	<input checked="" type="checkbox"/>	<input type="checkbox"/>	<input type="checkbox"/>	<input type="checkbox"/>							
CTRL HEAT	<input type="checkbox"/>	<input checked="" type="checkbox"/>	<input type="checkbox"/>	<input type="checkbox"/>	<input type="checkbox"/>	<input type="checkbox"/>							
HW/STEAM	<input type="checkbox"/>	<input type="checkbox"/>	<input type="checkbox"/>	<input type="checkbox"/>	<input type="checkbox"/>	<input type="checkbox"/>							
ELECTRIC	<input type="checkbox"/>	<input type="checkbox"/>	<input type="checkbox"/>	<input type="checkbox"/>	<input type="checkbox"/>	<input type="checkbox"/>							
HEAT PUMP	<input type="checkbox"/>	<input type="checkbox"/>	<input type="checkbox"/>	<input type="checkbox"/>	<input type="checkbox"/>	<input type="checkbox"/>							
FLR/WALL	<input type="checkbox"/>	<input type="checkbox"/>	<input type="checkbox"/>	<input type="checkbox"/>	<input type="checkbox"/>	<input type="checkbox"/>							
STVE/SPCE	<input type="checkbox"/>	<input type="checkbox"/>	<input type="checkbox"/>	<input type="checkbox"/>	<input type="checkbox"/>	<input type="checkbox"/>							
GEO THERMAL	<input type="checkbox"/>	<input type="checkbox"/>	<input type="checkbox"/>	<input type="checkbox"/>	<input type="checkbox"/>	<input type="checkbox"/>							
OUTSIDE	<input type="checkbox"/>	<input type="checkbox"/>	<input type="checkbox"/>	<input type="checkbox"/>	<input type="checkbox"/>	<input type="checkbox"/>							
CTRL A/C	<input type="checkbox"/>	<input checked="" type="checkbox"/>	<input checked="" type="checkbox"/>	<input type="checkbox"/>	<input type="checkbox"/>	<input type="checkbox"/>							
PLUMBING		BASE		<input checked="" type="checkbox"/>									
X FULL BATH													
X HALF BATH													
X FIXTURES													
BSMT		240					3,430						
<b>SUBTOTAL</b>							249,310						
MULTI-FAMILY #	0						0						
BUILDING TYPE	100%						0						
BSMT FINISH	0 S.F.						0						
FIREPLACE #	1						4,400						
HEATING	960 S.F.						-3,650						
AIR COND	2,160 S.F.						3,560						
PLUMBING #	0						0						
GARAGES & CARPORTS							0						
EXTRA FEATURES							9,500						
<b>SUBTOTAL</b>							263,120						
GRADE FACTOR							105 %						
<b>UNADJUSTED VALUE</b>							276,280						
FACTOR							100 %						
OCCUPANCY	ST.HT	SIZE	AREA	GRADE	PRICE	AGE	REMD	CND	UNADJ VAL	PHYS	PHYS VAL	FUNC	TRUE VAL
DWELLING	2	SK	2,160	C+		1881		A	276,280	45	151,950		165,600
1 Granary	12	22x36	792	C	7.70	1881		A	6,100	95	310	DFLT50	200
2 Hog Hse	8	24x48	1,152	C	13.50	1881		A	15,550	95	780	DFLT50	400
3													
4													
5													
6													
7													
8													
9													
10													
11													



07-008300.0100

TOTAL 166,200

COMMENTS

Dwelling has an Economic Factor of 109%



