

06-051100.0100

DANIEL DANE T & AMBER JS

DANIEL DANE T & AMBER JS

7721 HOWICK RD

CELINA, OH 45822

LEGAL INFORMATION

PT SE SW

RTS: 003-05-22

Acres:2.0000

	OWNERSHIP	ADDRESS	CITY	STATE	ZIP	DATE	AMOUNT	DEED:CONV#	JS	VALID
1	DANIEL DANE T & AMBER JS	7721 HOWICK RD	CELINA	OH	45822	12/23/2020	290,000	SUC : 969	<input type="checkbox"/>	<input checked="" type="checkbox"/>
2	CONRAD GARY L & BARBARA	7721 HOWICK RD	CELINA	OH	45822	04/23/1985	10,400	: A : 0	<input type="checkbox"/>	<input checked="" type="checkbox"/>
3							0	0	<input type="checkbox"/>	<input type="checkbox"/>

X:  TTO LISTER: JK DATE: 03/12/2019 TIME: 12:00:00 AM  LETTER  LETTER REC'D GIS CODE

STREET/ROAD	TOPOGRAPHY	PU-UTILITIES-PR	NEIGHBORHOOD	INFLUENCE FACTORS	PROPERTY LOCATION
<input checked="" type="checkbox"/> PAVED	<input checked="" type="checkbox"/> LEVEL	<input type="checkbox"/> WATER <input type="checkbox"/>	<input type="checkbox"/> IMPROVING	<input type="checkbox"/> A. NO ROAD <input type="checkbox"/> F. RESTRICT	7721 HOWICK RD, CELINA
<input type="checkbox"/> GRAVEL	<input type="checkbox"/> HIGH	<input type="checkbox"/> SEWER <input type="checkbox"/>	<input type="checkbox"/> STATIC	<input type="checkbox"/> B. TOPGRHY <input type="checkbox"/> G. WOOD LT	COMMENT
<input type="checkbox"/> DIRT	<input type="checkbox"/> LOW	<input type="checkbox"/> GAS <input type="checkbox"/>	<input type="checkbox"/> DECLINING	<input type="checkbox"/> C. Ex Front <input type="checkbox"/> H. VACANCY	TY2022:Net Gen=\$3,020.66, Other
<input type="checkbox"/> SIDEWALKS	<input type="checkbox"/> ROLLING	<input type="checkbox"/> ELECTRIC <input type="checkbox"/>	<input type="checkbox"/> OLD	<input type="checkbox"/> D. QUANTITY <input type="checkbox"/> I. WATER FRONT	Assessment=\$4.00
<input type="checkbox"/> CURBS	<input type="checkbox"/> STANDARD	<input checked="" type="checkbox"/> STANDARD	<input type="checkbox"/> STANDARD	<input type="checkbox"/> E. SZ/SHAPE <input type="checkbox"/> J. OTHER/CDU	DE19 TTO; DMG REPAIRED; RMV FNC

LAND COMPUTATIONS						
LAND TYPE	SIZE	M	RATE	C	INF	M VALUE C
HS:Home Site	AC:1	18150				18,200 0
SM:Small Acreage	AC:1	8500				8,500 0
Total Acres: 2.0000					TOTAL	26,700 0

7721 HOWICK RD, CELINA  
 COMMENT  
 TY2022:Net Gen=\$3,020.66, Other  
 Assessment=\$4.00  
 DE19 TTO; DMG REPAIRED; RMV FNC  
 DE21 RMV HOMESTEAD CREDIT  
 DE22 RMV WDDK & PPP; DESKTOP RVW

VALUATION SUMMARY

VALUE YEAR	2023	2022	2020	2019	2018	2017		
REASON FOR CHANGE	RAPP	MISC	RAPP	NC	REMB	RAPP		
APPRAISED	LAND	26,700	25,900	25,900	23,500	23,500	23,500	
VALUE	IMPR	239,000	160,900	162,000	140,400	120,200	140,400	
	TOTAL	265,700	186,800	187,900	163,900	143,700	163,900	
ASSESSED	LAND	9,350	9,070	9,070	8,230	8,230	8,230	
VALUE	IMPR	83,650	56,320	56,700	49,140	42,070	49,140	
	TOTAL	93,000	65,390	65,770	57,370	50,300	57,370	

OCCUPANCY	EXTERIOR	FLOOR	AREA	CONST	VALUE
<input checked="" type="checkbox"/> SF <input type="checkbox"/> DU <input type="checkbox"/> TR	<input type="checkbox"/> WOOD	1	1716	FR	215,770
<input type="checkbox"/> CONVERSION	<input type="checkbox"/> STUCCO				
<b>BUILDING TYPE</b>	<input checked="" type="checkbox"/> ALM/VYNL				
<input type="checkbox"/> MOBILE HOME	<input type="checkbox"/> CONC BLK				
<input type="checkbox"/> BI/TR LEVEL	<input type="checkbox"/> METAL				
<input type="checkbox"/> MOD/MAN	<input checked="" type="checkbox"/> BRICK				
<input type="checkbox"/> _____	<input type="checkbox"/> STONE				
<b>ROOFING</b>	<b>ROOF TYPE</b>				
<input type="checkbox"/> METAL	<input checked="" type="checkbox"/> GABLE				
<input type="checkbox"/> SLT/TLE	<input type="checkbox"/> HIP				
<input checked="" type="checkbox"/> SHINGLES	<input type="checkbox"/> GAMBREL				
<input type="checkbox"/> SHAKES	<input type="checkbox"/> MANSARD				
<input type="checkbox"/> COMPOSITE	<input type="checkbox"/> FLAT				
<b>FLOORS</b>	<b>B 1 2 3 U</b>	BSMT	1692		24,200
CONCRETE	<input checked="" type="checkbox"/> <input type="checkbox"/> <input type="checkbox"/> <input type="checkbox"/> <input type="checkbox"/>	<b>SUBTOTAL</b>			239,970
WOOD	<input type="checkbox"/> <input checked="" type="checkbox"/> <input type="checkbox"/> <input type="checkbox"/> <input type="checkbox"/>	MULTI-FAMILY #	0		0
TILE/COMPO	<input type="checkbox"/> <input type="checkbox"/> <input type="checkbox"/> <input type="checkbox"/> <input type="checkbox"/>	BUILDING TYPE	100%		0
CARPET	<input checked="" type="checkbox"/> <input type="checkbox"/> <input type="checkbox"/> <input type="checkbox"/> <input type="checkbox"/>	BSMT FINISH	864 S.F.		12,360
<b>INT. FINISH</b>	<b>B 1 2 3 U</b>	FIREPLACE #	1		4,400
PLASTER/DW	<input type="checkbox"/> <input checked="" type="checkbox"/> <input type="checkbox"/> <input type="checkbox"/> <input type="checkbox"/>	HEATING	0 S.F.		0
PANELING	<input type="checkbox"/> <input type="checkbox"/> <input type="checkbox"/> <input type="checkbox"/> <input type="checkbox"/>	AIR COND	1,716 S.F.		2,830
UNFINISHED	<input checked="" type="checkbox"/> <input type="checkbox"/> <input type="checkbox"/> <input type="checkbox"/> <input type="checkbox"/>	PLUMBING #	5		6,050
<b>ACCOMMODATIONS</b>		GARAGES & CARPORTS			18,900
# OF ROOMS	8	EXTRA FEATURES			10,500
BEDROOMS	4	<b>SUBTOTAL</b>			295,010
FIREPLACES	1	GRADE FACTOR			105 %
HEAT & AC	<b>B 1 2 3 U</b>	<b>UNADJUSTED VALUE</b>			309,760
NO HEAT	<input type="checkbox"/> <input type="checkbox"/> <input type="checkbox"/> <input type="checkbox"/> <input type="checkbox"/>	FACTOR			100 %
CTRL HEAT	<input checked="" type="checkbox"/> <input checked="" type="checkbox"/> <input type="checkbox"/> <input type="checkbox"/> <input type="checkbox"/>				
HW/STEAM	<input type="checkbox"/> <input type="checkbox"/> <input type="checkbox"/> <input type="checkbox"/> <input type="checkbox"/>				
ELECTRIC	<input type="checkbox"/> <input type="checkbox"/> <input type="checkbox"/> <input type="checkbox"/> <input type="checkbox"/>				
HEAT PUMP	<input type="checkbox"/> <input type="checkbox"/> <input type="checkbox"/> <input type="checkbox"/> <input type="checkbox"/>				
FLR/WALL	<input type="checkbox"/> <input type="checkbox"/> <input type="checkbox"/> <input type="checkbox"/> <input type="checkbox"/>				
STVE/SPCE	<input type="checkbox"/> <input type="checkbox"/> <input type="checkbox"/> <input type="checkbox"/> <input type="checkbox"/>				
GEO THERMAL	<input type="checkbox"/> <input type="checkbox"/> <input type="checkbox"/> <input type="checkbox"/> <input type="checkbox"/>				
OUTSIDE	<input type="checkbox"/> <input type="checkbox"/> <input type="checkbox"/> <input type="checkbox"/> <input type="checkbox"/>				
CTRL A/C	<input type="checkbox"/> <input checked="" type="checkbox"/> <input type="checkbox"/> <input type="checkbox"/> <input type="checkbox"/>				
<b>PLUMBING</b>	<b>BASE</b> <input checked="" type="checkbox"/>				
X FULL BATH	1				
X HALF BATH	1				
X FIXTURES					

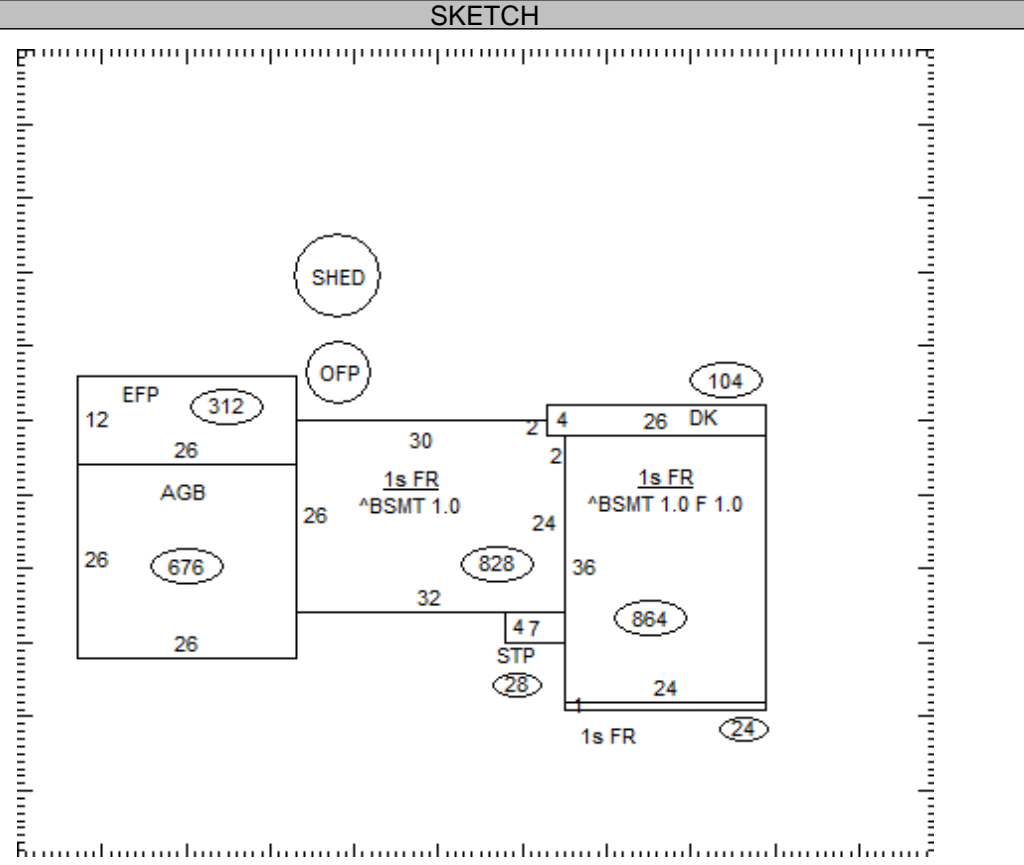

OCCUPANCY	ST.HT	SIZE	AREA	GRADE	PRICE	AGE	REMD	CND	UNADJ VAL	PHYS	PHYS VAL	FUNC	TRUE VAL
DWELLING	TRI	SK	1,716	C+		1985		A	309,760	28	223,030		234,200
1 Shed	10	20x26	520	C	12.53	1990		A	6,520	57	2,800		2,800
2 OFF	10	11x26	286	C	16.04	1990		A	4,590	57	1,970		2,000
3													
4													
5													
6													
7													
8													
9													
10													
11													

06-051100.0100

TOTAL 239,000

COMMENTS

>>OB Features: 1.1 <Unfinished Loft> <Add Concrete Floor>  
 Dwelling has an Economic Factor of 105% (Rollback Basis=\$252,400)