

CENTER TWP / CELINA SD

06-13-300-001

Property Class: 111

Neighborhood
009061-A100

Map: 10

Block:

Card: 06

Bk: Pg:

06-022100.0000

LEGAL INFORMATION

W 1/2 SW

**QUALIFIED CREDITS: CAUV:
06755: 2021**

RTS: 003-05-13
Acres:55.0000

LYME KEITH A
LYME KEITH A
8618 KUCK RD
CELINA, OH 45822

	OWNERSHIP	ADDRESS	CITY	STATE	ZIP	DATE	AMOUNT	DEED:CONV#	JS	VALID
1	LYME KEITH A	8618 KUCK RD	CELINA	OH	45822	07/15/2020	475,200	WDC : 455	<input type="checkbox"/>	<input checked="" type="checkbox"/>
2	MATHEWS FARMS LTD	6890 FAIR OAKS DR	CINCINNATI	OH	45237-9295	12/28/1994	0	: X : 0	<input type="checkbox"/>	<input type="checkbox"/>
3							0	0	<input type="checkbox"/>	<input type="checkbox"/>

X: TTO LISTER: HK DATE: 06/26/2023 TIME: 12:00:00 AM LETTER LETTER REC'D GIS CODE

STREET/ROAD	TOPOGRAPHY	PU-UTILITIES-PR	NEIGHBORHOOD	INFLUENCE FACTORS	PROPERTY LOCATION
<input checked="" type="checkbox"/> PAVED <input type="checkbox"/> GRAVEL <input type="checkbox"/> DIRT <input type="checkbox"/> SIDEWALKS <input type="checkbox"/> CURBS	<input checked="" type="checkbox"/> LEVEL <input type="checkbox"/> HIGH <input type="checkbox"/> LOW <input type="checkbox"/> ROLLING <input type="checkbox"/> STANDARD	<input type="checkbox"/> WATER <input type="checkbox"/> SEWER <input type="checkbox"/> GAS <input type="checkbox"/> ELECTRIC <input checked="" type="checkbox"/> STANDARD	<input type="checkbox"/> IMPROVING <input type="checkbox"/> STATIC <input type="checkbox"/> DECLINING <input type="checkbox"/> OLD <input type="checkbox"/> STANDARD	<input type="checkbox"/> A. NO ROAD <input type="checkbox"/> B. TOPGRHY <input type="checkbox"/> C. Ex Front <input type="checkbox"/> D. QUANTITY <input type="checkbox"/> E. SZ/SHAPE	<input type="checkbox"/> F. RESTRICT <input type="checkbox"/> G. WOOD LT <input type="checkbox"/> H. VACANCY <input type="checkbox"/> I. WATER FRONT <input type="checkbox"/> J. OTHER/CDU

8618 KUCK RD
COMMENT
TY2022:Net Gen=\$3,169.60, Other
Assessment=\$139.04
MATHEWS FARMS LTD
DE15 CLER ERR/COR OUTBLDG AGE DE15 RMV
GB VALUE PER ODT
DE17 DESKTOP RVW CHGS: ADD PATIO
DE23 TTO; RMV OLD DWLG, ADD NEW DWLG

LAND COMPUTATIONS						
LAND TYPE	SIZE	M	RATE	C	INF	M VALUE C
CR:Crop Land TOTAL	A 52.3110	11,750	2,920			608,490 149,830
0024	A 35.4080	11,250	2,540			398,340 89,940
0023	A .3190	11,550	2,660			3,680 850
0087	A 16.5840	12,450	3,560			206,470 59,040
HS:Home Site	A 1.0000	18,150	18,150			18,150 18,150
RD:Road	A 1.6890	0	0			0 0
Total Acres: 55.0000					TOTAL	626,640 167,980

VALUATION SUMMARY								
VALUE YEAR	2023	2023	2023	2023	2020	2020	2020	2020
REASON FOR CHANGE	CAUV	RAPP	CAUV	NC	CAUV	RAPP	CAUV	MISC
APPRAISED	LAND	167,980	626,640	89,960	626,640	88,310	479,610	479,600
VALUE	IMPR	422,400	422,400	422,400	422,400	103,800	103,800	103,800
	TOTAL	590,380	1,049,040	512,360	1,049,040	192,110	583,410	583,400
ASSESSED	LAND	58,790	219,320	31,490	219,320	30,910	167,860	167,860
VALUE	IMPR	147,840	147,840	147,840	147,840	36,330	36,330	36,330
	TOTAL	206,630	367,160	179,330	367,160	67,240	204,190	204,190
POTENTIAL RECOUP	2022=6455.60, 2021=6471.35, 2020=5468.89: Total=18395.84							

OCCUPANCY	EXTERIOR	FLOOR	AREA	CONST	VALUE
<input checked="" type="checkbox"/> SF <input type="checkbox"/> DU <input type="checkbox"/> TR	<input type="checkbox"/> WOOD	1	1832	FR	224,200
<input type="checkbox"/> CONVERSION	<input type="checkbox"/> STUCCO	2ND	532	FR	31,250
BUILDING TYPE	<input checked="" type="checkbox"/> ALM/VYNL				
<input type="checkbox"/> MOBILE HOME	<input type="checkbox"/> CONC BLK				
<input type="checkbox"/> BI/TR LEVEL	<input type="checkbox"/> METAL				
<input type="checkbox"/> MOD/MAN	<input type="checkbox"/> BRICK				
<input type="checkbox"/>	<input checked="" type="checkbox"/> STONE				
ROOFING	ROOF TYPE				
<input type="checkbox"/> METAL	<input checked="" type="checkbox"/> GABLE				
<input type="checkbox"/> SLT/TLE	<input type="checkbox"/> HIP				
<input checked="" type="checkbox"/> SHINGLES	<input type="checkbox"/> GAMBREL				
<input type="checkbox"/> SHAKES	<input type="checkbox"/> MANSARD				
<input type="checkbox"/> COMPOSITE	<input type="checkbox"/> FLAT				
FLOORS	B 1 2 3 U	BSMT	1832		26,200
CONCRETE	<input type="checkbox"/> <input type="checkbox"/> <input type="checkbox"/> <input type="checkbox"/> <input type="checkbox"/>	SUBTOTAL			281,650
WOOD	<input type="checkbox"/> <input type="checkbox"/> <input type="checkbox"/> <input type="checkbox"/> <input type="checkbox"/>	MULTI-FAMILY #	0		0
TILE/COMPO	<input type="checkbox"/> <input checked="" type="checkbox"/> <input checked="" type="checkbox"/> <input type="checkbox"/> <input type="checkbox"/>	BUILDING TYPE	100%		0
CARPET	<input type="checkbox"/> <input checked="" type="checkbox"/> <input checked="" type="checkbox"/> <input type="checkbox"/> <input type="checkbox"/>	BSMT FINISH	0 S.F.		0
INT. FINISH	B 1 2 3 U	FIREPLACE #	1		4,400
PLASTER/DW	<input type="checkbox"/> <input checked="" type="checkbox"/> <input checked="" type="checkbox"/> <input type="checkbox"/> <input type="checkbox"/>	HEATING	0 S.F.		0
PANELING	<input type="checkbox"/> <input type="checkbox"/> <input type="checkbox"/> <input type="checkbox"/> <input type="checkbox"/>	AIR COND	2,364 S.F.		3,900
UNFINISHED	<input checked="" type="checkbox"/> <input type="checkbox"/> <input type="checkbox"/> <input type="checkbox"/> <input type="checkbox"/>	PLUMBING #	5		6,050
ACCOMMODATIONS		GARAGES & CARPORTS			25,300
# OF ROOMS		EXTRA FEATURES			34,400
BEDROOMS		SUBTOTAL			355,700
FIREPLACES		GRADE FACTOR			105 %
HEAT & AC		UNADJUSTED VALUE			373,490
		FACTOR			100 %

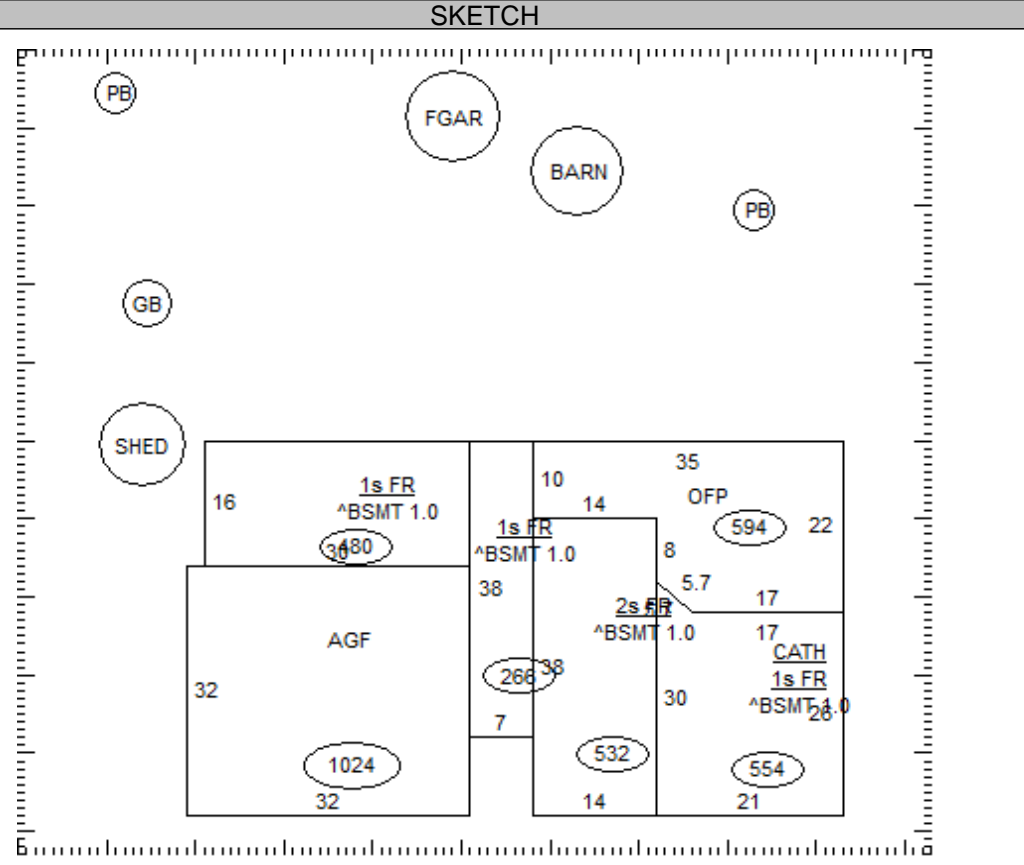

OCCUPANCY	ST.HT	SIZE	AREA	GRADE	PRICE	AGE	REMD	CND	UNADJ VAL	PHYS	PHYS VAL	FUNC	TRUE VAL
DWELLING	2	SK	2,364	C+		2022		G	373,490	1	369,760		388,200
1 Gar - Frame		22x24	528	C	23.70	1950		A	12,510	95	630		600
2 Pole Bldg	16	48x96	4,608	C	10.51	1996		A	48,430	47	25,670		25,700
3 Barn	16	44x64	2,816	C	12.00	1950		A	33,790	95	1,690	DFLT50	800
4 Pole Bldg	14	40x80	3,200	C	11.01	1973		A	35,230	80	7,050		7,100
5 Shed	PP	8x10	80	C		2000		A		37			0
6 Grain Bin	16	16x24	384	C		1996		A		47			0
7													
8													
9													
10													
11													

06-022100.0000

TOTAL 422,400

COMMENTS

RENTAL
Dwelling has an Economic Factor of 105%

06-022100.0000

LYME KEITH A

LYME KEITH A
8618 KUCK RD
CELINA, OH 45822

LEGAL INFORMATION

W 1/2 SW

RTS: 003-05-13
Acres:55.0000

QUALIFIED CREDITS: CAUV:
06755: 2021

	OWNERSHIP	ADDRESS	CITY	STATE	ZIP	DATE	AMOUNT	DEED:CONV#	JS	VALID
1	LYME KEITH A	8618 KUCK RD	CELINA	OH	45822	07/15/2020	475,200	WDC : 455	<input type="checkbox"/>	<input checked="" type="checkbox"/>
2	MATHEWS FARMS LTD	6890 FAIR OAKS DR	CINNATI	OH	45237-9295	12/28/1994	0	: X : 0	<input type="checkbox"/>	<input type="checkbox"/>
3							0	0	<input type="checkbox"/>	<input type="checkbox"/>

X: TTO LISTER: HK DATE: 06/26/2023 TIME: 12:00:00 AM LETTER LETTER REC'D GIS CODE

STREET/ROAD		TOPOGRAPHY		PU-UTILITIES-PR		NEIGHBORHOOD		INFLUENCE FACTORS				PROPERTY LOCATION	
<input checked="" type="checkbox"/> PAVED	<input checked="" type="checkbox"/> LEVEL	<input type="checkbox"/> WATER	<input type="checkbox"/> IMPROVING	<input type="checkbox"/> A. NO ROAD	<input type="checkbox"/> F. RESTRICT	8618 KUCK RD						COMMENT	
<input type="checkbox"/> GRAVEL	<input type="checkbox"/> HIGH	<input type="checkbox"/> SEWER	<input type="checkbox"/> STATIC	<input type="checkbox"/> B. TOPGRHY	<input type="checkbox"/> G. WOOD LT								
<input type="checkbox"/> DIRT	<input type="checkbox"/> LOW	<input type="checkbox"/> GAS	<input type="checkbox"/> DECLINING	<input type="checkbox"/> C. Ex Front	<input type="checkbox"/> H. VACANCY								
<input type="checkbox"/> SIDEWALKS	<input type="checkbox"/> ROLLING	<input type="checkbox"/> ELECTRIC	<input type="checkbox"/> OLD	<input type="checkbox"/> D. QUANTITY	<input type="checkbox"/> I. WATER FRONT								
<input type="checkbox"/> CURBS	<input type="checkbox"/> STANDARD	<input checked="" type="checkbox"/> STANDARD	<input type="checkbox"/> STANDARD	<input type="checkbox"/> E. SZ/SHAPE	<input type="checkbox"/> J. OTHER/CDU								
LAND COMPUTATIONS													
LAND TYPE		SIZE	M	RATE	C	INF	M	VALUE	C				
Total Acres: 55.0000								TOTAL	626,640	167,980			

VALUATION SUMMARY					
VALUE YEAR	2017	2017	2017	2017	
REASON FOR CHANGE	CAUV	RAPP	CAUV	MISC	
APPRAISED	<u>LAND</u>	189,500	682,580	247,730	629,840
VALUE	<u>IMPR</u>	97,700	97,700	102,400	102,400
	<u>TOTAL</u>	287,200	780,280	350,130	732,240
ASSESSED	<u>LAND</u>	66,330	238,900	86,710	220,440
VALUE	<u>IMPR</u>	34,200	34,200	35,840	35,840
	<u>TOTAL</u>	100,530	273,100	122,550	256,280
POTENTIAL RECOUP	2022=6455.60, 2021=6471.35, 2020=5468.89: Total=18395.84				

OCCUPANCY	EXTERIOR	FLOOR	AREA	CONST	VALUE
<input type="checkbox"/> SF <input type="checkbox"/> DU <input type="checkbox"/> TR	<input type="checkbox"/> WOOD				
<input type="checkbox"/> CONVERSION	<input type="checkbox"/> STUCCO				
BUILDING TYPE	<input type="checkbox"/> ALM/VYNL				
<input type="checkbox"/> MOBILE HOME	<input type="checkbox"/> CONC BLK				
<input type="checkbox"/> BI/TR LEVEL	<input type="checkbox"/> METAL				
<input type="checkbox"/> MOD/MAN	<input type="checkbox"/> BRICK				
<input type="checkbox"/>	<input type="checkbox"/> STONE				

ROOFING	ROOF TYPE
<input type="checkbox"/> METAL	<input type="checkbox"/> GABLE
<input type="checkbox"/> SLT/TLE	<input type="checkbox"/> HIP
<input type="checkbox"/> SHINGLES	<input type="checkbox"/> GAMBREL
<input type="checkbox"/> SHAKES	<input type="checkbox"/> MANSARD
<input type="checkbox"/> COMPOSITE	<input type="checkbox"/> FLAT

FLOORS	B	1	2	3	U
CONCRETE	<input type="checkbox"/>	<input type="checkbox"/>	<input type="checkbox"/>	<input type="checkbox"/>	<input type="checkbox"/>
WOOD	<input type="checkbox"/>	<input type="checkbox"/>	<input type="checkbox"/>	<input type="checkbox"/>	<input type="checkbox"/>
TILE/COMPO	<input type="checkbox"/>	<input type="checkbox"/>	<input type="checkbox"/>	<input type="checkbox"/>	<input type="checkbox"/>
CARPET	<input type="checkbox"/>	<input type="checkbox"/>	<input type="checkbox"/>	<input type="checkbox"/>	<input type="checkbox"/>
INT. FINISH	B	1	2	3	U
PLASTER/DW	<input type="checkbox"/>	<input type="checkbox"/>	<input type="checkbox"/>	<input type="checkbox"/>	<input type="checkbox"/>
PANELING	<input type="checkbox"/>	<input type="checkbox"/>	<input type="checkbox"/>	<input type="checkbox"/>	<input type="checkbox"/>
UNFINISHED	<input type="checkbox"/>	<input type="checkbox"/>	<input type="checkbox"/>	<input type="checkbox"/>	<input type="checkbox"/>
ACCOMMODATIONS					
# OF ROOMS					
BEDROOMS					
FIREPLACES					
HEAT & AC	B	1	2	3	U
NO HEAT	<input type="checkbox"/>	<input type="checkbox"/>	<input type="checkbox"/>	<input type="checkbox"/>	<input type="checkbox"/>
CTRL HEAT	<input type="checkbox"/>	<input type="checkbox"/>	<input type="checkbox"/>	<input type="checkbox"/>	<input type="checkbox"/>
HW/STEAM	<input type="checkbox"/>	<input type="checkbox"/>	<input type="checkbox"/>	<input type="checkbox"/>	<input type="checkbox"/>
ELECTRIC	<input type="checkbox"/>	<input type="checkbox"/>	<input type="checkbox"/>	<input type="checkbox"/>	<input type="checkbox"/>
HEAT PUMP	<input type="checkbox"/>	<input type="checkbox"/>	<input type="checkbox"/>	<input type="checkbox"/>	<input type="checkbox"/>
FLR/WALL	<input type="checkbox"/>	<input type="checkbox"/>	<input type="checkbox"/>	<input type="checkbox"/>	<input type="checkbox"/>
STVE/SPCE	<input type="checkbox"/>	<input type="checkbox"/>	<input type="checkbox"/>	<input type="checkbox"/>	<input type="checkbox"/>
GEO THERMAL	<input type="checkbox"/>	<input type="checkbox"/>	<input type="checkbox"/>	<input type="checkbox"/>	<input type="checkbox"/>
OUTSIDE	<input type="checkbox"/>	<input type="checkbox"/>	<input type="checkbox"/>	<input type="checkbox"/>	<input type="checkbox"/>
CTRL A/C	<input type="checkbox"/>	<input type="checkbox"/>	<input type="checkbox"/>	<input type="checkbox"/>	<input type="checkbox"/>
PLUMBING					BASE <input type="checkbox"/>
X FULL BATH					
X HALF BATH					
X FIXTURES					

SUBTOTAL		0
MULTI-FAMILY #	0	0
BUILDING TYPE	000%	0
BSMT FINISH	0 S.F.	0
FIREPLACE #	0	0
HEATING	0 S.F.	0
AIR COND	0 S.F.	0
PLUMBING #	0	0
GARAGES & CARPORTS		0
EXTRA FEATURES		0
SUBTOTAL		0
GRADE FACTOR		%
UNADJUSTED VALUE		0
FACTOR		%

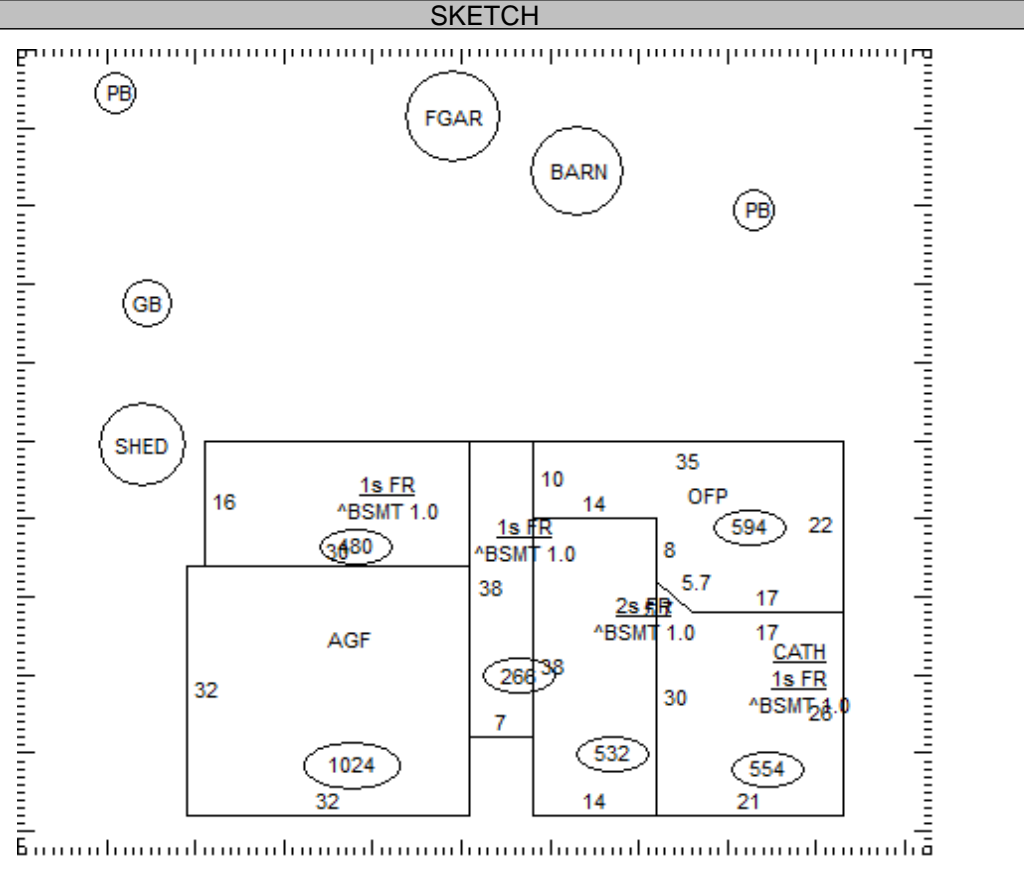

OCCUPANCY	ST.HT	SIZE	AREA	GRADE	PRICE	AGE	REMD	CND	UNADJ VAL	PHYS	PHYS VAL	FUNC	TRUE VAL
DWELLING		SK											
1													
2													
3													
4													
5													
6													
7													
8													
9													
10													
11													

06-022100.0000

TOTAL 0

COMMENTS