

CENTER TWP / CELINA SD

06-13-100-004

Property Class: 111

Neighborhood

009061-A100

Map: 10

Block:

Card: 04

Bk: Pg:

06-022000.0100

HOMAN GREGORY M & TANYA M

HOMAN GREGORY M & TANYA M

667 LOCK TWO RD

NEW BREMEN, OH 45869

Created in 2003 From 06-022000.0000 due to Split

LEGAL INFORMATION

PT W SIDE SW NW

RTS: 003-05-13

Acres: 1.7220

**QUALIFIED CREDITS: CAUV:
05870**

| | OWNERSHIP | ADDRESS | CITY | STATE | ZIP | DATE | AMOUNT | DEED:CONV# | JS | VALID |
|---|-------------------------|-----------------|------------|-------|-------|------------|-----------|---------------|--------------------------|-------------------------------------|
| 1 | HOMAN GREGORY M & TANYA | 667 LOCK TWO RD | NEW BREMEN | OH | 45869 | 11/14/2016 | 1,045,200 | 2:WDC : 807 | <input type="checkbox"/> | <input checked="" type="checkbox"/> |
| 2 | RASAWEHR JEFFREY E | 221 BALDWIN RD | BIRMINGHAM | MI | 48009 | 02/28/2013 | 0 | 2:QCE : X : 0 | <input type="checkbox"/> | <input type="checkbox"/> |
| 3 | RASAWEHR JEFFREY E & | 8820 KUCK RD | CELINA | OH | 45822 | 12/13/2000 | 135,000 | : A : 0 | <input type="checkbox"/> | <input checked="" type="checkbox"/> |

X: TTO LISTER: DATE: 11/24/2015 TIME: 12:00:00 AM LETTER LETTER REC'D GIS CODE Minor Sub

| STREET/ROAD | TOPOGRAPHY | PU-UTILITIES-PR | NEIGHBORHOOD | INFLUENCE FACTORS | PROPERTY LOCATION |
|---|---|--|------------------------------------|--|--|
| <input checked="" type="checkbox"/> PAVED | <input checked="" type="checkbox"/> LEVEL | <input type="checkbox"/> WATER <input type="checkbox"/> | <input type="checkbox"/> IMPROVING | <input type="checkbox"/> A. NO ROAD <input type="checkbox"/> F. RESTRICT | 8820 KUCK RD, CELINA |
| <input type="checkbox"/> GRAVEL | <input type="checkbox"/> HIGH | <input type="checkbox"/> SEWER <input type="checkbox"/> | <input type="checkbox"/> STATIC | <input type="checkbox"/> B. TOPGRHY <input type="checkbox"/> G. WOOD LT | COMMENT |
| <input type="checkbox"/> DIRT | <input type="checkbox"/> LOW | <input type="checkbox"/> GAS <input type="checkbox"/> | <input type="checkbox"/> DECLINING | <input type="checkbox"/> C. Ex Front <input type="checkbox"/> H. VACANCY | TY2022:Net Gen=\$2,796.24, Other |
| <input type="checkbox"/> SIDEWALKS | <input type="checkbox"/> ROLLING | <input type="checkbox"/> ELECTRIC <input type="checkbox"/> | <input type="checkbox"/> OLD | <input type="checkbox"/> D. QUANTITY <input type="checkbox"/> I. WATER FRONT | Assessment=\$6.72 |
| <input type="checkbox"/> CURBS | <input type="checkbox"/> STANDARD | <input checked="" type="checkbox"/> STANDARD | <input type="checkbox"/> STANDARD | <input type="checkbox"/> E. SZ/SHAPE <input type="checkbox"/> J. OTHER/CDU | DE15 RMV 20% USE ON DWLGG/ NOT VACANT/ USED AS RENTAL |

LAND COMPUTATIONS

| LAND TYPE | SIZE | M | RATE | C | INF | M | VALUE | C |
|---------------------|----------|--------|--------|---|-------|--------|--------|---|
| CR:Crop Land:0024 | A .6290 | 11,250 | 2,540 | | | 7,080 | 1,600 | |
| HS:Home Site | A 1.0000 | 18,150 | 18,150 | | | 18,150 | 18,150 | |
| RD:Road | A .0930 | 0 | 0 | | | 0 | 0 | |
| Total Acres: 1.7220 | | | | | TOTAL | 25,230 | 19,750 | |

VALUATION SUMMARY

| VALUE YEAR | 2023 | 2023 | 2022 | 2022 | 2020 | 2020 | 2017 | 2017 |
|-------------------|--|---------|---------|---------|---------|---------|---------|---------|
| REASON FOR CHANGE | CAUV | RAPP | CAUV | MISC | CAUV | RAPP | CAUV | RAPP |
| APPRAISED | 19,750 | 25,230 | 17,170 | 21,880 | 17,170 | 21,880 | 17,910 | 22,600 |
| VALUE | IMPR | 234,500 | 234,500 | 152,300 | 152,300 | 169,300 | 163,000 | 163,000 |
| | TOTAL | 254,250 | 259,730 | 169,470 | 174,180 | 186,470 | 191,180 | 185,600 |
| ASSESSED | LAND | 6,910 | 8,830 | 6,010 | 7,660 | 6,010 | 7,660 | 6,270 |
| VALUE | IMPR | 82,080 | 82,080 | 53,310 | 53,310 | 59,260 | 57,050 | 57,050 |
| | TOTAL | 88,990 | 90,910 | 59,320 | 60,970 | 65,270 | 63,320 | 64,960 |
| POTENTIAL RECOUP | 2022=77.78, 2021=77.97, 2020=65.89: Total=221.64 | | | | | | | |

| OCCUPANCY | EXTERIOR | FLOOR | AREA | CONST | VALUE |
|--|---|-------|------|-------|---------|
| <input checked="" type="checkbox"/> SF <input type="checkbox"/> DU <input type="checkbox"/> TR | <input type="checkbox"/> WOOD | 1 | 520 | FR | 58,580 |
| <input type="checkbox"/> CONVERSION | <input type="checkbox"/> STUCCO | 1 | 1716 | BRK | 206,830 |
| BUILDING TYPE | <input type="checkbox"/> ALM/VYNL | | | | |
| <input type="checkbox"/> MOBILE HOME | <input type="checkbox"/> CONC BLK | | | | |
| <input type="checkbox"/> BI/TR LEVEL | <input type="checkbox"/> METAL | | | | |
| <input type="checkbox"/> MOD/MAN | <input checked="" type="checkbox"/> BRICK | | | | |
| <input type="checkbox"/> | <input type="checkbox"/> STONE | | | | |

| ROOFING | ROOF TYPE |
|--|---|
| <input type="checkbox"/> METAL | <input type="checkbox"/> GABLE |
| <input type="checkbox"/> SLT/TLE | <input checked="" type="checkbox"/> HIP |
| <input checked="" type="checkbox"/> SHINGLES | <input type="checkbox"/> GAMBREL |
| <input type="checkbox"/> SHAKES | <input type="checkbox"/> MANSARD |
| <input type="checkbox"/> COMPOSITE | <input type="checkbox"/> FLAT |

| FLOORS | B | 1 | 2 | 3 | U |
|----------------|--|--------------------------|-------------------------------------|--------------------------|--------------------------|
| CONCRETE | <input checked="" type="checkbox"/> | <input type="checkbox"/> | <input type="checkbox"/> | <input type="checkbox"/> | <input type="checkbox"/> |
| WOOD | <input type="checkbox"/> | <input type="checkbox"/> | <input type="checkbox"/> | <input type="checkbox"/> | <input type="checkbox"/> |
| TILE/COMPO | <input type="checkbox"/> | <input type="checkbox"/> | <input checked="" type="checkbox"/> | <input type="checkbox"/> | <input type="checkbox"/> |
| CARPET | <input type="checkbox"/> | <input type="checkbox"/> | <input checked="" type="checkbox"/> | <input type="checkbox"/> | <input type="checkbox"/> |
| INT. FINISH | B | 1 | 2 | 3 | U |
| PLASTER/DW | <input type="checkbox"/> | <input type="checkbox"/> | <input checked="" type="checkbox"/> | <input type="checkbox"/> | <input type="checkbox"/> |
| PANELING | <input type="checkbox"/> | <input type="checkbox"/> | <input type="checkbox"/> | <input type="checkbox"/> | <input type="checkbox"/> |
| UNFINISHED | <input checked="" type="checkbox"/> | <input type="checkbox"/> | <input type="checkbox"/> | <input type="checkbox"/> | <input type="checkbox"/> |
| ACCOMMODATIONS | | | | | |
| # OF ROOMS | | | 6 | | |
| BEDROOMS | | | 4 | | |
| FIREPLACES | | | | | |
| HEAT & AC | B | 1 | 2 | 3 | U |
| NO HEAT | <input type="checkbox"/> | <input type="checkbox"/> | <input type="checkbox"/> | <input type="checkbox"/> | <input type="checkbox"/> |
| CTRL HEAT | <input type="checkbox"/> | <input type="checkbox"/> | <input checked="" type="checkbox"/> | <input type="checkbox"/> | <input type="checkbox"/> |
| HW/STEAM | <input type="checkbox"/> | <input type="checkbox"/> | <input type="checkbox"/> | <input type="checkbox"/> | <input type="checkbox"/> |
| ELECTRIC | <input type="checkbox"/> | <input type="checkbox"/> | <input type="checkbox"/> | <input type="checkbox"/> | <input type="checkbox"/> |
| HEAT PUMP | <input type="checkbox"/> | <input type="checkbox"/> | <input type="checkbox"/> | <input type="checkbox"/> | <input type="checkbox"/> |
| FLR/WALL | <input type="checkbox"/> | <input type="checkbox"/> | <input type="checkbox"/> | <input type="checkbox"/> | <input type="checkbox"/> |
| STVE/SPCE | <input type="checkbox"/> | <input type="checkbox"/> | <input type="checkbox"/> | <input type="checkbox"/> | <input type="checkbox"/> |
| GEOHERMAL | <input type="checkbox"/> | <input type="checkbox"/> | <input type="checkbox"/> | <input type="checkbox"/> | <input type="checkbox"/> |
| OUTSIDE | <input type="checkbox"/> | <input type="checkbox"/> | <input type="checkbox"/> | <input type="checkbox"/> | <input type="checkbox"/> |
| CTRL A/C | <input type="checkbox"/> | <input type="checkbox"/> | <input checked="" type="checkbox"/> | <input type="checkbox"/> | <input type="checkbox"/> |
| PLUMBING | BASE <input checked="" type="checkbox"/> | | | | |
| X FULL BATH | | | 1 | | |
| X HALF BATH | | | | | |
| X FIXTURES | | | | | |

| | | | |
|-------------------------|------------|--|---------|
| BSMT | 1716 | | 24,540 |
| SUBTOTAL | | | 289,950 |
| MULTI-FAMILY # | 0 | | 0 |
| BUILDING TYPE | 100% | | 0 |
| BSMT FINISH | 0 S.F. | | 0 |
| FIREPLACE # | 0 | | 0 |
| HEATING | 0 S.F. | | 0 |
| AIR COND | 1,716 S.F. | | 2,830 |
| PLUMBING # | 3 | | 3,630 |
| GARAGES & CARPORTS | | | 20,700 |
| EXTRA FEATURES | | | 3,800 |
| SUBTOTAL | | | 320,910 |
| GRADE FACTOR | | | 100 % |
| UNADJUSTED VALUE | | | 320,910 |
| FACTOR | | | 100 % |

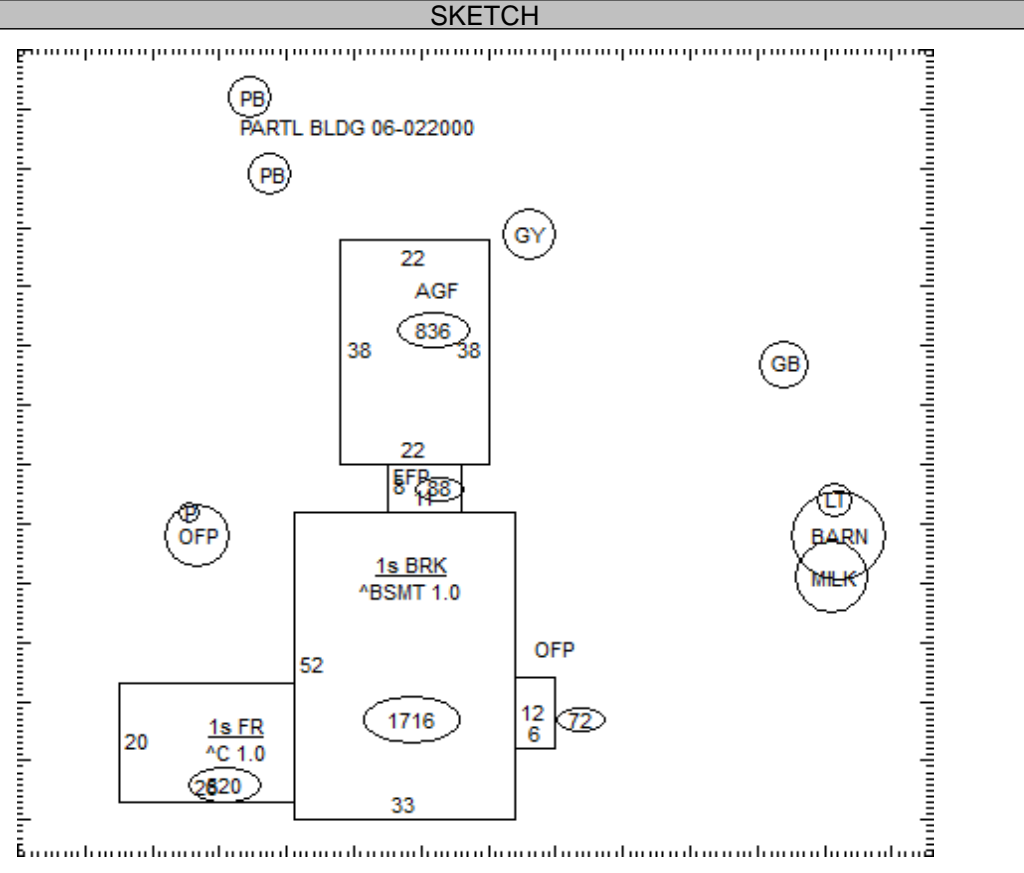

| OCCUPANCY | ST.HT | SIZE | AREA | GRADE | PRICE | AGE | REMD | CND | UNADJ VAL | PHYS | PHYS VAL | FUNC | TRUE VAL |
|--------------------|-------|-------|-------|-------|-------|------|------|-----|-----------|------|----------|--------|----------|
| DWELLING | 1 | SK | 2,236 | C | | 1970 | | A | 320,910 | 40 | 192,550 | | 202,200 |
| 1 Milk House / Par | | 10x12 | 120 | C | 18.00 | 1947 | | A | 2,160 | 95 | 110 | DFLT50 | 100 |
| 2 Pole Bldg | 16 | 46x80 | 3,680 | D | 8.70 | 2000 | | A | 32,020 | 38 | 19,850 | | 19,900 |
| 3 Lean - To | 8 | 30x37 | 1,110 | D | 3.84 | 2000 | | A | 4,260 | 38 | 2,640 | | 2,600 |
| 4 Barn | 16 | 40x56 | 2,240 | D | 9.60 | 1946 | | A | 21,500 | 95 | 1,080 | DFLT50 | 500 |
| 5 Pole Bldg | 12 | 48x40 | 1,920 | C | 12.16 | 1973 | | A | 23,350 | 80 | 4,670 | | 4,700 |
| 6 Grain Bin | 24 | 24x21 | 504 | C | | 1980 | | A | | 77 | | | 0 |
| 7 Granary | 12 | 24x30 | 720 | C | 7.70 | 1970 | | A | 5,540 | 85 | 830 | DFLT50 | 400 |
| 8 Patio | | 8x16 | 128 | C | 4.05 | 2010 | | A | 520 | 21 | 410 | | 400 |
| 9 OFP | | 16x18 | 288 | C | 16.04 | 2010 | | A | 4,620 | 21 | 3,650 | | 3,700 |
| 10 | | | | | | | | | | | | | |
| 11 | | | | | | | | | | | | | |

| | | |
|----------------|--------------|---------|
| 06-022000.0100 | TOTAL | 234,500 |
|----------------|--------------|---------|

COMMENTS

Dwelling has an Economic Factor of 105%

CENTER TWP / CELINA SD

06-13-100-004

Property Class: 111

Neighborhood

009061-A100

Map: 10

Block:

Card: 04

Bk: Pg:

06-022000.0100

LEGAL INFORMATION

PT W SIDE SW NW

**QUALIFIED CREDITS: CAUV:
05870**

RTS: 003-05-13
Acres: 1.7220

HOMAN GREGORY M & TANYA M

HOMAN GREGORY M & TANYA M

667 LOCK TWO RD

NEW BREMEN, OH 45869

Created in 2003 From 06-022000.0000 due to Split

| | OWNERSHIP | ADDRESS | CITY | STATE | ZIP | DATE | AMOUNT | DEED:CONV# | JS | VALID |
|---|-------------------------|-----------------|------------|-------|-------|------------|-----------|---------------|--------------------------|-------------------------------------|
| 1 | HOMAN GREGORY M & TANYA | 667 LOCK TWO RD | NEW BREMEN | OH | 45869 | 11/14/2016 | 1,045,200 | 2:WDC : 807 | <input type="checkbox"/> | <input checked="" type="checkbox"/> |
| 2 | RASAWEHR JEFFREY E | 221 BALDWIN RD | BIRMINGHAM | MI | 48009 | 02/28/2013 | 0 | 2:QCE : X : 0 | <input type="checkbox"/> | <input type="checkbox"/> |
| 3 | RASAWEHR JEFFREY E & | 8820 KUCK RD | CELINA | OH | 45822 | 12/13/2000 | 135,000 | : A : 0 | <input type="checkbox"/> | <input checked="" type="checkbox"/> |

X: TTO LISTER: DATE: 11/24/2015 TIME: 12:00:00 AM LETTER LETTER REC'D GIS CODE Minor Sub

| STREET/ROAD | TOPOGRAPHY | PU-UTILITIES-PR | NEIGHBORHOOD | INFLUENCE FACTORS | PROPERTY LOCATION |
|---|---|--|------------------------------------|--|----------------------|
| <input checked="" type="checkbox"/> PAVED | <input checked="" type="checkbox"/> LEVEL | <input type="checkbox"/> WATER <input type="checkbox"/> | <input type="checkbox"/> IMPROVING | <input type="checkbox"/> A. NO ROAD <input type="checkbox"/> F. RESTRICT | 8820 KUCK RD, CELINA |
| <input type="checkbox"/> GRAVEL | <input type="checkbox"/> HIGH | <input type="checkbox"/> SEWER <input type="checkbox"/> | <input type="checkbox"/> STATIC | <input type="checkbox"/> B. TOPGRHY <input type="checkbox"/> G. WOOD LT | COMMENT |
| <input type="checkbox"/> DIRT | <input type="checkbox"/> LOW | <input type="checkbox"/> GAS <input type="checkbox"/> | <input type="checkbox"/> DECLINING | <input type="checkbox"/> C. Ex Front <input type="checkbox"/> H. VACANCY | |
| <input type="checkbox"/> SIDEWALKS | <input type="checkbox"/> ROLLING | <input type="checkbox"/> ELECTRIC <input type="checkbox"/> | <input type="checkbox"/> OLD | <input type="checkbox"/> D. QUANTITY <input type="checkbox"/> I. WATER FRONT | |
| <input type="checkbox"/> CURBS | <input type="checkbox"/> STANDARD | <input checked="" type="checkbox"/> STANDARD | <input type="checkbox"/> STANDARD | <input type="checkbox"/> E. SZ/SHAPE <input type="checkbox"/> J. OTHER/CDU | |

| LAND COMPUTATIONS | | | | | | | |
|---------------------|------|---|------|---|-------|--------|---------|
| LAND TYPE | SIZE | M | RATE | C | INF | M | VALUE C |
| | | | | | | | |
| | | | | | | | |
| | | | | | | | |
| | | | | | | | |
| | | | | | | | |
| | | | | | | | |
| | | | | | | | |
| | | | | | | | |
| | | | | | | | |
| Total Acres: 1.7220 | | | | | TOTAL | 25,230 | 19,750 |

VALUATION SUMMARY

| VALUE YEAR | 2017 | 2017 | | | | | |
|-------------------|--|---------|---------|--|--|--|--|
| REASON FOR CHANGE | CAUV | MISC | | | | | |
| APPRaised | LAND | 16,960 | 20,630 | | | | |
| VALUE | IMPR | 177,100 | 177,100 | | | | |
| | TOTAL | 194,060 | 197,730 | | | | |
| ASSESSED | LAND | 5,940 | 7,220 | | | | |
| VALUE | IMPR | 61,990 | 61,990 | | | | |
| | TOTAL | 67,930 | 69,210 | | | | |
| POTENTIAL RECOUP | 2022=77.78, 2021=77.97, 2020=65.89: Total=221.64 | | | | | | |

| | | | | | | | |
|--------------------------------------|-----------------------------|-----------------------------|-----------------------------------|-------|------|-------|-------|
| OCCUPANCY | | EXTERIOR | | FLOOR | AREA | CONST | VALUE |
| <input type="checkbox"/> SF | <input type="checkbox"/> DU | <input type="checkbox"/> TR | <input type="checkbox"/> WOOD | | | | |
| CONVERSION | | | <input type="checkbox"/> STUCCO | | | | |
| BUILDING TYPE | | | <input type="checkbox"/> ALM/VYNL | | | | |
| <input type="checkbox"/> MOBILE HOME | | | <input type="checkbox"/> CONC BLK | | | | |
| <input type="checkbox"/> BI/TR LEVEL | | | <input type="checkbox"/> METAL | | | | |
| <input type="checkbox"/> MOD/MAN | | | <input type="checkbox"/> BRICK | | | | |
| <input type="checkbox"/> | | | <input type="checkbox"/> STONE | | | | |

| | | | |
|------------------------------------|----------------------------------|-----------------------------------|----------------------------------|
| ROOFING | | ROOF TYPE | |
| <input type="checkbox"/> METAL | <input type="checkbox"/> SLT/TLE | <input type="checkbox"/> SHINGLES | <input type="checkbox"/> SHAKES |
| <input type="checkbox"/> COMPOSITE | <input type="checkbox"/> GABLE | <input type="checkbox"/> HIP | <input type="checkbox"/> GAMBREL |
| | <input type="checkbox"/> MANSARD | <input type="checkbox"/> FLAT | |

| | | | | | | | | | |
|----------------|--------------------------|--------------------------|--------------------------|--------------------------|--------------------------|--------------------------|--------------------|--------|--|
| FLOORS | | B | 1 | 2 | 3 | U | SUBTOTAL | 0 | |
| CONCRETE | <input type="checkbox"/> | <input type="checkbox"/> | <input type="checkbox"/> | <input type="checkbox"/> | <input type="checkbox"/> | <input type="checkbox"/> | MULTI-FAMILY # | 0 | |
| WOOD | <input type="checkbox"/> | <input type="checkbox"/> | <input type="checkbox"/> | <input type="checkbox"/> | <input type="checkbox"/> | <input type="checkbox"/> | BUILDING TYPE | 000% | |
| TILE/COMPO | <input type="checkbox"/> | <input type="checkbox"/> | <input type="checkbox"/> | <input type="checkbox"/> | <input type="checkbox"/> | <input type="checkbox"/> | BSMT FINISH | 0 S.F. | |
| CARPET | <input type="checkbox"/> | <input type="checkbox"/> | <input type="checkbox"/> | <input type="checkbox"/> | <input type="checkbox"/> | <input type="checkbox"/> | FIREPLACE # | 0 | |
| INT. FINISH | | B | 1 | 2 | 3 | U | HEATING | 0 S.F. | |
| PLASTER/DW | <input type="checkbox"/> | <input type="checkbox"/> | <input type="checkbox"/> | <input type="checkbox"/> | <input type="checkbox"/> | <input type="checkbox"/> | AIR COND | 0 S.F. | |
| PANELING | <input type="checkbox"/> | <input type="checkbox"/> | <input type="checkbox"/> | <input type="checkbox"/> | <input type="checkbox"/> | <input type="checkbox"/> | PLUMBING # | 0 | |
| UNFINISHED | <input type="checkbox"/> | <input type="checkbox"/> | <input type="checkbox"/> | <input type="checkbox"/> | <input type="checkbox"/> | <input type="checkbox"/> | GARAGES & CARPORTS | 0 | |
| ACCOMMODATIONS | | | | | | | SUBTOTAL | 0 | |
| # OF ROOMS | | | | | | | GRADE FACTOR | % | |
| BEDROOMS | | | | | | | UNADJUSTED VALUE | 0 | |
| FIREPLACES | | | | | | | FACTOR | % | |
| HEAT & AC | | B | 1 | 2 | 3 | U | | | |
| NO HEAT | <input type="checkbox"/> | <input type="checkbox"/> | <input type="checkbox"/> | <input type="checkbox"/> | <input type="checkbox"/> | <input type="checkbox"/> | | | |
| CTRL HEAT | <input type="checkbox"/> | <input type="checkbox"/> | <input type="checkbox"/> | <input type="checkbox"/> | <input type="checkbox"/> | <input type="checkbox"/> | | | |
| HW/STEAM | <input type="checkbox"/> | <input type="checkbox"/> | <input type="checkbox"/> | <input type="checkbox"/> | <input type="checkbox"/> | <input type="checkbox"/> | | | |
| ELECTRIC | <input type="checkbox"/> | <input type="checkbox"/> | <input type="checkbox"/> | <input type="checkbox"/> | <input type="checkbox"/> | <input type="checkbox"/> | | | |
| HEAT PUMP | <input type="checkbox"/> | <input type="checkbox"/> | <input type="checkbox"/> | <input type="checkbox"/> | <input type="checkbox"/> | <input type="checkbox"/> | | | |
| FLR/WALL | <input type="checkbox"/> | <input type="checkbox"/> | <input type="checkbox"/> | <input type="checkbox"/> | <input type="checkbox"/> | <input type="checkbox"/> | | | |
| STVE/SPCE | <input type="checkbox"/> | <input type="checkbox"/> | <input type="checkbox"/> | <input type="checkbox"/> | <input type="checkbox"/> | <input type="checkbox"/> | | | |
| GEO THERMAL | <input type="checkbox"/> | <input type="checkbox"/> | <input type="checkbox"/> | <input type="checkbox"/> | <input type="checkbox"/> | <input type="checkbox"/> | | | |
| OUTSIDE | <input type="checkbox"/> | <input type="checkbox"/> | <input type="checkbox"/> | <input type="checkbox"/> | <input type="checkbox"/> | <input type="checkbox"/> | | | |
| CTRL A/C | <input type="checkbox"/> | <input type="checkbox"/> | <input type="checkbox"/> | <input type="checkbox"/> | <input type="checkbox"/> | <input type="checkbox"/> | | | |
| PLUMBING | | BASE | | <input type="checkbox"/> | | | | | |
| X FULL BATH | | | | | | | | | |
| X HALF BATH | | | | | | | | | |
| X FIXTURES | | | | | | | | | |

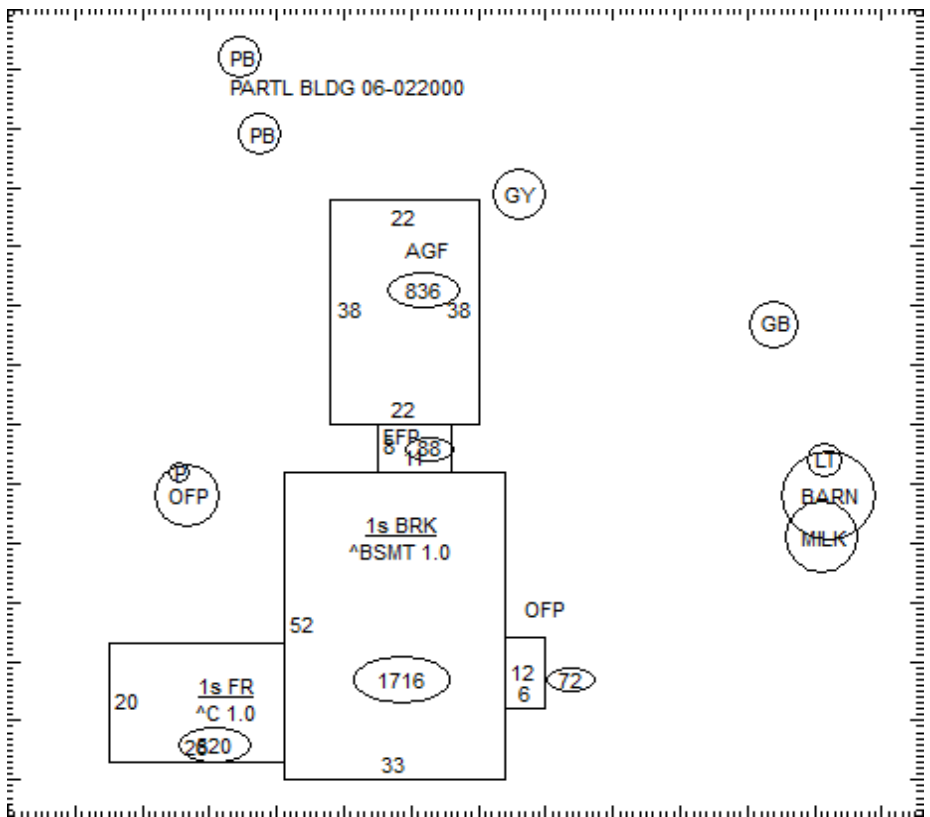

| OCCUPANCY | ST.HT | SIZE | AREA | GRADE | PRICE | AGE | REMD | CND | UNADJ VAL | PHYS | PHYS VAL | FUNC | TRUE VAL |
|-----------|-------|------|------|-------|-------|-----|------|-----|-----------|------|----------|------|----------|
| DWELLING | | SK | | | | | | | | | | | |
| 1 | | | | | | | | | | | | | |
| 2 | | | | | | | | | | | | | |
| 3 | | | | | | | | | | | | | |
| 4 | | | | | | | | | | | | | |
| 5 | | | | | | | | | | | | | |
| 6 | | | | | | | | | | | | | |
| 7 | | | | | | | | | | | | | |
| 8 | | | | | | | | | | | | | |
| 9 | | | | | | | | | | | | | |
| 10 | | | | | | | | | | | | | |
| 11 | | | | | | | | | | | | | |

06-022000.0100

TOTAL 0

COMMENTS