

CENTER TWP / CELINA SD

06-09-100-002

AGR DISTRICT: CEN18:2019:2024

Property Class: 113

Neighborhood  
009061-A100

Map: 06

Block:

Card: 06

Bk: Pg:

06-016800.0100

**MVP DAIRY LLC**  
MVP DAIRY LLC  
PO BOX 968  
COLBY, KS 67701

**LEGAL INFORMATION**  
PT W 1/2 NW

RTS: 003-06-09  
Acres:77.6370

**QUALIFIED CREDITS: CAUV:**  
**06656: 2019**  
**REDIR: TIF**

	OWNERSHIP	ADDRESS	CITY	STATE	ZIP	DATE	AMOUNT	DEED:CONV#	JS	VALID
1	MVP DAIRY LLC	PO BOX 968	COLBY	KS	67701	03/26/2018	1,312,500	2:WDC : 171	<input type="checkbox"/>	<input type="checkbox"/>
2	ELMGLADE HOLDINGS LLC	PO BOX 968	COLBY	KS	67701	03/26/2018	0	2:QCE : X : 0	<input type="checkbox"/>	<input type="checkbox"/>
3	ELMGLADE FARMS LLC	PO BOX 968	COLBY	KS	67701	12/13/2016	1,312,500	2:WDC : 875	<input type="checkbox"/>	<input checked="" type="checkbox"/>

X:  TTO LISTER: JK DATE: 03/12/2019 TIME: 12:00:00 AM  LETTER  LETTER REC'D GIS CODE

STREET/ROAD	TOPOGRAPHY	PU-UTILITIES-PR	NEIGHBORHOOD	INFLUENCE FACTORS		PROPERTY LOCATION
<input type="checkbox"/> PAVED <input type="checkbox"/> GRAVEL <input type="checkbox"/> DIRT <input type="checkbox"/> SIDEWALKS <input type="checkbox"/> CURBS	<input type="checkbox"/> LEVEL <input type="checkbox"/> HIGH <input type="checkbox"/> LOW <input type="checkbox"/> ROLLING <input type="checkbox"/> STANDARD	<input type="checkbox"/> WATER <input type="checkbox"/> SEWER <input type="checkbox"/> GAS <input type="checkbox"/> ELECTRIC <input checked="" type="checkbox"/> STANDARD	<input type="checkbox"/> IMPROVING <input type="checkbox"/> STATIC <input type="checkbox"/> DECLINING <input type="checkbox"/> OLD <input type="checkbox"/> STANDARD	<input type="checkbox"/> A. NO ROAD <input type="checkbox"/> B. TOPGRHY <input type="checkbox"/> C. Ex Front <input type="checkbox"/> D. QUANTITY <input type="checkbox"/> E. SZ/SHAPE	<input type="checkbox"/> F. RESTRICT <input type="checkbox"/> G. WOOD LT <input type="checkbox"/> H. VACANCY <input type="checkbox"/> I. WATER FRONT <input type="checkbox"/> J. OTHER/CDU	7124 US RT 33, CELINA <b>COMMENT</b> Tax Incentive Exempt Parcel: 06-016800.010K (TY2022 L=0; B=5,692,570; T=5,692,570) TY2022:Net Gen=\$35,157.74, Other Assessment=\$96,815.16 DE19 ADD BLDG VALUE; 75% TIF DE18 LARGE DAIRY //CREATE TIF DISTRICT//started after 1/1/2017 DE21 INCR BARN LOT; ADJ LAND DE22 DESKTOP RVW; RVW OUTBDLGS 2017 DUPL BLDG VALUE: \$0 2020 DUPL BLDG VALUE: \$7,926,500 2022 DUPL BLDG VALUE: \$7,590,090 2023 DUPL BDLG VALUE: \$10,347,870 NC28 TIF EXPIRES TAX INCENTIVE: TIF512 TIF EXPIRES 2028TY/2019CY

LAND COMPUTATIONS						
LAND TYPE	SIZE	M	RATE	C	INF	M VALUE C
BL:Barn Lot	A 20.0000	10,000	10,000			200,000 200,000
<b>CR:Crop Land TOTAL</b>	<b>A 56.3970</b>	<b>11,750</b>	<b>2,920</b>			<b>677,910 179,290</b>
0024	A 15.2540	11,250	2,540			171,610 38,750
0087	A 34.5540	12,450	3,560			430,200 123,010
0023	A 6.5890	11,550	2,660			76,100 17,530
RD:Road	A .9970	0	0			0 0
<b>WO:Woods TOTAL</b>	<b>A .2430</b>	<b>6,410</b>	<b>1,160</b>			<b>1,630 350</b>
0087	A .1860	7,000	1,670			1,300 310
0024	A .0570	5,820	650			330 40
Total Acres: 77.6370					TOTAL	879,540 379,640

VALUATION SUMMARY									
VALUE YEAR	2023	2023	2022	2022	2021	2021	2020	2020	
REASON FOR CHANGE	CAUV	RAPP	CAUV	MISC	CAUV	MISC	CAUV	RAPP	
APPRAISED	LAND	379,640	879,540	194,870	617,300	194,870	617,300	138,250	702,420
VALUE	IMPR	2,586,900	2,586,900	1,936,100	1,936,100	1,981,400	1,981,400	1,981,400	1,981,400
	TOTAL	2,966,540	3,466,440	2,130,970	2,553,400	2,176,270	2,598,700	2,119,650	2,683,820
ASSESSED	LAND	132,870	307,840	68,200	216,060	68,200	216,060	48,390	245,850
VALUE	IMPR	905,420	905,420	677,640	677,640	693,490	693,490	693,490	693,490
	TOTAL	1,038,290	1,213,260	745,840	893,700	761,690	909,550	741,880	939,340
POTENTIAL RECOUP	2022=6969.89, 2021=6986.88, 2020=5904.56: Total=19861.33								

OCCUPANCY		EXTERIOR		FLOOR	AREA	CONST	VALUE	
<input type="checkbox"/> SF	<input type="checkbox"/> DU	<input type="checkbox"/> TR	<input type="checkbox"/> WOOD					
<input type="checkbox"/> CONVERSION			<input type="checkbox"/> STUCCO					
<b>BUILDING TYPE</b>								
<input type="checkbox"/> MOBILE HOME			<input type="checkbox"/> ALM/VYNL					
<input type="checkbox"/> BI/TR LEVEL			<input type="checkbox"/> CONC BLK					
<input type="checkbox"/> MOD/MAN			<input type="checkbox"/> METAL					
<input type="checkbox"/>			<input type="checkbox"/> BRICK					
			<input type="checkbox"/> STONE					
<b>ROOFING</b>		<b>ROOF TYPE</b>						
<input type="checkbox"/> METAL		<input type="checkbox"/> GABLE						
<input type="checkbox"/> SLT/TLE		<input type="checkbox"/> HIP						
<input type="checkbox"/> SHINGLES		<input type="checkbox"/> GAMBREL						
<input type="checkbox"/> SHAKES		<input type="checkbox"/> MANSARD						
<input type="checkbox"/> COMPOSITE		<input type="checkbox"/> FLAT						
<b>FLOORS</b>				B	1	2	3	U
CONCRETE		<input type="checkbox"/>	<input type="checkbox"/>	<input type="checkbox"/>	<input type="checkbox"/>	<input type="checkbox"/>	<input type="checkbox"/>	<input type="checkbox"/>
WOOD		<input type="checkbox"/>	<input type="checkbox"/>	<input type="checkbox"/>	<input type="checkbox"/>	<input type="checkbox"/>	<input type="checkbox"/>	<input type="checkbox"/>
TILE/COMPO		<input type="checkbox"/>	<input type="checkbox"/>	<input type="checkbox"/>	<input type="checkbox"/>	<input type="checkbox"/>	<input type="checkbox"/>	<input type="checkbox"/>
CARPET		<input type="checkbox"/>	<input type="checkbox"/>	<input type="checkbox"/>	<input type="checkbox"/>	<input type="checkbox"/>	<input type="checkbox"/>	<input type="checkbox"/>
<b>INT. FINISH</b>				B	1	2	3	U
PLASTER/DW		<input type="checkbox"/>	<input type="checkbox"/>	<input type="checkbox"/>	<input type="checkbox"/>	<input type="checkbox"/>	<input type="checkbox"/>	<input type="checkbox"/>
PANELING		<input type="checkbox"/>	<input type="checkbox"/>	<input type="checkbox"/>	<input type="checkbox"/>	<input type="checkbox"/>	<input type="checkbox"/>	<input type="checkbox"/>
UNFINISHED		<input type="checkbox"/>	<input type="checkbox"/>	<input type="checkbox"/>	<input type="checkbox"/>	<input type="checkbox"/>	<input type="checkbox"/>	<input type="checkbox"/>
<b>ACCOMMODATIONS</b>								
# OF ROOMS								
BEDROOMS								
FIREPLACES								
HEAT & AC		B	1	2	3	U		
NO HEAT		<input type="checkbox"/>	<input type="checkbox"/>	<input type="checkbox"/>	<input type="checkbox"/>	<input type="checkbox"/>	<input type="checkbox"/>	<input type="checkbox"/>
CTRL HEAT		<input type="checkbox"/>	<input type="checkbox"/>	<input type="checkbox"/>	<input type="checkbox"/>	<input type="checkbox"/>	<input type="checkbox"/>	<input type="checkbox"/>
HW/STEAM		<input type="checkbox"/>	<input type="checkbox"/>	<input type="checkbox"/>	<input type="checkbox"/>	<input type="checkbox"/>	<input type="checkbox"/>	<input type="checkbox"/>
ELECTRIC		<input type="checkbox"/>	<input type="checkbox"/>	<input type="checkbox"/>	<input type="checkbox"/>	<input type="checkbox"/>	<input type="checkbox"/>	<input type="checkbox"/>
HEAT PUMP		<input type="checkbox"/>	<input type="checkbox"/>	<input type="checkbox"/>	<input type="checkbox"/>	<input type="checkbox"/>	<input type="checkbox"/>	<input type="checkbox"/>
FLR/WALL		<input type="checkbox"/>	<input type="checkbox"/>	<input type="checkbox"/>	<input type="checkbox"/>	<input type="checkbox"/>	<input type="checkbox"/>	<input type="checkbox"/>
STVE/SPCE		<input type="checkbox"/>	<input type="checkbox"/>	<input type="checkbox"/>	<input type="checkbox"/>	<input type="checkbox"/>	<input type="checkbox"/>	<input type="checkbox"/>
GEOTHERMAL		<input type="checkbox"/>	<input type="checkbox"/>	<input type="checkbox"/>	<input type="checkbox"/>	<input type="checkbox"/>	<input type="checkbox"/>	<input type="checkbox"/>
OUTSIDE		<input type="checkbox"/>	<input type="checkbox"/>	<input type="checkbox"/>	<input type="checkbox"/>	<input type="checkbox"/>	<input type="checkbox"/>	<input type="checkbox"/>
CTRL A/C		<input type="checkbox"/>	<input type="checkbox"/>	<input type="checkbox"/>	<input type="checkbox"/>	<input type="checkbox"/>	<input type="checkbox"/>	<input type="checkbox"/>
<b>PLUMBING</b>		BASE		<input type="checkbox"/>				
X FULL BATH								
X HALF BATH								
X FIXTURES								
<b>SUBTOTAL</b>							0	
MULTI-FAMILY #				0			0	
BUILDING TYPE				000%			0	
BSMT FINISH				0 S.F.			0	
FIREPLACE #				0			0	
HEATING				0 S.F.			0	
AIR COND				0 S.F.			0	
PLUMBING #				0			0	
GARAGES & CARPORTS							0	
EXTRA FEATURES							0	
<b>SUBTOTAL</b>							0	
GRADE FACTOR							%	
<b>UNADJUSTED VALUE</b>							0	
FACTOR							%	

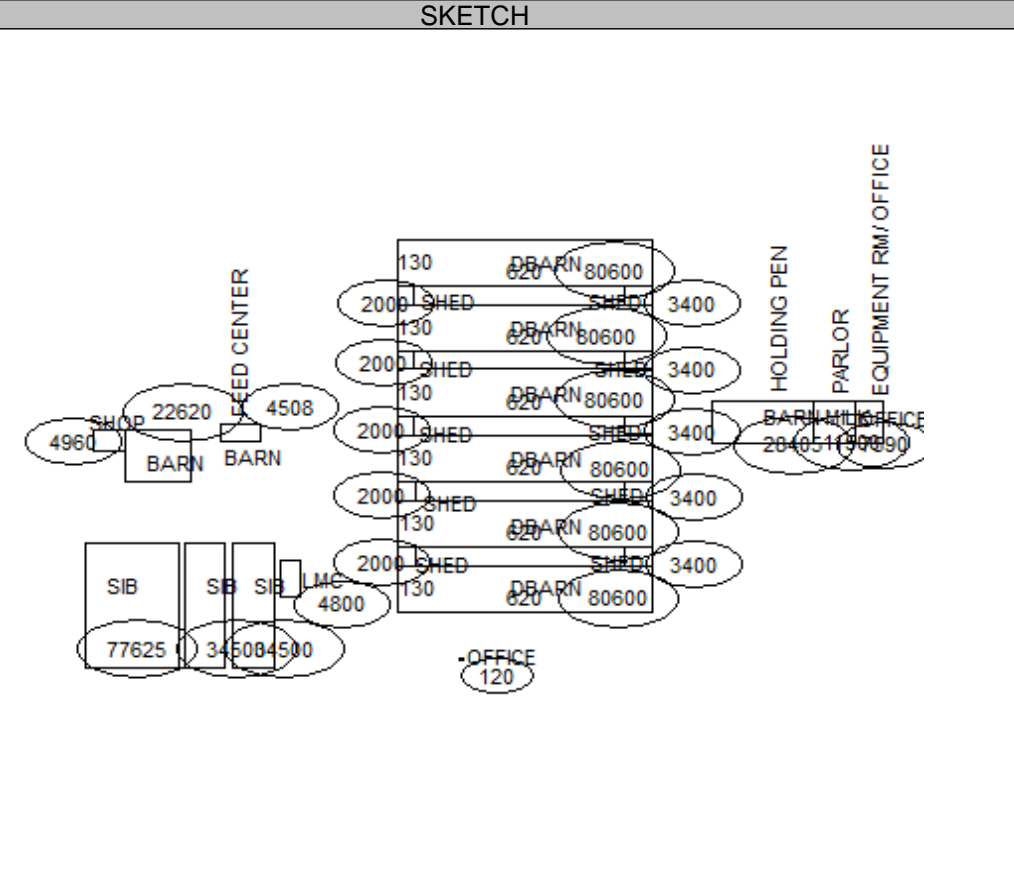

OCCUPANCY	ST.HT	SIZE	AREA	GRADE	PRICE	AGE	REMD	CND	UNADJ VAL	PHYS	PHYS VAL	FUNC	TRUE VAL
DWELLING		SK											
1 Barn-Dairy		130x620	80,600	C	19.50	2018		A	1,571,700	5	1,493,120	TIF75	373,300
2 Barn-Dairy		130x620	80,600	C	19.50	2018		A	1,571,700	5	1,493,120	TIF75	373,300
3 Barn-Dairy		130x620	80,600	C	19.50	2018		A	1,571,700	5	1,493,120	TIF75	373,300
4 Barn-Dairy		130x620	80,600	C	19.50	2018		A	1,571,700	5	1,493,120	TIF75	373,300
5 Barn-Dairy		130x620	80,600	C	19.50	2018		A	1,571,700	5	1,493,120	TIF75	373,300
6 Barn-Dairy		130x620	80,600	C	19.50	2018		A	1,571,700	5	1,493,120	TIF75	373,300
7 Barn		115x247	28,405	C	12.00	2018		A	340,860	5	323,820	TIF75	81,000
8 Milk House / Par		115x100	11,500	C	18.00	2018		A	207,000	5	196,650	TIF75	49,200
9 Office	24	115x66	7,590	C	38.50	2018		A	292,220	5	277,610	TIF75	69,400
10 Barn		46x98	4,508	C	12.00	2018		A	54,100	5	51,400	TIF75	12,900
11 Silo - Bunker		345x225	77,625	C	550.00	2018		A	550		550	TIF75	100

06-016800.0100

TOTAL 2,452,400

COMMENTS



OCCUPANCY		EXTERIOR		FLOOR	AREA	CONST	VALUE
<input type="checkbox"/> SF	<input type="checkbox"/> DU	<input type="checkbox"/> TR	<input type="checkbox"/> WOOD				
<input type="checkbox"/> CONVERSION			<input type="checkbox"/> STUCCO				
<b>BUILDING TYPE</b>			<input type="checkbox"/> ALM/VYNL				
<input type="checkbox"/> MOBILE HOME			<input type="checkbox"/> CONC BLK				
<input type="checkbox"/> BI/TR LEVEL			<input type="checkbox"/> METAL				
<input type="checkbox"/> MOD/MAN			<input type="checkbox"/> BRICK				
<input type="checkbox"/>			<input type="checkbox"/> STONE				
ROOFING		ROOF TYPE					
<input type="checkbox"/> METAL		<input type="checkbox"/> GABLE					
<input type="checkbox"/> SLT/TLE		<input type="checkbox"/> HIP					
<input type="checkbox"/> SHINGLES		<input type="checkbox"/> GAMBREL					
<input type="checkbox"/> SHAKES		<input type="checkbox"/> MANSARD					
<input type="checkbox"/> COMPOSITE		<input type="checkbox"/> FLAT					
FLOORS		B	1	2	3	U	
CONCRETE		<input type="checkbox"/>	<input type="checkbox"/>	<input type="checkbox"/>	<input type="checkbox"/>	<input type="checkbox"/>	
WOOD		<input type="checkbox"/>	<input type="checkbox"/>	<input type="checkbox"/>	<input type="checkbox"/>	<input type="checkbox"/>	
TILE/COMPO		<input type="checkbox"/>	<input type="checkbox"/>	<input type="checkbox"/>	<input type="checkbox"/>	<input type="checkbox"/>	
CARPET		<input type="checkbox"/>	<input type="checkbox"/>	<input type="checkbox"/>	<input type="checkbox"/>	<input type="checkbox"/>	
INT. FINISH		B	1	2	3	U	
PLASTER/DW		<input type="checkbox"/>	<input type="checkbox"/>	<input type="checkbox"/>	<input type="checkbox"/>	<input type="checkbox"/>	
PANELING		<input type="checkbox"/>	<input type="checkbox"/>	<input type="checkbox"/>	<input type="checkbox"/>	<input type="checkbox"/>	
UNFINISHED		<input type="checkbox"/>	<input type="checkbox"/>	<input type="checkbox"/>	<input type="checkbox"/>	<input type="checkbox"/>	
ACCOMMODATIONS							
# OF ROOMS							
BEDROOMS							
FIREPLACES							
HEAT & AC		B	1	2	3	U	
NO HEAT		<input type="checkbox"/>	<input type="checkbox"/>	<input type="checkbox"/>	<input type="checkbox"/>	<input type="checkbox"/>	
CTRL HEAT		<input type="checkbox"/>	<input type="checkbox"/>	<input type="checkbox"/>	<input type="checkbox"/>	<input type="checkbox"/>	
HW/STEAM		<input type="checkbox"/>	<input type="checkbox"/>	<input type="checkbox"/>	<input type="checkbox"/>	<input type="checkbox"/>	
ELECTRIC		<input type="checkbox"/>	<input type="checkbox"/>	<input type="checkbox"/>	<input type="checkbox"/>	<input type="checkbox"/>	
HEAT PUMP		<input type="checkbox"/>	<input type="checkbox"/>	<input type="checkbox"/>	<input type="checkbox"/>	<input type="checkbox"/>	
FLR/WALL		<input type="checkbox"/>	<input type="checkbox"/>	<input type="checkbox"/>	<input type="checkbox"/>	<input type="checkbox"/>	
STVE/SPCE		<input type="checkbox"/>	<input type="checkbox"/>	<input type="checkbox"/>	<input type="checkbox"/>	<input type="checkbox"/>	
GEOTHERMAL		<input type="checkbox"/>	<input type="checkbox"/>	<input type="checkbox"/>	<input type="checkbox"/>	<input type="checkbox"/>	
OUTSIDE		<input type="checkbox"/>	<input type="checkbox"/>	<input type="checkbox"/>	<input type="checkbox"/>	<input type="checkbox"/>	
CTRL A/C		<input type="checkbox"/>	<input type="checkbox"/>	<input type="checkbox"/>	<input type="checkbox"/>	<input type="checkbox"/>	
<b>PLUMBING</b>		<b>BASE</b>		<input type="checkbox"/>			
X FULL BATH							
X HALF BATH							
X FIXTURES							
<b>SUBTOTAL</b>							0
MULTI-FAMILY #				0			0
BUILDING TYPE				000%			0
BSMT FINISH				0 S.F.			0
FIREPLACE #				0			0
HEATING				0 S.F.			0
AIR COND				0 S.F.			0
PLUMBING #				0			0
GARAGES & CARPORTS							0
EXTRA FEATURES							0
<b>SUBTOTAL</b>							0
GRADE FACTOR							%
<b>UNADJUSTED VALUE</b>							0
FACTOR							%

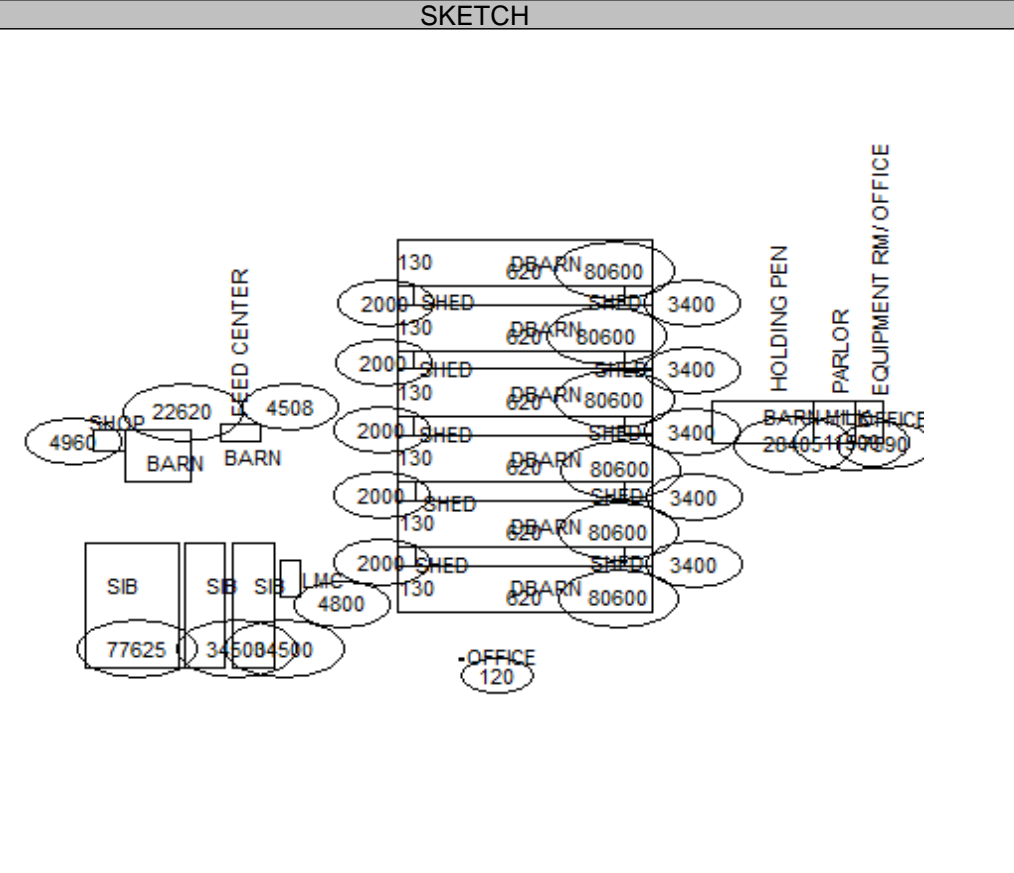

OCCUPANCY	ST.HT	SIZE	AREA	GRADE	PRICE	AGE	REMD	CND	UNADJ VAL	PHYS	PHYS VAL	FUNC	TRUE VAL
DWELLING		SK											
1 Silo - Bunker		345x100	34,500	C	550.00	2018		A	550		550	TIF75	100
2 Silo - Bunker		345x100	34,500	C	550.00	2018		A	550		550	TIF75	100
3 Shed		50x68	3,400	C	7.10	2018		A	24,140	5	22,930	TIF75	5,700
4 Shed		50x40	2,000	C	4.40	2018		A	8,800	5	8,360	TIF75	2,100
5 Shed		50x68	3,400	C	7.10	2018		A	24,140	5	22,930	TIF75	5,700
6 Shed		50x68	3,400	C	7.10	2018		A	24,140	5	22,930	TIF75	5,700
7 Shed		50x40	2,000	C	4.40	2018		A	8,800	5	8,360	TIF75	2,100
8 Shed		50x40	2,000	C	4.40	2018		A	8,800	5	8,360	TIF75	2,100
9 Shed		50x40	2,000	C	4.40	2018		A	8,800	5	8,360	TIF75	2,100
10 Shed		50x68	3,400	C	7.10	2018		A	24,140	5	22,930	TIF75	5,700
11 Shed		50x40	2,000	C	4.40	2018		A	8,800	5	8,360	TIF75	2,100

06-016800.0100

TOTAL 33,500

COMMENTS



OCCUPANCY	EXTERIOR	FLOOR	AREA	CONST	VALUE
<input type="checkbox"/> SF <input type="checkbox"/> DU <input type="checkbox"/> TR	<input type="checkbox"/> WOOD				
<input type="checkbox"/> CONVERSION	<input type="checkbox"/> STUCCO				
<b>BUILDING TYPE</b>	<input type="checkbox"/> ALM/VYNL				
<input type="checkbox"/> MOBILE HOME	<input type="checkbox"/> CONC BLK				
<input type="checkbox"/> BI/TR LEVEL	<input type="checkbox"/> METAL				
<input type="checkbox"/> MOD/MAN	<input type="checkbox"/> BRICK				
<input type="checkbox"/>	<input type="checkbox"/> STONE				

ROOFING	ROOF TYPE
<input type="checkbox"/> METAL	<input type="checkbox"/> GABLE
<input type="checkbox"/> SLT/TLE	<input type="checkbox"/> HIP
<input type="checkbox"/> SHINGLES	<input type="checkbox"/> GAMBREL
<input type="checkbox"/> SHAKES	<input type="checkbox"/> MANSARD
<input type="checkbox"/> COMPOSITE	<input type="checkbox"/> FLAT

FLOORS	B	1	2	3	U
CONCRETE	<input type="checkbox"/>	<input type="checkbox"/>	<input type="checkbox"/>	<input type="checkbox"/>	<input type="checkbox"/>
WOOD	<input type="checkbox"/>	<input type="checkbox"/>	<input type="checkbox"/>	<input type="checkbox"/>	<input type="checkbox"/>
TILE/COMPO	<input type="checkbox"/>	<input type="checkbox"/>	<input type="checkbox"/>	<input type="checkbox"/>	<input type="checkbox"/>
CARPET	<input type="checkbox"/>	<input type="checkbox"/>	<input type="checkbox"/>	<input type="checkbox"/>	<input type="checkbox"/>
INT. FINISH	B	1	2	3	U
PLASTER/DW	<input type="checkbox"/>	<input type="checkbox"/>	<input type="checkbox"/>	<input type="checkbox"/>	<input type="checkbox"/>
PANELING	<input type="checkbox"/>	<input type="checkbox"/>	<input type="checkbox"/>	<input type="checkbox"/>	<input type="checkbox"/>
UNFINISHED	<input type="checkbox"/>	<input type="checkbox"/>	<input type="checkbox"/>	<input type="checkbox"/>	<input type="checkbox"/>
ACCOMMODATIONS					
# OF ROOMS					
BEDROOMS					
FIREPLACES					
HEAT & AC	B	1	2	3	U
NO HEAT	<input type="checkbox"/>	<input type="checkbox"/>	<input type="checkbox"/>	<input type="checkbox"/>	<input type="checkbox"/>
CTRL HEAT	<input type="checkbox"/>	<input type="checkbox"/>	<input type="checkbox"/>	<input type="checkbox"/>	<input type="checkbox"/>
HW/STEAM	<input type="checkbox"/>	<input type="checkbox"/>	<input type="checkbox"/>	<input type="checkbox"/>	<input type="checkbox"/>
ELECTRIC	<input type="checkbox"/>	<input type="checkbox"/>	<input type="checkbox"/>	<input type="checkbox"/>	<input type="checkbox"/>
HEAT PUMP	<input type="checkbox"/>	<input type="checkbox"/>	<input type="checkbox"/>	<input type="checkbox"/>	<input type="checkbox"/>
FLR/WALL	<input type="checkbox"/>	<input type="checkbox"/>	<input type="checkbox"/>	<input type="checkbox"/>	<input type="checkbox"/>
STVE/SPCE	<input type="checkbox"/>	<input type="checkbox"/>	<input type="checkbox"/>	<input type="checkbox"/>	<input type="checkbox"/>
GEOTHERMAL	<input type="checkbox"/>	<input type="checkbox"/>	<input type="checkbox"/>	<input type="checkbox"/>	<input type="checkbox"/>
OUTSIDE	<input type="checkbox"/>	<input type="checkbox"/>	<input type="checkbox"/>	<input type="checkbox"/>	<input type="checkbox"/>
CTRL A/C	<input type="checkbox"/>	<input type="checkbox"/>	<input type="checkbox"/>	<input type="checkbox"/>	<input type="checkbox"/>
PLUMBING					
X FULL BATH					
X HALF BATH					
X FIXTURES					

<b>SUBTOTAL</b>		0
MULTI-FAMILY #	0	0
BUILDING TYPE	000%	0
BSMT FINISH	0 S.F.	0
FIREPLACE #	0	0
HEATING	0 S.F.	0
AIR COND	0 S.F.	0
PLUMBING #	0	0
GARAGES & CARPORTS		0
EXTRA FEATURES		0
<b>SUBTOTAL</b>		0
GRADE FACTOR		%
<b>UNADJUSTED VALUE</b>		0
FACTOR		%

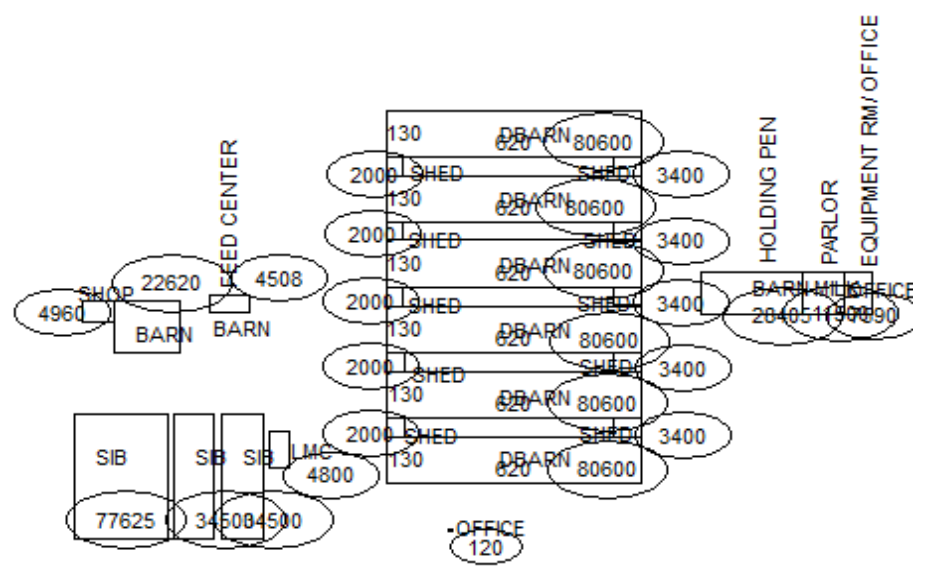

OCCUPANCY	ST.HT	SIZE	AREA	GRADE	PRICE	AGE	REMD	CND	UNADJ VAL	PHYS	PHYS VAL	FUNC	TRUE VAL
DWELLING		SK											
1 Shed		50x68	3,400	C	7.10	2018		A	24,140	5	22,930	TIF75	5,700
2 Lot/ Manure Cover		100x48	4,800	C	10.51	2020		A	50,450	3	48,940	TIF75	12,200
3 Barn		145x156	22,620	C	12.00	2020		A	271,440	3	263,300	TIF75	65,800
4 Shop - Stud		62x80	4,960	C	13.75	2020		A	68,200	3	66,150	TIF75	16,500
5 Office		10x12	120	D	30.80	2018		F	3,700	14	3,180	TIF75	800
6													
7													
8													
9													
10													
11													

06-016800.0100

TOTAL 101,000

COMMENTS