

CENTER TWP / CELINA SD

06-06-400-002

Property Class: 510

Neighborhood

009065-R150

Map: 04

Block:

Card: 03

Bk: Pg:

06-012400.0200

LAUX BENJAMIN R & SARA K

LAUX BENJAMIN R & SARA K

6387 HASIS RD

CELINA, OH 45822

LEGAL INFORMATION

PT SW SE

RTS: 003-05-06

Acres:4.0000

	OWNERSHIP	ADDRESS	CITY	STATE	ZIP	DATE	AMOUNT	DEED:CONV#	JS	VALID
1	LAUX BENJAMIN R & SARA K	6387 HASIS RD	CELINA	OH	45822	04/24/2017	280,000	FDC : 245	<input type="checkbox"/>	<input checked="" type="checkbox"/>
2	BOWLBY JANICE E	6387 HASIS RD	CELINA	OH	45822	02/07/2006	0	QCE : X : 0	<input type="checkbox"/>	<input type="checkbox"/>
3	BOWLBY CLARENCE A &	8165 RICE RD	CELINA	OH	45822	11/02/1990	77,000	: A : 0	<input type="checkbox"/>	<input checked="" type="checkbox"/>

X: TTO LISTER: ss DATE: 06/25/2007 TIME: 12:00:00 AM LETTER LETTER REC'D GIS CODE

STREET/ROAD TOPOGRAPHY PU-UTILITIES-PR NEIGHBORHOOD INFLUENCE FACTORS PROPERTY LOCATION

PAVED LEVEL WATER IMPROVING A. NO ROAD F. RESTRICT 6387 HASIS RD
 GRAVEL HIGH SEWER STATIC B. TOPGRHY G. WOOD LT
 DIRT LOW GAS DECLINING C. Ex Front H. VACANCY
 SIDEWALKS ROLLING ELECTRIC OLD D. QUANTITY I. WATER FRONT
 CURBS STANDARD STANDARD STANDARD E. SZ/SHAPE J. OTHER/CDU

COMMENT

TY2022:Net Gen=\$4,084.38, Other Assessment=\$2.00
 DE07 rmv 2nd FP- FP never finished in bsmnt per owner
 DE06 hse finished/corrected on 2nd half
 DE18 REMOVE OWN OCC didn't return app
 DE19 OWNER CAME IN FILLED OUT OCC
 TTO DE15 RMV GB VALUE PER ODT

LAND COMPUTATIONS

LAND TYPE	SIZE	M	RATE	C	INF	M	VALUE	C
HS:Home Site	AC:1	18150				18,200	0	
SM:Small Acreage	AC:3	8100				24,300	0	
Total Acres: 4.0000						TOTAL	42,500	0

VALUATION SUMMARY

VALUE YEAR	2023	2020	2017	2017	2017	2017	2017
REASON FOR CHANGE	RAPP	RAPP	RAPP	MISC	RCLS	CAUV	MISC
APPRAISED VALUE	LAND 42,500	40,000	36,300	36,900	42,550	25,320	40,140
	IMPR 344,500	212,100	199,000	200,700	200,700	200,700	200,700
	TOTAL 387,000	252,100	235,300	237,600	243,250	226,020	240,840
ASSESSED VALUE	LAND 14,880	14,000	12,710	12,920	14,890	8,860	14,050
	IMPR 120,580	74,240	69,650	70,250	70,250	70,250	70,250
	TOTAL 135,460	88,240	82,360	83,170	85,140	79,110	84,300

OCCUPANCY		EXTERIOR		FLOOR	AREA	CONST	VALUE
<input checked="" type="checkbox"/> SF	<input type="checkbox"/> DU	<input type="checkbox"/> TR	<input type="checkbox"/> WOOD	1	1989	BRK	251,310
<input type="checkbox"/> CONVERSION			<input type="checkbox"/> STUCCO	.25	239	BRK	27,510
BUILDING TYPE							
<input type="checkbox"/> MOBILE HOME			<input type="checkbox"/> ALM/VYNL				
<input type="checkbox"/> BI/TR LEVEL			<input type="checkbox"/> CONC BLK				
<input type="checkbox"/> MOD/MAN			<input type="checkbox"/> METAL				
<input type="checkbox"/>			<input checked="" type="checkbox"/> BRICK				
			<input type="checkbox"/> STONE				
ROOFING		ROOF TYPE					
<input type="checkbox"/> METAL			<input checked="" type="checkbox"/> GABLE				
<input type="checkbox"/> SLT/TLE			<input type="checkbox"/> HIP				
<input checked="" type="checkbox"/> SHINGLES			<input type="checkbox"/> GAMBREL				
<input type="checkbox"/> SHAKES			<input type="checkbox"/> MANSARD				
<input type="checkbox"/> COMPOSITE			<input type="checkbox"/> FLAT				
FLOORS		B	1	2	3	U	
CONCRETE	<input checked="" type="checkbox"/>	<input type="checkbox"/>	<input type="checkbox"/>	<input type="checkbox"/>	<input type="checkbox"/>	<input type="checkbox"/>	
WOOD	<input type="checkbox"/>	<input type="checkbox"/>	<input type="checkbox"/>	<input type="checkbox"/>	<input type="checkbox"/>	<input type="checkbox"/>	
TILE/COMPO	<input type="checkbox"/>	<input type="checkbox"/>	<input type="checkbox"/>	<input type="checkbox"/>	<input type="checkbox"/>	<input type="checkbox"/>	
CARPET	<input type="checkbox"/>	<input type="checkbox"/>	<input type="checkbox"/>	<input type="checkbox"/>	<input type="checkbox"/>	<input type="checkbox"/>	
INT. FINISH		B	1	2	3	U	
PLASTER/DW	<input type="checkbox"/>	<input checked="" type="checkbox"/>	<input checked="" type="checkbox"/>	<input type="checkbox"/>	<input type="checkbox"/>	<input type="checkbox"/>	
PANELING	<input type="checkbox"/>	<input type="checkbox"/>	<input type="checkbox"/>	<input type="checkbox"/>	<input type="checkbox"/>	<input type="checkbox"/>	
UNFINISHED	<input checked="" type="checkbox"/>	<input type="checkbox"/>	<input type="checkbox"/>	<input type="checkbox"/>	<input type="checkbox"/>	<input type="checkbox"/>	
ACCOMMODATIONS							
# OF ROOMS		7	2				
BEDROOMS		2	2				
FIREPLACES		1					
HEAT & AC		B	1	2	3	U	
NO HEAT	<input type="checkbox"/>	<input type="checkbox"/>	<input type="checkbox"/>	<input type="checkbox"/>	<input type="checkbox"/>	<input type="checkbox"/>	
CTRL HEAT	<input type="checkbox"/>	<input type="checkbox"/>	<input checked="" type="checkbox"/>	<input type="checkbox"/>	<input type="checkbox"/>	<input type="checkbox"/>	
HW/STEAM	<input type="checkbox"/>	<input type="checkbox"/>	<input type="checkbox"/>	<input type="checkbox"/>	<input type="checkbox"/>	<input type="checkbox"/>	
ELECTRIC	<input type="checkbox"/>	<input type="checkbox"/>	<input type="checkbox"/>	<input type="checkbox"/>	<input type="checkbox"/>	<input type="checkbox"/>	
HEAT PUMP	<input type="checkbox"/>	<input type="checkbox"/>	<input type="checkbox"/>	<input type="checkbox"/>	<input type="checkbox"/>	<input type="checkbox"/>	
FLR/WALL	<input type="checkbox"/>	<input type="checkbox"/>	<input type="checkbox"/>	<input type="checkbox"/>	<input type="checkbox"/>	<input type="checkbox"/>	
STVE/SPCE	<input type="checkbox"/>	<input type="checkbox"/>	<input type="checkbox"/>	<input type="checkbox"/>	<input type="checkbox"/>	<input type="checkbox"/>	
GEOHERMAL	<input type="checkbox"/>	<input type="checkbox"/>	<input type="checkbox"/>	<input type="checkbox"/>	<input type="checkbox"/>	<input type="checkbox"/>	
OUTSIDE	<input type="checkbox"/>	<input type="checkbox"/>	<input type="checkbox"/>	<input type="checkbox"/>	<input type="checkbox"/>	<input type="checkbox"/>	
CTRL A/C	<input type="checkbox"/>	<input type="checkbox"/>	<input type="checkbox"/>	<input type="checkbox"/>	<input type="checkbox"/>	<input type="checkbox"/>	
PLUMBING		BASE		<input checked="" type="checkbox"/>			
X FULL BATH			1				
X HALF BATH		1					
X FIXTURES							
		BSMT	955				13,660
		SUBTOTAL					292,480
		MULTI-FAMILY #	0				0
		BUILDING TYPE	100%				0
		BSMT FINISH	0 S.F.				0
		FIREPLACE #	1				4,400
		HEATING	0 S.F.				0
		AIR COND	0 S.F.				0
		PLUMBING #	5				6,050
		GARAGES & CARPORTS					21,700
		EXTRA FEATURES					3,400
		SUBTOTAL					328,030
		GRADE FACTOR					115 %
		UNADJUSTED VALUE					377,230
		FACTOR					100 %

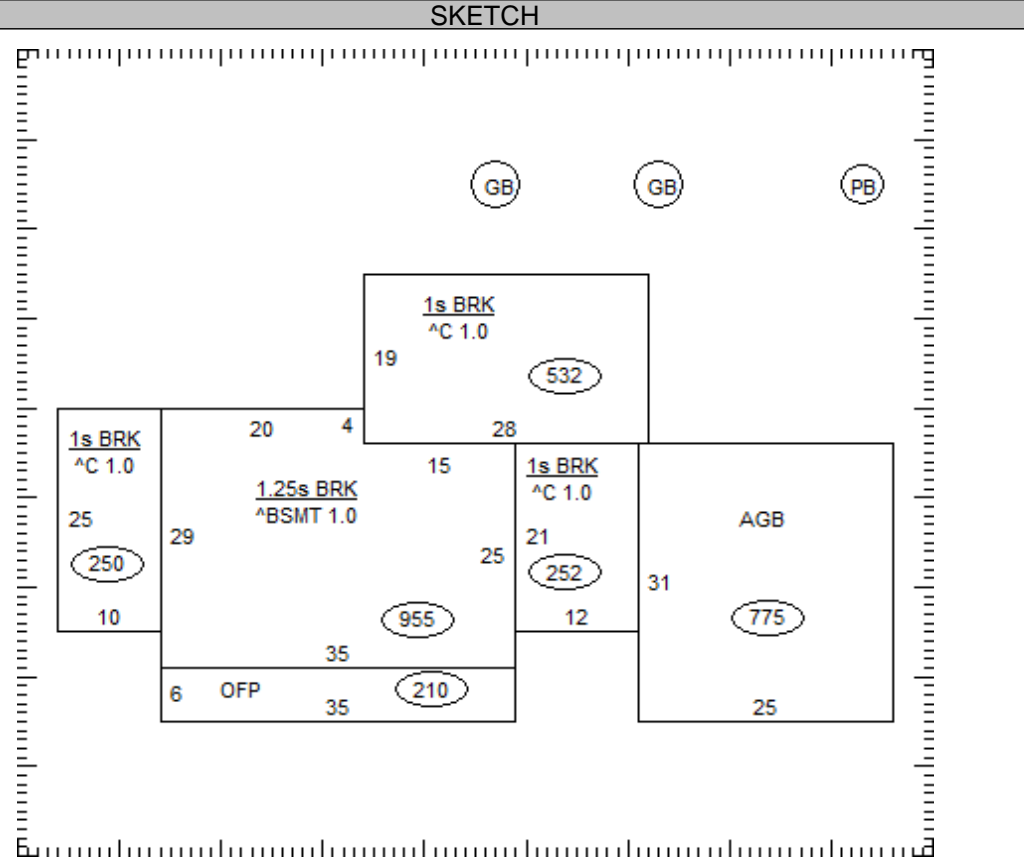

OCCUPANCY	ST.HT	SIZE	AREA	GRADE	PRICE	AGE	REMD	CND	UNADJ VAL	PHYS	PHYS VAL	FUNC	TRUE VAL
DWELLING	1.25	SK	2,228	B-		2000		A	377,230	19	305,560		320,800
1 Grain Bin	15	15x24	360	C		1996		A		47			0
2 Grain Bin	15	15x18	270	C		1994		A		47			0
3 Pole Bldg	14	48x80	3,840	C	11.62	1993		A	44,620	47	23,650		23,700
4													
5													
6													
7													
8													
9													
10													
11													

06-012400.0200

TOTAL 344,500

COMMENTS

>>OB Features: 1.3 <Add 1/4 Concrete Floor>
 Dwelling has an Economic Factor of 105% (Rollback Basis=\$339,000)