

BUTLER TWP-COLDWATER CORP / COLDWATER SD
08-27-178-005

05-225000.0000

OBRINGER BRENT M & AMANDA S
OBRINGER BRENT M & AMANDA S
1010 TERRACE AVE
COLDWATER, OH 45828
Created in 2005 From 05-004120.0000 due to Split

LEGAL INFORMATION
EASTPOINT ESTATES
FIRST ADDITION
LOT 1574

	OWNERSHIP	ADDRESS	CITY	STATE	ZIP	DATE	AMOUNT	DEED:CONV#	JS	VALID
1	OBRINGER BRENT M &	1010 TERRACE AVE	COLDWATER	OH	45828	01/27/2023	0	QCE : X : 0	<input type="checkbox"/>	<input type="checkbox"/>
2	OBRINGER BRENT M	1010 N TERRACE AVE	COLDWATER	OH	45828	03/18/2016	25,000	WDC : 162	<input type="checkbox"/>	<input checked="" type="checkbox"/>
3	JACKSON MARK H & DEE A	1008 TERRACE AVE	COLDWATER	OH	45828	03/21/2006	63,000	WDC : A-M : 209	<input type="checkbox"/>	<input type="checkbox"/>

X: TTO LISTER: HK DATE: 05/05/2020 TIME: 12:00:00 AM LETTER LETTER REC'D GIS CODE

STREET/ROAD TOPOGRAPHY PU-UTILITIES-PR NEIGHBORHOOD INFLUENCE FACTORS PROPERTY LOCATION

STREET/ROAD	TOPOGRAPHY	PU-UTILITIES-PR	NEIGHBORHOOD	INFLUENCE FACTORS		PROPERTY LOCATION
<input type="checkbox"/> PAVED <input type="checkbox"/> GRAVEL <input type="checkbox"/> DIRT <input type="checkbox"/> SIDEWALKS <input type="checkbox"/> CURBS	<input type="checkbox"/> LEVEL <input type="checkbox"/> HIGH <input type="checkbox"/> LOW <input type="checkbox"/> ROLLING <input type="checkbox"/> STANDARD	<input type="checkbox"/> WATER <input type="checkbox"/> SEWER <input type="checkbox"/> GAS <input type="checkbox"/> ELECTRIC <input type="checkbox"/> STANDARD	<input type="checkbox"/> IMPROVING <input type="checkbox"/> STATIC <input type="checkbox"/> DECLINING <input type="checkbox"/> OLD <input type="checkbox"/> STANDARD	<input type="checkbox"/> A. NO ROAD <input type="checkbox"/> B. TOPGRHY <input type="checkbox"/> C. Ex Front <input type="checkbox"/> D. QUANTITY <input type="checkbox"/> E. SZ/SHAPE	<input type="checkbox"/> F. RESTRICT <input type="checkbox"/> G. WOOD LT <input type="checkbox"/> H. VACANCY <input type="checkbox"/> I. WATER FRONT <input type="checkbox"/> J. OTHER/CDU	1010 TERRACE AVE

COMMENT
TY2022:Net Gen=\$3,461.26, Other
Assessment=\$0.00
DE20 NOH; APPEARS COMPL
DE19 NOH; ADD DWLG; EST 50% COMPL

LAND COMPUTATIONS

LAND TYPE	SIZE	M	RATE	C	INF	M	VALUE	C
F:Front	F87 D132	ST535	DP94	ADJ503			43,800	0
TOTAL							43,800	0

VALUATION SUMMARY

VALUE YEAR	2023	2020	2020	2019	2019	2017		
REASON FOR CHANGE	RAPP	RAPP	NC	RCLS	NC	RAPP		
APPRAISED	<u>LAND</u>	43,800	33,800	30,700	30,700	30,700	23,000	
VALUE	<u>IMPR</u>	316,300	235,400	206,400	103,200	103,200	0	
	<u>TOTAL</u>	360,100	269,200	237,100	133,900	133,900	23,000	
ASSESSED	<u>LAND</u>	15,330	11,830	10,750	10,750	10,750	8,050	
VALUE	<u>IMPR</u>	110,710	82,390	72,240	36,120	36,120	0	
	<u>TOTAL</u>	126,040	94,220	82,990	46,870	46,870	8,050	

OCCUPANCY		EXTERIOR		FLOOR	AREA	CONST	VALUE
<input checked="" type="checkbox"/> SF	<input type="checkbox"/> DU	<input type="checkbox"/> TR	<input type="checkbox"/> WOOD	1	1878	FR	226,960
<input type="checkbox"/> CONVERSION		<input type="checkbox"/> STUCCO					
BUILDING TYPE		<input checked="" type="checkbox"/> ALM/VYNL					
<input type="checkbox"/> MOBILE HOME		<input type="checkbox"/> CONC BLK					
<input type="checkbox"/> BI/TR LEVEL		<input type="checkbox"/> METAL					
<input type="checkbox"/> MOD/MAN		<input type="checkbox"/> BRICK					
<input type="checkbox"/>		<input checked="" type="checkbox"/> STONE					

ROOFING		ROOF TYPE	
<input type="checkbox"/> METAL		<input type="checkbox"/> GABLE	
<input type="checkbox"/> SLT/TLE		<input checked="" type="checkbox"/> HIP	
<input checked="" type="checkbox"/> SHINGLES		<input type="checkbox"/> GAMBREL	
<input type="checkbox"/> SHAKES		<input type="checkbox"/> MANSARD	
<input type="checkbox"/> COMPOSITE		<input type="checkbox"/> FLAT	

BSMT		1878	26,860
SUBTOTAL			253,820
MULTI-FAMILY #		0	0
BUILDING TYPE		100%	0
BSMT FINISH		0 S.F.	0
FIREPLACE #		0	0
HEATING		0 S.F.	0
AIR COND		1,878 S.F.	3,100
PLUMBING #		3	3,630
GARAGES & CARPORTS			18,200
EXTRA FEATURES			3,600
SUBTOTAL			282,350
GRADE FACTOR			105 %
UNADJUSTED VALUE			296,470
FACTOR			100 %

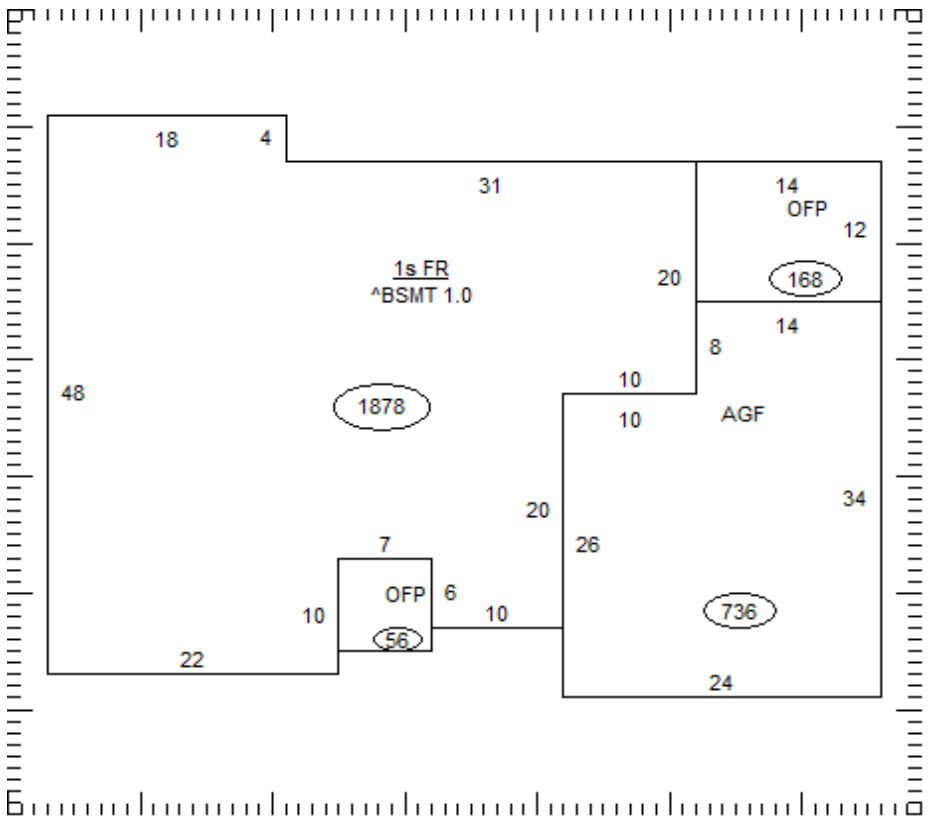

ACCOMMODATIONS		B	1	2	3	U								OCCUPANCY				ST.HT	SIZE	AREA	GRADE	PRICE	AGE	REMD	CND	UNADJ VAL	PHYS	PHYS VAL	FUNC	TRUE VAL					
# OF ROOMS			8											DWELLING	1	SK	1,878	C+		2018		G	296,470	3	287,580		316,300								
BEDROOMS			3											1																					
FIREPLACES														2																					
HEAT & AC														3																					
NO HEAT														4																					
CTRL HEAT														5																					
HW/STEAM														6																					
ELECTRIC														7																					
HEAT PUMP														8																					
FLR/WALL														9																					
STVE/SPCE														10																					
GEOHERMAL														11																					
OUTSIDE																																			
CTRL A/C																																			
PLUMBING																																			
X FULL BATH			1																																
X HALF BATH																																			
X FIXTURES																																			

05-225000.0000

TOTAL 316,300

COMMENTS

Dwelling has an Economic Factor of 110%

BUTLER TWP-COLDWATER CORP / COLDWATER SD
08-27-178-005

Property Class: 510

Neighborhood
000509-TS70

Map:
Block:
Card:

Bk: Pg:

05-225000.0000

OBRINGER BRENT M & AMANDA S
OBRINGER BRENT M & AMANDA S
1010 TERRACE AVE
COLDWATER, OH 45828

LEGAL INFORMATION
EASTPOINT ESTATES
FIRST ADDITION
LOT 1574

Created in 2005 From 05-004120.0000 due to Split

	OWNERSHIP	ADDRESS	CITY	STATE	ZIP	DATE	AMOUNT	DEED:CONV#	JS	VALID
1	RESTFUL ACRES INC	PO BOX 114	COLDWATER	OH	45828	10/26/2005	0	: 0	<input type="checkbox"/>	<input type="checkbox"/>
2							0	0	<input type="checkbox"/>	<input type="checkbox"/>
3							0	0	<input type="checkbox"/>	<input type="checkbox"/>

X: TTO LISTER: HK DATE: 05/05/2020 TIME: 12:00:00 AM LETTER LETTER REC'D GIS CODE

STREET/ROAD	TOPOGRAPHY	PU-UTILITIES-PR	NEIGHBORHOOD	INFLUENCE FACTORS	PROPERTY LOCATION
<input type="checkbox"/> PAVED <input type="checkbox"/> GRAVEL <input type="checkbox"/> DIRT <input type="checkbox"/> SIDEWALKS <input type="checkbox"/> CURBS	<input type="checkbox"/> LEVEL <input type="checkbox"/> HIGH <input type="checkbox"/> LOW <input type="checkbox"/> ROLLING <input type="checkbox"/> STANDARD	<input type="checkbox"/> WATER <input type="checkbox"/> SEWER <input type="checkbox"/> GAS <input type="checkbox"/> ELECTRIC <input type="checkbox"/> STANDARD	<input type="checkbox"/> IMPROVING <input type="checkbox"/> STATIC <input type="checkbox"/> DECLINING <input type="checkbox"/> OLD <input type="checkbox"/> STANDARD	<input type="checkbox"/> A. NO ROAD <input type="checkbox"/> B. TOPGRHY <input type="checkbox"/> C. Ex Front <input type="checkbox"/> D. QUANTITY <input type="checkbox"/> E. SZ/SHAPE	<input type="checkbox"/> F. RESTRICT <input type="checkbox"/> G. WOOD LT <input type="checkbox"/> H. VACANCY <input type="checkbox"/> I. WATER FRONT <input type="checkbox"/> J. OTHER/CDU
					1010 TERRACE AVE
COMMENT					

LAND COMPUTATIONS							
LAND TYPE	SIZE	M	RATE	C	INF	M	VALUE C
TOTAL						43,800	0

VALUATION SUMMARY

VALUE YEAR							
REASON FOR CHANGE							
APPRaised	<u>LAND</u>						
VALUE	<u>IMPR</u>						
	<u>TOTAL</u>						
ASSESSED	<u>LAND</u>						
VALUE	<u>IMPR</u>						
	<u>TOTAL</u>						

OCCUPANCY	EXTERIOR	FLOOR	AREA	CONST	VALUE
<input type="checkbox"/> SF <input type="checkbox"/> DU <input type="checkbox"/> TR	<input type="checkbox"/> WOOD				
<input type="checkbox"/> CONVERSION	<input type="checkbox"/> STUCCO				
BUILDING TYPE	<input type="checkbox"/> ALM/VYNL				
<input type="checkbox"/> MOBILE HOME	<input type="checkbox"/> CONC BLK				
<input type="checkbox"/> BI/TR LEVEL	<input type="checkbox"/> METAL				
<input type="checkbox"/> MOD/MAN	<input type="checkbox"/> BRICK				
<input type="checkbox"/> _____	<input type="checkbox"/> STONE				
ROOFING	ROOF TYPE				
<input type="checkbox"/> METAL	<input type="checkbox"/> GABLE				
<input type="checkbox"/> SLT/TLE	<input type="checkbox"/> HIP				
<input type="checkbox"/> SHINGLES	<input type="checkbox"/> GAMBREL				
<input type="checkbox"/> SHAKES	<input type="checkbox"/> MANSARD				
<input type="checkbox"/> COMPOSITE	<input type="checkbox"/> FLAT				
FLOORS	B	1	2	3	U
CONCRETE	<input type="checkbox"/>	<input type="checkbox"/>	<input type="checkbox"/>	<input type="checkbox"/>	<input type="checkbox"/>
WOOD	<input type="checkbox"/>	<input type="checkbox"/>	<input type="checkbox"/>	<input type="checkbox"/>	<input type="checkbox"/>
TILE/COMPO	<input type="checkbox"/>	<input type="checkbox"/>	<input type="checkbox"/>	<input type="checkbox"/>	<input type="checkbox"/>
CARPET	<input type="checkbox"/>	<input type="checkbox"/>	<input type="checkbox"/>	<input type="checkbox"/>	<input type="checkbox"/>
INT. FINISH	B	1	2	3	U
PLASTER/DW	<input type="checkbox"/>	<input type="checkbox"/>	<input type="checkbox"/>	<input type="checkbox"/>	<input type="checkbox"/>
PANELING	<input type="checkbox"/>	<input type="checkbox"/>	<input type="checkbox"/>	<input type="checkbox"/>	<input type="checkbox"/>
UNFINISHED	<input type="checkbox"/>	<input type="checkbox"/>	<input type="checkbox"/>	<input type="checkbox"/>	<input type="checkbox"/>
ACCOMMODATIONS					
# OF ROOMS					
BEDROOMS					
FIREPLACES					
HEAT & AC	B	1	2	3	U
NO HEAT	<input type="checkbox"/>	<input type="checkbox"/>	<input type="checkbox"/>	<input type="checkbox"/>	<input type="checkbox"/>
CTRL HEAT	<input type="checkbox"/>	<input type="checkbox"/>	<input type="checkbox"/>	<input type="checkbox"/>	<input type="checkbox"/>
HW/STEAM	<input type="checkbox"/>	<input type="checkbox"/>	<input type="checkbox"/>	<input type="checkbox"/>	<input type="checkbox"/>
ELECTRIC	<input type="checkbox"/>	<input type="checkbox"/>	<input type="checkbox"/>	<input type="checkbox"/>	<input type="checkbox"/>
HEAT PUMP	<input type="checkbox"/>	<input type="checkbox"/>	<input type="checkbox"/>	<input type="checkbox"/>	<input type="checkbox"/>
FLR/WALL	<input type="checkbox"/>	<input type="checkbox"/>	<input type="checkbox"/>	<input type="checkbox"/>	<input type="checkbox"/>
STVE/SPCE	<input type="checkbox"/>	<input type="checkbox"/>	<input type="checkbox"/>	<input type="checkbox"/>	<input type="checkbox"/>
GEOHERMAL	<input type="checkbox"/>	<input type="checkbox"/>	<input type="checkbox"/>	<input type="checkbox"/>	<input type="checkbox"/>
OUTSIDE	<input type="checkbox"/>	<input type="checkbox"/>	<input type="checkbox"/>	<input type="checkbox"/>	<input type="checkbox"/>
CTRL A/C	<input type="checkbox"/>	<input type="checkbox"/>	<input type="checkbox"/>	<input type="checkbox"/>	<input type="checkbox"/>
PLUMBING		BASE <input type="checkbox"/>			
X FULL BATH					
X HALF BATH					
X FIXTURES					
SUBTOTAL					0
MULTI-FAMILY #	0				0
BUILDING TYPE	000%				0
BSMT FINISH	0 S.F.				0
FIREPLACE #	0				0
HEATING	0 S.F.				0
AIR COND	0 S.F.				0
PLUMBING #	0				0
GARAGES & CARPORTS					0
EXTRA FEATURES					0
SUBTOTAL					0
GRADE FACTOR					%
UNADJUSTED VALUE					0
FACTOR					%

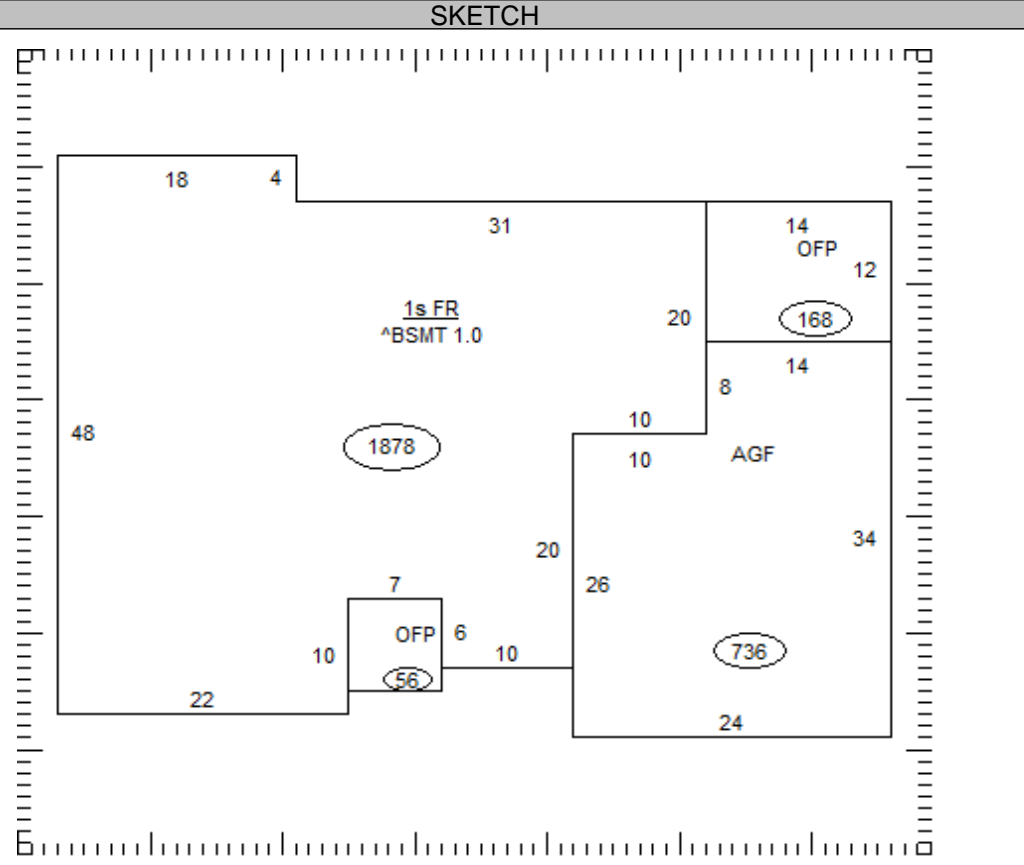

OCCUPANCY	ST.HT	SIZE	AREA	GRADE	PRICE	AGE	REMD	CND	UNADJ VAL	PHYS	PHYS VAL	FUNC	TRUE VAL
DWELLING		SK											
1													
2													
3													
4													
5													
6													
7													
8													
9													
10													
11													

05-225000.0000

TOTAL 0

COMMENTS