

BUTLER TWP-COLDWATER CORP / COLDWATER SD
08-28-354-004

Property Class: 510

Neighborhood
000509-TS70

Map: 14B6

Block:

Card: 24

Bk: Pg:

05-190100.0000

KESSEN KEITH K & SEITZ MICHELLE

KESSEN KEITH K & SEITZ MICHELLE

1015 GEORGE DR

COLDWATER, OH 45828

LEGAL INFORMATION

KAHLIG SUBD SECTION FIVE

LOT#: 1493

	OWNERSHIP	ADDRESS	CITY	STATE	ZIP	DATE	AMOUNT	DEED:CONV#	JS	VALID
1	KESSEN KEITH K & SEITZ	1015 GEORGE DR	COLDWATER	OH	45828	12/21/2016	315,000	WDC : 906	<input type="checkbox"/>	<input checked="" type="checkbox"/>
2	WENNING BENJAMIN J &	1015 GEORGE DR	COLDWATER	OH	45828	06/03/2003	181,000	: A : 0	<input type="checkbox"/>	<input checked="" type="checkbox"/>
3							0	0	<input type="checkbox"/>	<input type="checkbox"/>

X: TTO LISTER: NS DATE: 01/18/2005 TIME: 12:00:00 AM LETTER LETTER REC'D GIS CODE

STREET/ROAD TOPOGRAPHY PU-UTILITIES-PR NEIGHBORHOOD INFLUENCE FACTORS PROPERTY LOCATION

PAVED LEVEL WATER IMPROVING A. NO ROAD F. RESTRICT 1015 GEORGE DR, COLDWATER
 GRAVEL HIGH SEWER STATIC B. TOPGRHY G. WOOD LT
 DIRT LOW GAS DECLINING C. Ex Front H. VACANCY
 SIDEWALKS ROLLING ELECTRIC OLD D. QUANTITY I. WATER FRONT
 CURBS STANDARD STANDARD STANDARD E. SZ/SHAPE J. OTHER/CDU

PROPERTY LOCATION
1015 GEORGE DR, COLDWATER
COMMENT
TY2022:Net Gen=\$3,934.76, Other
Assessment=\$0.00
de09 per data mailer-add ofp-verified aerial
DE21 ADD BATH AND FIN BSMNT PER DATA
MAILER

LAND COMPUTATIONS

LAND TYPE	SIZE	M	RATE	C	INF	M	VALUE	C
F:Front	F120 D130	ST535	DP93	ADJ498			59,800	0
TOTAL							59,800	0

VALUATION SUMMARY

VALUE YEAR	2023	2021	2020	2017
REASON FOR CHANGE	RAPP	MISC	RAPP	RAPP
APPRAISED VALUE	59,800	46,100	46,100	41,900
	IMPR	346,700	259,900	241,500
	TOTAL	406,500	306,000	287,600
ASSESSED VALUE	20,930	16,140	16,140	14,670
	IMPR	121,350	90,970	84,530
	TOTAL	142,280	107,110	100,670

OCCUPANCY	EXTERIOR	FLOOR	AREA	CONST	VALUE
<input checked="" type="checkbox"/> SF <input type="checkbox"/> DU <input type="checkbox"/> TR	<input type="checkbox"/> WOOD	1	1908	BRK	243,790
<input type="checkbox"/> CONVERSION	<input type="checkbox"/> STUCCO				
BUILDING TYPE	<input type="checkbox"/> ALM/VYNL				
<input type="checkbox"/> MOBILE HOME	<input type="checkbox"/> CONC BLK				
<input type="checkbox"/> BI/TR LEVEL	<input type="checkbox"/> METAL				
<input type="checkbox"/> MOD/MAN	<input checked="" type="checkbox"/> BRICK				
<input type="checkbox"/>	<input type="checkbox"/> STONE				

ROOFING	ROOF TYPE
<input type="checkbox"/> METAL	<input checked="" type="checkbox"/> GABLE
<input type="checkbox"/> SLT/TLE	<input type="checkbox"/> HIP
<input checked="" type="checkbox"/> SHINGLES	<input type="checkbox"/> GAMBREL
<input type="checkbox"/> SHAKES	<input type="checkbox"/> MANSARD
<input type="checkbox"/> COMPOSITE	<input type="checkbox"/> FLAT

FLOORS	B	1	2	3	U
CONCRETE	<input checked="" type="checkbox"/>	<input type="checkbox"/>	<input type="checkbox"/>	<input type="checkbox"/>	<input type="checkbox"/>
WOOD	<input type="checkbox"/>	<input type="checkbox"/>	<input type="checkbox"/>	<input type="checkbox"/>	<input type="checkbox"/>
TILE/COMPO	<input type="checkbox"/>	<input checked="" type="checkbox"/>	<input type="checkbox"/>	<input type="checkbox"/>	<input type="checkbox"/>
CARPET	<input type="checkbox"/>	<input checked="" type="checkbox"/>	<input type="checkbox"/>	<input type="checkbox"/>	<input type="checkbox"/>
INT. FINISH	B	1	2	3	U
PLASTER/DW	<input type="checkbox"/>	<input checked="" type="checkbox"/>	<input type="checkbox"/>	<input type="checkbox"/>	<input type="checkbox"/>
PANELING	<input type="checkbox"/>	<input type="checkbox"/>	<input type="checkbox"/>	<input type="checkbox"/>	<input type="checkbox"/>
UNFINISHED	<input checked="" type="checkbox"/>	<input type="checkbox"/>	<input type="checkbox"/>	<input type="checkbox"/>	<input type="checkbox"/>
ACCOMMODATIONS					
# OF ROOMS	1	7			
BEDROOMS		3			
FIREPLACES					
HEAT & AC	B	1	2	3	U
NO HEAT	<input type="checkbox"/>	<input type="checkbox"/>	<input type="checkbox"/>	<input type="checkbox"/>	<input type="checkbox"/>
CTRL HEAT	<input type="checkbox"/>	<input checked="" type="checkbox"/>	<input type="checkbox"/>	<input type="checkbox"/>	<input type="checkbox"/>
HW/STEAM	<input type="checkbox"/>	<input type="checkbox"/>	<input type="checkbox"/>	<input type="checkbox"/>	<input type="checkbox"/>
ELECTRIC	<input type="checkbox"/>	<input type="checkbox"/>	<input type="checkbox"/>	<input type="checkbox"/>	<input type="checkbox"/>
HEAT PUMP	<input type="checkbox"/>	<input type="checkbox"/>	<input type="checkbox"/>	<input type="checkbox"/>	<input type="checkbox"/>
FLR/WALL	<input type="checkbox"/>	<input type="checkbox"/>	<input type="checkbox"/>	<input type="checkbox"/>	<input type="checkbox"/>
STVE/SPCE	<input type="checkbox"/>	<input type="checkbox"/>	<input type="checkbox"/>	<input type="checkbox"/>	<input type="checkbox"/>
GEO THERMAL	<input type="checkbox"/>	<input type="checkbox"/>	<input type="checkbox"/>	<input type="checkbox"/>	<input type="checkbox"/>
OUTSIDE	<input type="checkbox"/>	<input type="checkbox"/>	<input type="checkbox"/>	<input type="checkbox"/>	<input type="checkbox"/>
CTRL A/C	<input type="checkbox"/>	<input checked="" type="checkbox"/>	<input type="checkbox"/>	<input type="checkbox"/>	<input type="checkbox"/>
PLUMBING	BASE <input checked="" type="checkbox"/>				
X FULL BATH	1	1			
X HALF BATH		1			
X FIXTURES					

BSMT	1908		27,280
SUBTOTAL			271,070
MULTI-FAMILY #	0		0
BUILDING TYPE	100%		0
BSMT FINISH	954 S.F.		13,640
FIREPLACE #	0		0
HEATING	0 S.F.		0
AIR COND	1,908 S.F.		3,150
PLUMBING #	8		9,680
GARAGES & CARPORTS			30,000
EXTRA FEATURES			10,800
SUBTOTAL			338,340
GRADE FACTOR			115 %
UNADJUSTED VALUE			389,090
FACTOR			100 %

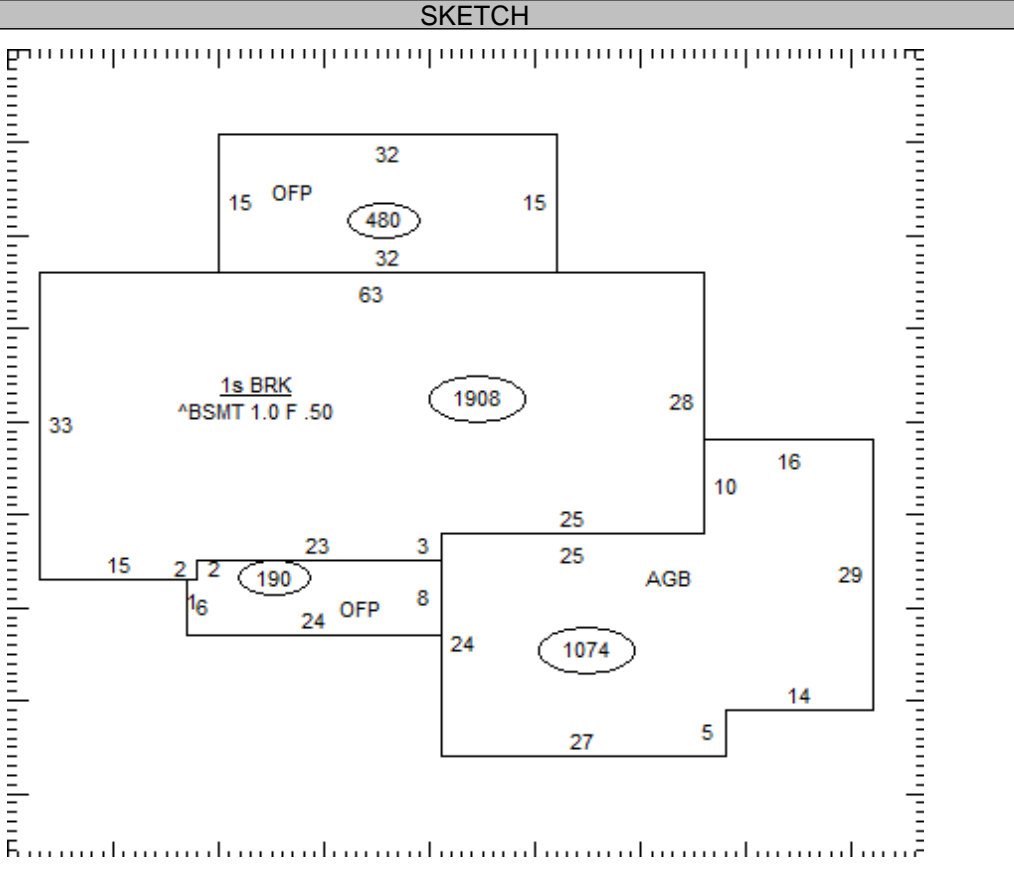

OCCUPANCY	ST.HT	SIZE	AREA	GRADE	PRICE	AGE	REMD	CND	UNADJ VAL	PHYS	PHYS VAL	FUNC	TRUE VAL
DWELLING	1	SK	1,908	B-		2002		A	389,090	19	315,160		346,700
1													
2													
3													
4													
5													
6													
7													
8													
9													
10													
11													

05-190100.0000	TOTAL	346,700
----------------	--------------	---------

COMMENTS

Dwelling has an Economic Factor of 110%