

05-166900.0000

**COLLINS JONATHAN J & ADDY M**  
COLLINS JONATHAN J & ADDY M  
905 CHELSEA DR  
COLDWATER, OH 45828

**LEGAL INFORMATION**  
KAHLIG SUBDIVISION  
SECTION 1  
LOT#: 1261

	OWNERSHIP	ADDRESS	CITY	STATE	ZIP	DATE	AMOUNT	DEED:CONV#	JS	VALID
1	COLLINS JONATHAN J & ADDY	905 CHELSEA DR	COLDWATER	OH	45828	06/22/2018	226,800	WDC : 445	<input type="checkbox"/>	<input checked="" type="checkbox"/>
2	KOESTERS GARY F & MARY	905 CHELSEA DR	COLDWATER	OH	45828	03/23/1989	94,000	: A : 0	<input type="checkbox"/>	<input checked="" type="checkbox"/>
3							0	0	<input type="checkbox"/>	<input type="checkbox"/>

X:  TTO LISTER: NS DATE: 01/20/2005 TIME: 12:00:00 AM  LETTER  LETTER REC'D GIS CODE

STREET/ROAD	TOPOGRAPHY	PU-UTILITIES-PR	NEIGHBORHOOD	INFLUENCE FACTORS		PROPERTY LOCATION
<input checked="" type="checkbox"/> PAVED <input type="checkbox"/> GRAVEL <input type="checkbox"/> DIRT <input checked="" type="checkbox"/> SIDEWALKS <input type="checkbox"/> CURBS	<input checked="" type="checkbox"/> LEVEL <input type="checkbox"/> HIGH <input type="checkbox"/> LOW <input type="checkbox"/> ROLLING <input type="checkbox"/> STANDARD	<input type="checkbox"/> WATER <input type="checkbox"/> SEWER <input type="checkbox"/> GAS <input type="checkbox"/> ELECTRIC <input checked="" type="checkbox"/> STANDARD	<input type="checkbox"/> IMPROVING <input type="checkbox"/> STATIC <input type="checkbox"/> DECLINING <input type="checkbox"/> OLD <input checked="" type="checkbox"/> STANDARD	<input type="checkbox"/> A. NO ROAD <input type="checkbox"/> B. TOPGRHY <input checked="" type="checkbox"/> C. Ex Front <input type="checkbox"/> D. QUANTITY <input type="checkbox"/> E. SZ/SHAPE	<input type="checkbox"/> F. RESTRICT <input type="checkbox"/> G. WOOD LT <input type="checkbox"/> H. VACANCY <input type="checkbox"/> I. WATER FRONT <input type="checkbox"/> J. OTHER/CDU	905 CHELSEA DR, COLDWATER

**COMMENT**  
TY2022:Net Gen=\$2,983.12, Other  
Assessment=\$0.00  
DE09 CORR PLMG PER DATA MAILER  
DE16 DESKTOP RVW CHG: CHG OFF TO OMP  
DE19 RMV OWN OCC; DIDN'T RET APP

LAND COMPUTATIONS

LAND TYPE	SIZE	M	RATE	C	INF	M	VALUE	C
F:Front	F134 D128	ST535	DP92	ADJ492	C:0.05		62,600	0
TOTAL							62,600	0

VALUATION SUMMARY

VALUE YEAR	2023	2020	2017					
REASON FOR CHANGE	RAPP	RAPP	RAPP					
APPRaised	LAND	62,600	48,300	43,900				
VALUE	IMPR	239,400	178,100	158,700				
	TOTAL	302,000	226,400	202,600				
ASSESSED	LAND	21,910	16,910	15,370				
VALUE	IMPR	83,790	62,340	55,550				
	TOTAL	105,700	79,250	70,920				

<b>OCCUPANCY</b>		<b>EXTERIOR</b>	
<input checked="" type="checkbox"/> SF	<input type="checkbox"/> DU	<input type="checkbox"/> TR	<input type="checkbox"/> WOOD
<input type="checkbox"/> CONVERSION	<input type="checkbox"/> STUCCO		
<b>BUILDING TYPE</b>		<input type="checkbox"/> ALM/VYNL	
<input type="checkbox"/> MOBILE HOME	<input type="checkbox"/> CONC BLK		
<input type="checkbox"/> BI/TR LEVEL	<input type="checkbox"/> METAL		
<input type="checkbox"/> MOD/MAN	<input checked="" type="checkbox"/> BRICK		
<input type="checkbox"/>	<input type="checkbox"/> STONE		

<b>ROOFING</b>		<b>ROOF TYPE</b>	
<input type="checkbox"/> METAL	<input checked="" type="checkbox"/> GABLE		
<input type="checkbox"/> SLT/TLE	<input type="checkbox"/> HIP		
<input checked="" type="checkbox"/> SHINGLES	<input type="checkbox"/> GAMBREL		
<input type="checkbox"/> SHAKES	<input type="checkbox"/> MANSARD		
<input type="checkbox"/> COMPOSITE	<input type="checkbox"/> FLAT		

<b>FLOORS</b>		B	1	2	3	U
CONCRETE	<input type="checkbox"/>	<input type="checkbox"/>	<input type="checkbox"/>	<input type="checkbox"/>	<input type="checkbox"/>	<input type="checkbox"/>
WOOD	<input type="checkbox"/>	<input type="checkbox"/>	<input type="checkbox"/>	<input type="checkbox"/>	<input type="checkbox"/>	<input type="checkbox"/>
TILE/COMPO	<input type="checkbox"/>	<input checked="" type="checkbox"/>	<input type="checkbox"/>	<input type="checkbox"/>	<input type="checkbox"/>	<input type="checkbox"/>
CARPET	<input type="checkbox"/>	<input checked="" type="checkbox"/>	<input type="checkbox"/>	<input type="checkbox"/>	<input type="checkbox"/>	<input type="checkbox"/>

<b>INT. FINISH</b>		B	1	2	3	U
PLASTER/DW	<input type="checkbox"/>	<input checked="" type="checkbox"/>	<input type="checkbox"/>	<input type="checkbox"/>	<input type="checkbox"/>	<input type="checkbox"/>
PANELING	<input type="checkbox"/>	<input type="checkbox"/>	<input type="checkbox"/>	<input type="checkbox"/>	<input type="checkbox"/>	<input type="checkbox"/>
UNFINISHED	<input type="checkbox"/>	<input type="checkbox"/>	<input type="checkbox"/>	<input type="checkbox"/>	<input type="checkbox"/>	<input type="checkbox"/>

<b>ACCOMMODATIONS</b>						
# OF ROOMS	5	6				
BEDROOMS	1	3				
FIREPLACES	1					
<b>HEAT &amp; AC</b>		B	1	2	3	U

NO HEAT	<input type="checkbox"/>	<input type="checkbox"/>	<input type="checkbox"/>	<input type="checkbox"/>	<input type="checkbox"/>
CTRL HEAT	<input checked="" type="checkbox"/>	<input checked="" type="checkbox"/>	<input type="checkbox"/>	<input type="checkbox"/>	<input type="checkbox"/>
HW/STEAM	<input type="checkbox"/>	<input type="checkbox"/>	<input type="checkbox"/>	<input type="checkbox"/>	<input type="checkbox"/>
ELECTRIC	<input type="checkbox"/>	<input type="checkbox"/>	<input type="checkbox"/>	<input type="checkbox"/>	<input type="checkbox"/>
HEAT PUMP	<input type="checkbox"/>	<input type="checkbox"/>	<input type="checkbox"/>	<input type="checkbox"/>	<input type="checkbox"/>
FLR/WALL	<input type="checkbox"/>	<input type="checkbox"/>	<input type="checkbox"/>	<input type="checkbox"/>	<input type="checkbox"/>
STVE/SPCE	<input type="checkbox"/>	<input type="checkbox"/>	<input type="checkbox"/>	<input type="checkbox"/>	<input type="checkbox"/>
GEO THERMAL	<input type="checkbox"/>	<input type="checkbox"/>	<input type="checkbox"/>	<input type="checkbox"/>	<input type="checkbox"/>
OUTSIDE	<input type="checkbox"/>	<input type="checkbox"/>	<input type="checkbox"/>	<input type="checkbox"/>	<input type="checkbox"/>
CTRL A/C	<input type="checkbox"/>	<input checked="" type="checkbox"/>	<input type="checkbox"/>	<input type="checkbox"/>	<input type="checkbox"/>

<b>PLUMBING</b>		<b>BASE</b>			
X FULL BATH		2			
X HALF BATH					
X FIXTURES					

FLOOR	AREA	CONST	VALUE
1	1452	BRK	211,050
BSMT	1452		20,760
<b>SUBTOTAL</b>			231,810
MULTI-FAMILY #	0		0
BUILDING TYPE	100%		0
BSMT FINISH	1,089 S.F.		15,570
FIREPLACE #	1		4,400
HEATING	0 S.F.		0
AIR COND	1,452 S.F.		2,400
PLUMBING #	6		7,260
GARAGES & CARPORTS			14,800
EXTRA FEATURES			3,900
<b>SUBTOTAL</b>			280,140
GRADE FACTOR			105 %
<b>UNADJUSTED VALUE</b>			294,150
FACTOR			100 %

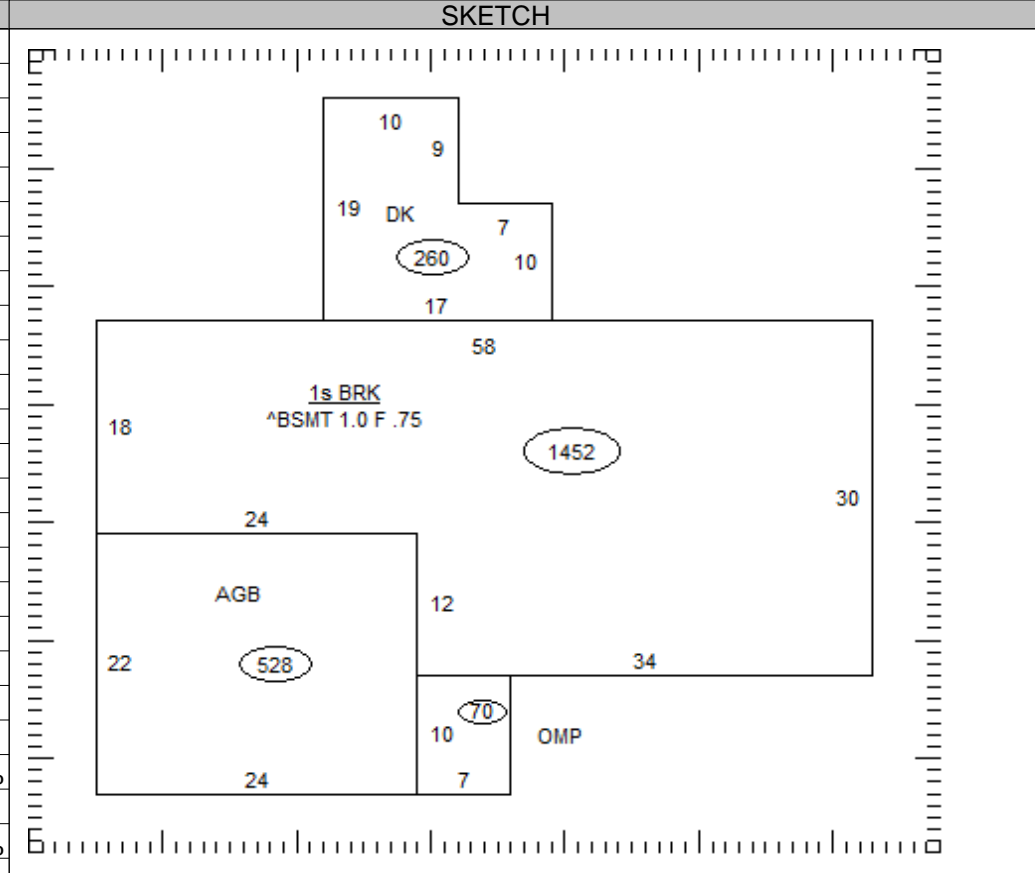

OCCUPANCY	ST.HT	SIZE	AREA	GRADE	PRICE	AGE	REMD	CND	UNADJ VAL	PHYS	PHYS VAL	FUNC	TRUE VAL
DWELLING	1	SK	1,452	C+		1989		A	294,150	26	217,670		239,400
1													
2													
3													
4													
5													
6													
7													
8													
9													
10													
11													

05-166900.0000 TOTAL 239,400

**COMMENTS**

Dwelling has an Economic Factor of 110%