

BUTLER TWP-COLDWATER CORP / COLDWATER SD  
08-28-306-009

Property Class: 510  
Neighborhood  
000509-TS70  
Map: 14B7  
Block:  
Card: 09  
Bk: Pg:

05-163200.0000

**LEGAL INFORMATION**  
OAKWOOD SECOND ADD

LOT#: 1224

**SWARTZEL DEVIN R**  
SWARTZEL DEVIN R  
1009 NORTHFIELD DR  
COLDWATER, OH 45828

	OWNERSHIP	ADDRESS	CITY	STATE	ZIP	DATE	AMOUNT	DEED:CONV#	JS	VALID
1	SWARTZEL DEVIN R	1009 NORTHFIELD DR	COLDWATER	OH	45828	05/22/2023	0	QCE : X : 0	<input type="checkbox"/>	<input type="checkbox"/>
2	SWARTZEL DEVIN R SWARTZEL JEFFREY K LIFE ESTATE	906 MARY CHARLES LN	COLDWATER	OH	45828	01/11/2010	0	QCE : X : 0	<input type="checkbox"/>	<input type="checkbox"/>
3	SWARTZEL RICHARD JK & SWARTZEL JEFFREY K LIFE ESTATE	906 MARY CHARLES LN	COLDWATER	OH	45828	12/21/2009	0	QCE : x : 0	<input type="checkbox"/>	<input type="checkbox"/>

X:  TTO LISTER: NS DATE: 01/19/2005 TIME: 12:00:00 AM  LETTER  LETTER REC'D GIS CODE

STREET/ROAD	TOPOGRAPHY	PU-UTILITIES-PR	NEIGHBORHOOD	INFLUENCE FACTORS				PROPERTY LOCATION
<input checked="" type="checkbox"/> PAVED	<input checked="" type="checkbox"/> LEVEL	<input type="checkbox"/> WATER <input type="checkbox"/>	<input type="checkbox"/> IMPROVING	<input type="checkbox"/> A. NO ROAD	<input type="checkbox"/> F. RESTRICT	906 MARY CHARLES LN, COLDWATER		
<input type="checkbox"/> GRAVEL	<input type="checkbox"/> HIGH	<input type="checkbox"/> SEWER <input type="checkbox"/>	<input type="checkbox"/> STATIC	<input type="checkbox"/> B. TOPGRHY	<input type="checkbox"/> G. WOOD LT	COMMENT		
<input type="checkbox"/> DIRT	<input type="checkbox"/> LOW	<input type="checkbox"/> GAS <input type="checkbox"/>	<input type="checkbox"/> DECLINING	<input type="checkbox"/> C. Ex Front	<input type="checkbox"/> H. VACANCY	TY2022:Net Gen=\$2,841.88, Other		
<input checked="" type="checkbox"/> SIDEWALKS	<input type="checkbox"/> ROLLING	<input type="checkbox"/> ELECTRIC <input type="checkbox"/>	<input type="checkbox"/> OLD	<input type="checkbox"/> D. QUANTITY	<input type="checkbox"/> I. WATER FRONT	Assessment=\$0.00		
<input type="checkbox"/> CURBS	<input type="checkbox"/> STANDARD	<input checked="" type="checkbox"/> STANDARD	<input checked="" type="checkbox"/> STANDARD	<input type="checkbox"/> E. SZ/SHAPE	<input type="checkbox"/> J. OTHER/CDU	DE16 DESKTOP RVW CHG: ADD BW		
LAND COMPUTATIONS								
LAND TYPE	SIZE	M	RATE	C	INF	M	VALUE	C
F:Front	F100 D111	ST535	DP85	ADJ455		45,500	0	
TOTAL						45,500	0	

TY2022:Net Gen=\$2,841.88, Other  
Assessment=\$0.00  
DE16 DESKTOP RVW CHG: ADD BW  
DE15 MINOR SKETCH COR, ADD WD FP, COR  
PLMG PER DAT MAILER  
DE11 COR OFF  
DE09 PER DATA MAILER CORRECTED FIN  
BASEMENT & PLMG

**VALUATION SUMMARY**

VALUE YEAR	2023	2020	2017				
REASON FOR CHANGE	RAPP	RAPP	RAPP				
APPRAISED	LAND	45,500	35,100	31,900			
VALUE	IMPR	249,600	185,900	161,300			
	TOTAL	295,100	221,000	193,200			
ASSESSED	LAND	15,930	12,290	11,170			
VALUE	IMPR	87,360	65,070	56,460			
	TOTAL	103,290	77,360	67,630			

**OCCUPANCY**  
 SF  DU  TR  
 CONVERSION  
**BUILDING TYPE**  
 MOBILE HOME  
 BI/TR LEVEL  
 MOD/MAN

**EXTERIOR**  
 WOOD  
 STUCCO  
 ALM/VYNL  
 CONC BLK  
 METAL  
 BRICK  
 STONE

**ROOFING**  
 METAL  
 SLT/TLE  
 SHINGLES  
 SHAKES  
 COMPOSITE

**ROOF TYPE**  
 GABLE  
 HIP  
 GAMBREL  
 MANSARD  
 FLAT

**FLOORS** B 1 2 3 U  
 CONCRETE       
 WOOD       
 TILE/COMPO       
 CARPET

**INT. FINISH** B 1 2 3 U  
 PLASTER/DW       
 PANELING       
 UNFINISHED

**ACCOMMODATIONS**  
 # OF ROOMS   4  2   
 BEDROOMS   1  2   
 FIREPLACES   1

**HEAT & AC** B 1 2 3 U  
 NO HEAT       
 CTRL HEAT       
 HW/STEAM       
 ELECTRIC       
 HEAT PUMP       
 FLR/WALL       
 STVE/SPCE       
 GEOTHERMAL       
 OUTSIDE       
 CTRL A/C

**PLUMBING** BASE   
 X FULL BATH    1   
 X HALF BATH 1     
 X FIXTURES 1 1

FLOOR	AREA	CONST	VALUE
1	1344	FR	192,140
2ND	526	FR	36,100
BSMT	1074		15,360
<b>SUBTOTAL</b>			243,600
MULTI-FAMILY #	0		0
BUILDING TYPE	100%		0
BSMT FINISH	894 S.F.		12,780
FIREPLACE #	1		4,400
HEATING	0 S.F.		0
AIR COND	2,764 S.F.		4,570
PLUMBING #	7		8,470
GARAGES & CARPORTS			12,000
EXTRA FEATURES			14,300
<b>SUBTOTAL</b>			300,120
GRADE FACTOR			105 %
<b>UNADJUSTED VALUE</b>			315,130
FACTOR			100 %

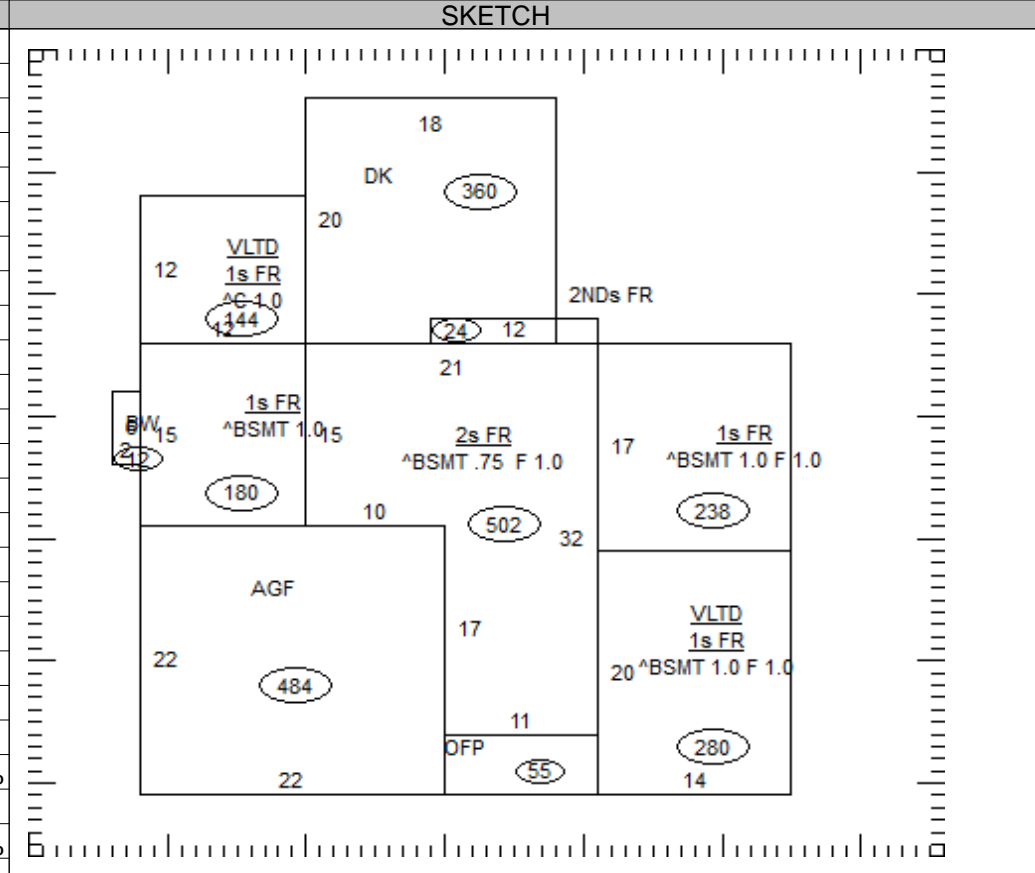

OCCUPANCY	ST.HT	SIZE	AREA	GRADE	PRICE	AGE	REMD	CND	UNADJ VAL	PHYS	PHYS VAL	FUNC	TRUE VAL
DWELLING	2	SK	1,870	C+		1985		A	315,130	28	226,890		249,600
1													
2													
3													
4													
5													
6													
7													
8													
9													
10													
11													

05-163200.0000 TOTAL 249,600

**COMMENTS**

Dwelling has an Economic Factor of 110%

BUTLER TWP-COLDWATER CORP / COLDWATER SD  
08-28-306-009

Property Class: 510

Neighborhood  
000509-TS70

Map: 14B7

Block:

Card: 09

Bk: Pg:

05-163200.0000

**SWARTZEL DEVIN R**  
SWARTZEL DEVIN R  
1009 NORTHFIELD DR  
COLDWATER, OH 45828

**LEGAL INFORMATION**  
OAKWOOD SECOND ADD

LOT#: 1224

	OWNERSHIP	ADDRESS	CITY	STATE	ZIP	DATE	AMOUNT	DEED:CONV#	JS	VALID
1	SWARTZEL JEFFREY K	906 MARY CHARLES LN	COLDWATER	OH	45828	09/17/1998	0	: X : 0	<input type="checkbox"/>	<input type="checkbox"/>
2							0	0	<input type="checkbox"/>	<input type="checkbox"/>
3							0	0	<input type="checkbox"/>	<input type="checkbox"/>

X:  TTO LISTER: NS DATE: 01/19/2005 TIME: 12:00:00 AM  LETTER  LETTER REC'D GIS CODE

STREET/ROAD	TOPOGRAPHY	PU-UTILITIES-PR	NEIGHBORHOOD	INFLUENCE FACTORS	PROPERTY LOCATION	
<input checked="" type="checkbox"/> PAVED <input type="checkbox"/> GRAVEL <input type="checkbox"/> DIRT <input checked="" type="checkbox"/> SIDEWALKS <input type="checkbox"/> CURBS	<input checked="" type="checkbox"/> LEVEL <input type="checkbox"/> HIGH <input type="checkbox"/> LOW <input type="checkbox"/> ROLLING <input type="checkbox"/> STANDARD	<input type="checkbox"/> WATER <input type="checkbox"/> SEWER <input type="checkbox"/> GAS <input type="checkbox"/> ELECTRIC <input checked="" type="checkbox"/> STANDARD	<input type="checkbox"/> IMPROVING <input type="checkbox"/> STATIC <input type="checkbox"/> DECLINING <input type="checkbox"/> OLD <input checked="" type="checkbox"/> STANDARD	<input type="checkbox"/> A. NO ROAD <input type="checkbox"/> B. TOPGRHY <input type="checkbox"/> C. Ex Front <input type="checkbox"/> D. QUANTITY <input type="checkbox"/> E. SZ/SHAPE	<input type="checkbox"/> F. RESTRICT <input type="checkbox"/> G. WOOD LT <input type="checkbox"/> H. VACANCY <input type="checkbox"/> I. WATER FRONT <input type="checkbox"/> J. OTHER/CDU	906 MARY CHARLES LN, COLDWATER COMMENT

LAND COMPUTATIONS							
LAND TYPE	SIZE	M	RATE	C	INF	M	VALUE C
TOTAL						45,500	0

**VALUATION SUMMARY**

VALUE YEAR	REASON FOR CHANGE	APPRaised	IMPR	TOTAL	ASSESSED	IMPR	TOTAL

OCCUPANCY	EXTERIOR	FLOOR	AREA	CONST	VALUE
<input type="checkbox"/> SF <input type="checkbox"/> DU <input type="checkbox"/> TR	<input type="checkbox"/> WOOD				
<input type="checkbox"/> CONVERSION	<input type="checkbox"/> STUCCO				
<b>BUILDING TYPE</b>	<input type="checkbox"/> ALM/VYNL				
<input type="checkbox"/> MOBILE HOME	<input type="checkbox"/> CONC BLK				
<input type="checkbox"/> BI/TR LEVEL	<input type="checkbox"/> METAL				
<input type="checkbox"/> MOD/MAN	<input type="checkbox"/> BRICK				
<input type="checkbox"/>	<input type="checkbox"/> STONE				
ROOFING	ROOF TYPE				
<input type="checkbox"/> METAL	<input type="checkbox"/> GABLE				
<input type="checkbox"/> SLT/TLE	<input type="checkbox"/> HIP				
<input type="checkbox"/> SHINGLES	<input type="checkbox"/> GAMBREL				
<input type="checkbox"/> SHAKES	<input type="checkbox"/> MANSARD				
<input type="checkbox"/> COMPOSITE	<input type="checkbox"/> FLAT				

<b>SUBTOTAL</b>		0
MULTI-FAMILY #	0	0
BUILDING TYPE	000%	0
BSMT FINISH	0 S.F.	0
FIREPLACE #	0	0
HEATING	0 S.F.	0
AIR COND	0 S.F.	0
PLUMBING #	0	0
GARAGES & CARPORTS		0
EXTRA FEATURES		0
<b>SUBTOTAL</b>		0
GRADE FACTOR		%
<b>UNADJUSTED VALUE</b>		0
<b>FACTOR</b>		%

FLOORS	B	1	2	3	U
CONCRETE	<input type="checkbox"/>	<input type="checkbox"/>	<input type="checkbox"/>	<input type="checkbox"/>	<input type="checkbox"/>
WOOD	<input type="checkbox"/>	<input type="checkbox"/>	<input type="checkbox"/>	<input type="checkbox"/>	<input type="checkbox"/>
TILE/COMPO	<input type="checkbox"/>	<input type="checkbox"/>	<input type="checkbox"/>	<input type="checkbox"/>	<input type="checkbox"/>
CARPET	<input type="checkbox"/>	<input type="checkbox"/>	<input type="checkbox"/>	<input type="checkbox"/>	<input type="checkbox"/>
INT. FINISH	B	1	2	3	U
PLASTER/DW	<input type="checkbox"/>	<input type="checkbox"/>	<input type="checkbox"/>	<input type="checkbox"/>	<input type="checkbox"/>
PANELING	<input type="checkbox"/>	<input type="checkbox"/>	<input type="checkbox"/>	<input type="checkbox"/>	<input type="checkbox"/>
UNFINISHED	<input type="checkbox"/>	<input type="checkbox"/>	<input type="checkbox"/>	<input type="checkbox"/>	<input type="checkbox"/>
ACCOMMODATIONS					
# OF ROOMS					
BEDROOMS					
FIREPLACES					
HEAT & AC	B	1	2	3	U
NO HEAT	<input type="checkbox"/>	<input type="checkbox"/>	<input type="checkbox"/>	<input type="checkbox"/>	<input type="checkbox"/>
CTRL HEAT	<input type="checkbox"/>	<input type="checkbox"/>	<input type="checkbox"/>	<input type="checkbox"/>	<input type="checkbox"/>
HW/STEAM	<input type="checkbox"/>	<input type="checkbox"/>	<input type="checkbox"/>	<input type="checkbox"/>	<input type="checkbox"/>
ELECTRIC	<input type="checkbox"/>	<input type="checkbox"/>	<input type="checkbox"/>	<input type="checkbox"/>	<input type="checkbox"/>
HEAT PUMP	<input type="checkbox"/>	<input type="checkbox"/>	<input type="checkbox"/>	<input type="checkbox"/>	<input type="checkbox"/>
FLR/WALL	<input type="checkbox"/>	<input type="checkbox"/>	<input type="checkbox"/>	<input type="checkbox"/>	<input type="checkbox"/>
STVE/SPCE	<input type="checkbox"/>	<input type="checkbox"/>	<input type="checkbox"/>	<input type="checkbox"/>	<input type="checkbox"/>
GEO THERMAL	<input type="checkbox"/>	<input type="checkbox"/>	<input type="checkbox"/>	<input type="checkbox"/>	<input type="checkbox"/>
OUTSIDE	<input type="checkbox"/>	<input type="checkbox"/>	<input type="checkbox"/>	<input type="checkbox"/>	<input type="checkbox"/>
CTRL A/C	<input type="checkbox"/>	<input type="checkbox"/>	<input type="checkbox"/>	<input type="checkbox"/>	<input type="checkbox"/>
PLUMBING		BASE <input type="checkbox"/>			
X FULL BATH					
X HALF BATH					
X FIXTURES					

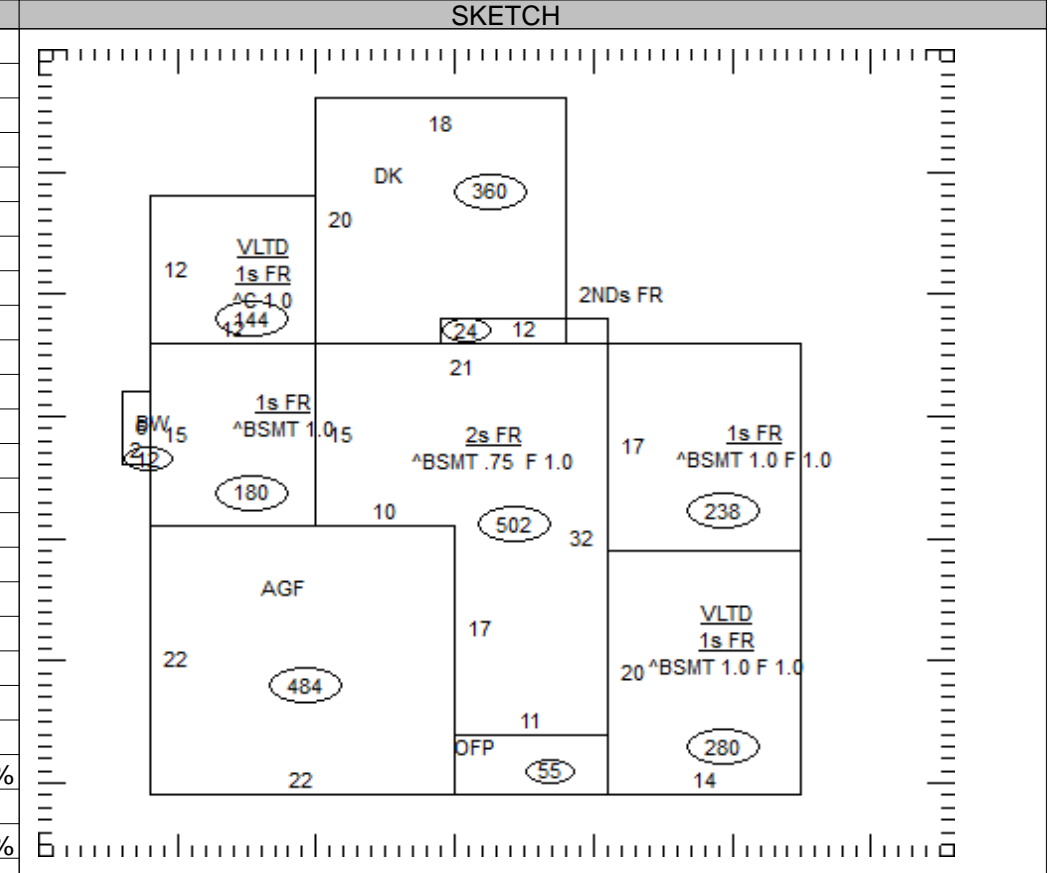

OCCUPANCY	ST.HT	SIZE	AREA	GRADE	PRICE	AGE	REMD	CND	UNADJ VAL	PHYS	PHYS VAL	FUNC	TRUE VAL
DWELLING		SK											
1													
2													
3													
4													
5													
6													
7													
8													
9													
10													
11													

05-163200.0000

TOTAL 0

COMMENTS