

BUTLER TWP-COLDWATER CORP / COLDWATER SD  
08-27-327-001

Property Class: 510

Neighborhood  
000501-TM40

Map: 14A5

Block:

Card: 74

Bk: Pg:

05-161200.0000

**LEGAL INFORMATION**  
RESTFUL ACRES TENTH ADD

LOT#: 1204

**BRUNS PAMELA J**  
BRUNS PAMELA J  
724 LILAC DR  
COLDWATER, OH 45828

	OWNERSHIP	ADDRESS	CITY	STATE	ZIP	DATE	AMOUNT	DEED:CONV#	JS	VALID
1	BRUNS PAMELA J	724 LILAC DR	COLDWATER	OH	45828	08/02/2021	144,000	WDC : 629	<input type="checkbox"/>	<input checked="" type="checkbox"/>
2	MESCHER EMILY M	724 LILAC ST	COLDWATER	OH	45828	12/28/2005	79,500	WDC : A : 1077	<input type="checkbox"/>	<input checked="" type="checkbox"/>
3	FISHER THOMAS D & RENEE E	724 LILAC ST	COLDWATER	OH	45828	05/31/2000	72,000	: A : 0	<input type="checkbox"/>	<input checked="" type="checkbox"/>

X:  TTO LISTER: NS DATE: 02/24/2005 TIME: 12:00:00 AM  LETTER  LETTER REC'D GIS CODE

STREET/ROAD	TOPOGRAPHY	PU-UTILITIES-PR	NEIGHBORHOOD	INFLUENCE FACTORS	PROPERTY LOCATION	
<input checked="" type="checkbox"/> PAVED <input type="checkbox"/> GRAVEL <input type="checkbox"/> DIRT <input checked="" type="checkbox"/> SIDEWALKS <input type="checkbox"/> CURBS	<input checked="" type="checkbox"/> LEVEL <input type="checkbox"/> HIGH <input type="checkbox"/> LOW <input type="checkbox"/> ROLLING <input type="checkbox"/> STANDARD	<input type="checkbox"/> WATER <input type="checkbox"/> SEWER <input type="checkbox"/> GAS <input type="checkbox"/> ELECTRIC <input checked="" type="checkbox"/> STANDARD	<input checked="" type="checkbox"/> IMPROVING <input type="checkbox"/> STATIC <input type="checkbox"/> DECLINING <input type="checkbox"/> OLD <input type="checkbox"/> STANDARD	<input type="checkbox"/> A. NO ROAD <input type="checkbox"/> B. TOPGRHY <input type="checkbox"/> C. Ex Front <input type="checkbox"/> D. QUANTITY <input type="checkbox"/> E. SZ/SHAPE	<input type="checkbox"/> F. RESTRICT <input type="checkbox"/> G. WOOD LT <input type="checkbox"/> H. VACANCY <input type="checkbox"/> I. WATER FRONT <input type="checkbox"/> J. OTHER/CDU	724 LILAC DR, COLDWATER <b>COMMENT</b> TY2022:Net Gen=\$1,701.22, Other Assessment=\$0.00

LAND COMPUTATIONS

LAND TYPE	SIZE	M	RATE	C	INF	M	VALUE	C
F:Front	F100 D120	ST350	DP89	ADJ312			31,200	0
TOTAL							31,200	0

VALUATION SUMMARY

VALUE YEAR	2023	2020	2017					
REASON FOR CHANGE	RAPP	RAPP	RAPP					
APPRAISED VALUE	<u>LAND</u> 31,200	20,400	15,100					
	<u>IMPR</u> 143,600	111,900	94,100					
	<u>TOTAL</u> 174,800	132,300	109,200					
ASSESSED VALUE	<u>LAND</u> 10,920	7,140	5,290					
	<u>IMPR</u> 50,260	39,170	32,940					
	<u>TOTAL</u> 61,180	46,310	38,230					

**OCCUPANCY**  SF  DU  TR  
 CONVERSION  
**BUILDING TYPE**  
 MOBILE HOME  
 BI/TR LEVEL  
 MOD/MAN

FLOOR	AREA	CONST	VALUE
1	1092	FR	170,330

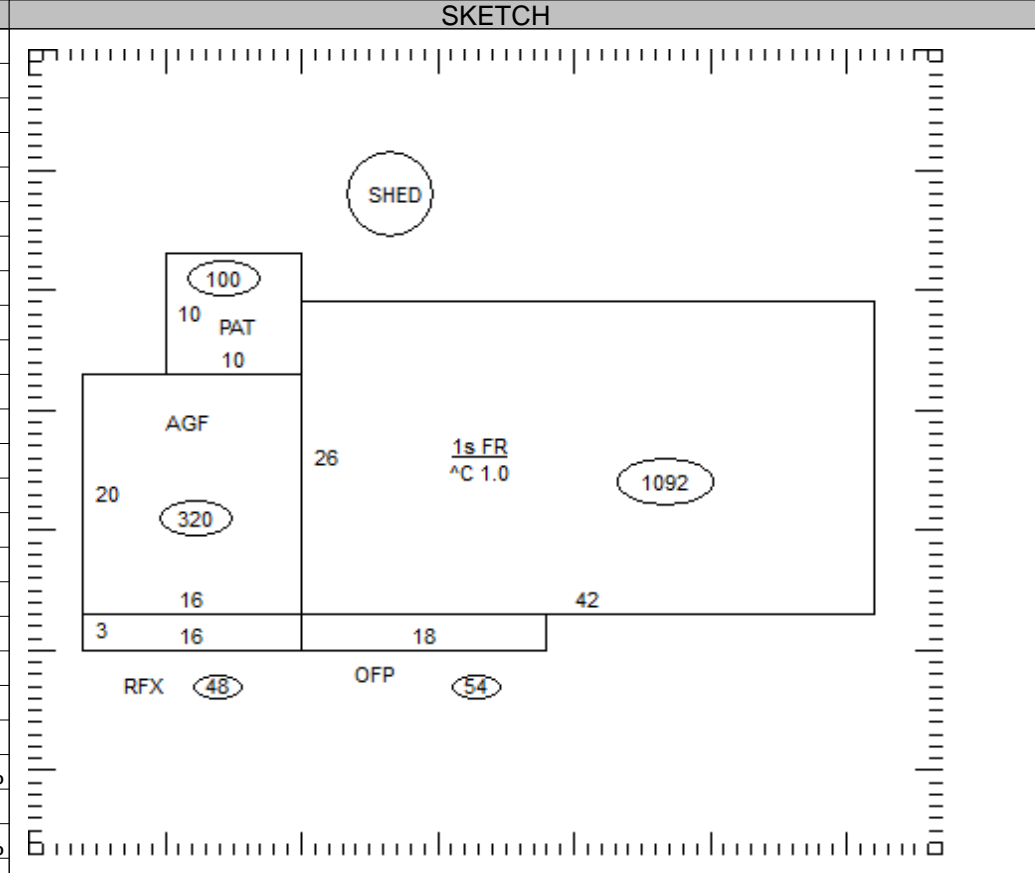

**ROOFING**  
 METAL  
 SLT/TLE  
 SHINGLES  
 SHAKES  
 COMPOSITE

**ROOF TYPE**  
 GABLE  
 HIP  
 GAMBREL  
 MANSARD  
 FLAT

SUBTOTAL			170,330
MULTI-FAMILY #	0		0
BUILDING TYPE	100%		0
BSMT FINISH	0 S.F.		0
FIREPLACE #	0		0
HEATING	0 S.F.		0
AIR COND	0 S.F.		0
PLUMBING #	0		0
GARAGES & CARPORTS			7,900
EXTRA FEATURES			1,700
SUBTOTAL			179,930
GRADE FACTOR			100 %
UNADJUSTED VALUE			179,930
FACTOR			100 %

**FLOORS** B 1 2 3 U  
 CONCRETE       
 WOOD       
 TILE/COMPO       
 CARPET

INT. FINISH	B	1	2	3	U
PLASTER/DW	<input type="checkbox"/>	<input checked="" type="checkbox"/>	<input type="checkbox"/>	<input type="checkbox"/>	<input type="checkbox"/>
PANELING	<input type="checkbox"/>	<input type="checkbox"/>	<input type="checkbox"/>	<input type="checkbox"/>	<input type="checkbox"/>
UNFINISHED	<input type="checkbox"/>	<input type="checkbox"/>	<input type="checkbox"/>	<input type="checkbox"/>	<input type="checkbox"/>

**ACCOMMODATIONS**  
 # OF ROOMS 6  
 BEDROOMS 3  
 FIREPLACES  
 HEAT & AC B 1 2 3 U

ACCOMMODATIONS					
# OF ROOMS		6			
BEDROOMS		3			
FIREPLACES					
HEAT & AC	B	1	2	3	U

NO HEAT       
 CTRL HEAT       
 HW/STEAM       
 ELECTRIC       
 HEAT PUMP       
 FLR/WALL       
 STVE/SPCE       
 GEOTHERMAL       
 OUTSIDE       
 CTRL A/C       
 PLUMBING BASE

X FULL BATH  
 X HALF BATH  
 X FIXTURES

OCCUPANCY	ST.HT	SIZE	AREA	GRADE	PRICE	AGE	REMD	CND	UNADJ VAL	PHYS	PHYS VAL	FUNC	TRUE VAL
DWELLING	1	SK	1,092	C		1994		A	179,930	24	136,750		143,600
1 Shed		10x10	100	C		2000		A		37			0
2													
3													
4													
5													
6													
7													
8													
9													
10													
11													

05-161200.0000

TOTAL 143,600

**COMMENTS**  
 BRICK TRIM 36 X 8  
 Dwelling has an Economic Factor of 105%