



05-151800.0000

JRNR SOLUTIONS LLC

JRNR SOLUTIONS LLC

618 RAY DR

COLDWATER, OH 45828

BUTLER TWP-COLDWATER CORP / COLDWATER SD

08-28-377-003

**LEGAL INFORMATION**

SELHORST THIRTEENTH ADD

LOT#: 1111

Page 1 of 2  
 Property Class: 510  
 Neighborhood  
 000508-TS50  
 Map: 14B5  
 Block:  
 Card: 11  
 Bk: Pg:

	OWNERSHIP	ADDRESS	CITY	STATE	ZIP	DATE	AMOUNT	DEED:CONV#	JS	VALID
1	JRNR SOLUTIONS LLC	618 RAY DR	COLDWATER	OH	45828	02/15/2023	290,000	WDC : 71	<input type="checkbox"/>	<input checked="" type="checkbox"/>
2	BRUNS GARY L	313 N WOODVIEW DR	COLDWATER	OH	45828	01/08/2021	0	QCE : X : 0	<input type="checkbox"/>	<input type="checkbox"/>
3	BRUNS GARY L	313 WOODVIEW DR	COLDWATER	OH	45828	10/03/2014	159,900	WDC : 661	<input type="checkbox"/>	<input checked="" type="checkbox"/>

X:  TTO LISTER: NS DATE: 01/14/2005 TIME: 12:00:00 AM  LETTER  LETTER REC'D GIS CODE

STREET/ROAD		TOPOGRAPHY	PU-UTILITIES-PR	NEIGHBORHOOD	INFLUENCE FACTORS				PROPERTY LOCATION	
<input checked="" type="checkbox"/> PAVED	<input checked="" type="checkbox"/> LEVEL	<input type="checkbox"/> WATER	<input type="checkbox"/> IMPROVING	<input type="checkbox"/> A. NO ROAD	<input type="checkbox"/> F. RESTRICT	313 WOODVIEW DR, COLDWATER				
<input type="checkbox"/> GRAVEL	<input type="checkbox"/> HIGH	<input type="checkbox"/> SEWER	<input type="checkbox"/> STATIC	<input type="checkbox"/> B. TOPGRHY	<input type="checkbox"/> G. WOOD LT	COMMENT TY2022:Net Gen=\$2,466.32, Other Assessment=\$0.00 DE16 DESKTOP RVW CHG: COR WDDK SIZE DE22 RMV OWN OCC - DID NOT RETURN APP				
<input type="checkbox"/> DIRT	<input type="checkbox"/> LOW	<input type="checkbox"/> GAS	<input type="checkbox"/> DECLINING	<input type="checkbox"/> C. Ex Front	<input type="checkbox"/> H. VACANCY					
<input checked="" type="checkbox"/> SIDEWALKS	<input type="checkbox"/> ROLLING	<input type="checkbox"/> ELECTRIC	<input type="checkbox"/> OLD	<input type="checkbox"/> D. QUANTITY	<input type="checkbox"/> I. WATER FRONT					
<input type="checkbox"/> CURBS	<input type="checkbox"/> STANDARD	<input checked="" type="checkbox"/> STANDARD	<input type="checkbox"/> STANDARD	<input type="checkbox"/> E. SZ/SHAPE	<input type="checkbox"/> J. OTHER/CDU					
LAND COMPUTATIONS										
LAND TYPE	SIZE	M	RATE	C	INF	M	VALUE	C		
F:Front	F85 D115	ST410	DP87	ADJ357		30,300	0			
TOTAL						30,300	0			

**VALUATION SUMMARY**

VALUE YEAR	2023	2020	2017								
REASON FOR CHANGE	RAPP	RAPP	RAPP								
APPRaised	LAND	30,300	23,600	19,200							
VALUE	IMPR	190,400	163,600	140,900							
	TOTAL	220,700	187,200	160,100							
ASSESSED	LAND	10,610	8,260	6,720							
VALUE	IMPR	66,640	57,260	49,320							
	TOTAL	77,250	65,520	56,040							

<b>OCCUPANCY</b>		<b>EXTERIOR</b>	
<input checked="" type="checkbox"/> SF	<input type="checkbox"/> DU	<input type="checkbox"/> TR	<input type="checkbox"/> WOOD
<input type="checkbox"/> CONVERSION	<input type="checkbox"/> STUCCO		
<b>BUILDING TYPE</b>		<input checked="" type="checkbox"/> ALM/VYNL	
<input type="checkbox"/> MOBILE HOME	<input type="checkbox"/> CONC BLK		
<input type="checkbox"/> BI/TR LEVEL	<input type="checkbox"/> METAL		
<input type="checkbox"/> MOD/MAN	<input checked="" type="checkbox"/> BRICK		
<input type="checkbox"/>	<input type="checkbox"/> STONE		

<b>ROOFING</b>		<b>ROOF TYPE</b>	
<input type="checkbox"/> METAL	<input checked="" type="checkbox"/> GABLE		
<input type="checkbox"/> SLT/TLE	<input type="checkbox"/> HIP		
<input checked="" type="checkbox"/> SHINGLES	<input type="checkbox"/> GAMBREL		
<input type="checkbox"/> SHAKES	<input type="checkbox"/> MANSARD		
<input type="checkbox"/> COMPOSITE	<input type="checkbox"/> FLAT		

<b>FLOORS</b>		B	1	2	3	U
CONCRETE	<input type="checkbox"/>	<input type="checkbox"/>	<input type="checkbox"/>	<input type="checkbox"/>	<input type="checkbox"/>	<input type="checkbox"/>
WOOD	<input type="checkbox"/>	<input type="checkbox"/>	<input type="checkbox"/>	<input type="checkbox"/>	<input type="checkbox"/>	<input type="checkbox"/>
TILE/COMPO	<input type="checkbox"/>	<input checked="" type="checkbox"/>	<input type="checkbox"/>	<input type="checkbox"/>	<input type="checkbox"/>	<input type="checkbox"/>
CARPET	<input type="checkbox"/>	<input checked="" type="checkbox"/>	<input type="checkbox"/>	<input type="checkbox"/>	<input type="checkbox"/>	<input type="checkbox"/>

<b>INT. FINISH</b>		B	1	2	3	U
PLASTER/DW	<input type="checkbox"/>	<input checked="" type="checkbox"/>	<input type="checkbox"/>	<input type="checkbox"/>	<input type="checkbox"/>	<input type="checkbox"/>
PANELING	<input type="checkbox"/>	<input type="checkbox"/>	<input type="checkbox"/>	<input type="checkbox"/>	<input type="checkbox"/>	<input type="checkbox"/>
UNFINISHED	<input type="checkbox"/>	<input type="checkbox"/>	<input type="checkbox"/>	<input type="checkbox"/>	<input type="checkbox"/>	<input type="checkbox"/>

<b>ACCOMMODATIONS</b>				
# OF ROOMS	7			
BEDROOMS	4			
FIREPLACES	1			
<b>HEAT &amp; AC</b>				
B	1	2	3	U

NO HEAT	<input type="checkbox"/>	<input type="checkbox"/>	<input type="checkbox"/>	<input type="checkbox"/>	<input type="checkbox"/>
CTRL HEAT	<input type="checkbox"/>	<input checked="" type="checkbox"/>	<input type="checkbox"/>	<input type="checkbox"/>	<input type="checkbox"/>
HW/STEAM	<input type="checkbox"/>	<input type="checkbox"/>	<input type="checkbox"/>	<input type="checkbox"/>	<input type="checkbox"/>
ELECTRIC	<input type="checkbox"/>	<input type="checkbox"/>	<input type="checkbox"/>	<input type="checkbox"/>	<input type="checkbox"/>
HEAT PUMP	<input type="checkbox"/>	<input checked="" type="checkbox"/>	<input type="checkbox"/>	<input type="checkbox"/>	<input type="checkbox"/>
FLR/WALL	<input type="checkbox"/>	<input type="checkbox"/>	<input type="checkbox"/>	<input type="checkbox"/>	<input type="checkbox"/>
STVE/SPCE	<input type="checkbox"/>	<input type="checkbox"/>	<input type="checkbox"/>	<input type="checkbox"/>	<input type="checkbox"/>
GEO THERMAL	<input type="checkbox"/>	<input type="checkbox"/>	<input type="checkbox"/>	<input type="checkbox"/>	<input type="checkbox"/>
OUTSIDE	<input type="checkbox"/>	<input type="checkbox"/>	<input type="checkbox"/>	<input type="checkbox"/>	<input type="checkbox"/>
CTRL A/C	<input type="checkbox"/>	<input checked="" type="checkbox"/>	<input type="checkbox"/>	<input type="checkbox"/>	<input type="checkbox"/>

<b>PLUMBING</b>		<b>BASE</b>		<input checked="" type="checkbox"/>
X FULL BATH	<input type="checkbox"/>	<input type="checkbox"/>	<input type="checkbox"/>	<input type="checkbox"/>
X HALF BATH	<input type="checkbox"/>	<input type="checkbox"/>	<input type="checkbox"/>	<input type="checkbox"/>
X FIXTURES	<input type="checkbox"/>	<input type="checkbox"/>	<input type="checkbox"/>	<input type="checkbox"/>

FLOOR	AREA	CONST	VALUE
1	2056	FR	237,800
<b>SUBTOTAL</b>			237,800
MULTI-FAMILY #	0		0
BUILDING TYPE	100%		0
BSMT FINISH	0 S.F.		0
FIREPLACE #	1		4,400
HEATING	0 S.F.		0
AIR COND	2,056 S.F.		3,390
PLUMBING #	0		0
GARAGES & CARPORTS			13,600
EXTRA FEATURES			6,500
<b>SUBTOTAL</b>			265,690
GRADE FACTOR			105 %
<b>UNADJUSTED VALUE</b>			278,970
FACTOR			100 %

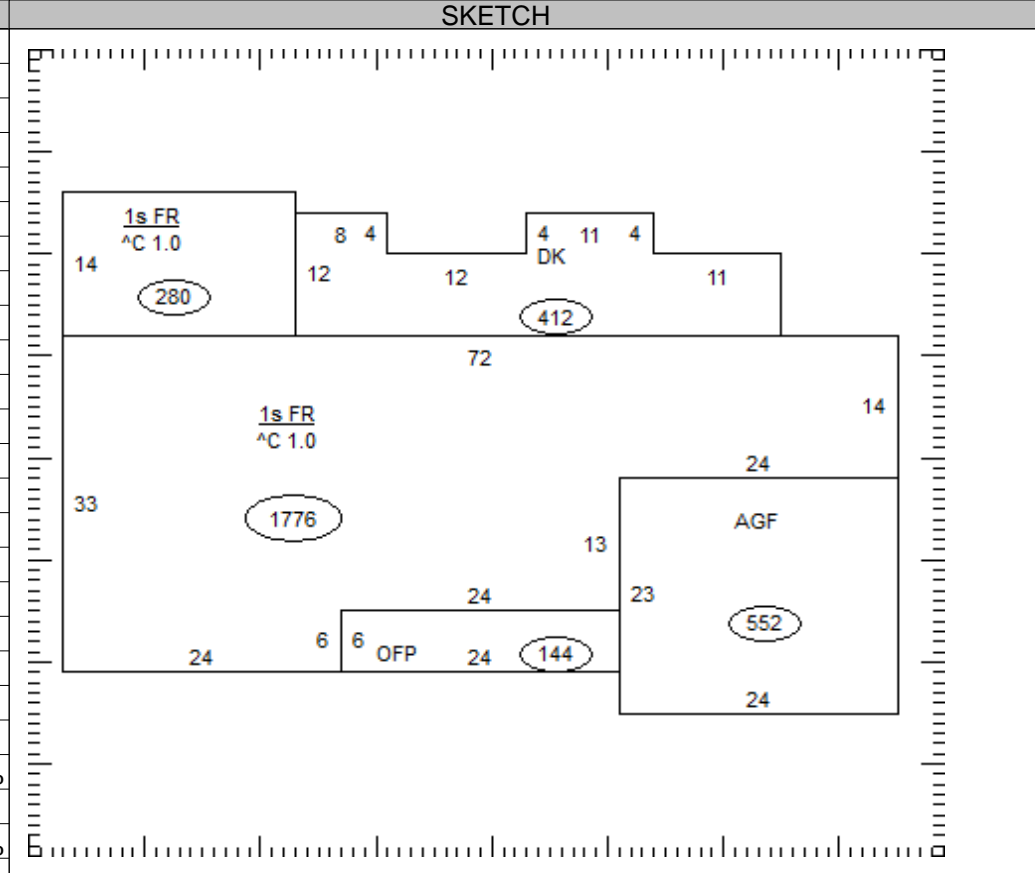

OCCUPANCY	ST.HT	SIZE	AREA	GRADE	PRICE	AGE	REMD	CND	UNADJ VAL	PHYS	PHYS VAL	FUNC	TRUE VAL
DWELLING	1	SK	2,056	C+		1977		A	278,970	35	181,330		190,400
1													
2													
3													
4													
5													
6													
7													
8													
9													
10													
11													

05-151800.0000 TOTAL 190,400

**COMMENTS**

MAIN FRAME w/MS  
Dwelling has an Economic Factor of 105%

BUTLER TWP-COLDWATER CORP / COLDWATER SD  
08-28-377-003

Property Class: 510

Neighborhood  
000508-TS50

Map: 14B5  
Block:  
Card: 11

Bk: Pg:

05-151800.0000

**JRNR SOLUTIONS LLC**  
JRNR SOLUTIONS LLC  
618 RAY DR  
COLDWATER, OH 45828

**LEGAL INFORMATION**  
SELHORST THIRTEENTH ADD  
  
LOT#: 1111

	OWNERSHIP	ADDRESS	CITY	STATE	ZIP	DATE	AMOUNT	DEED:CONV#	JS	VALID
1	VANDENBOSCH LOUDONNA C	313 WOODVIEW DR	COLDWATER	OH	45828	12/23/1997	118,000	: A : 0	<input type="checkbox"/>	<input checked="" type="checkbox"/>
2							0	0	<input type="checkbox"/>	<input type="checkbox"/>
3							0	0	<input type="checkbox"/>	<input type="checkbox"/>

X:  TTO LISTER: NS DATE: 01/14/2005 TIME: 12:00:00 AM  LETTER  LETTER REC'D GIS CODE

STREET/ROAD	TOPOGRAPHY	PU-UTILITIES-PR	NEIGHBORHOOD	INFLUENCE FACTORS	PROPERTY LOCATION	
<input checked="" type="checkbox"/> PAVED <input type="checkbox"/> GRAVEL <input type="checkbox"/> DIRT <input checked="" type="checkbox"/> SIDEWALKS <input type="checkbox"/> CURBS	<input checked="" type="checkbox"/> LEVEL <input type="checkbox"/> HIGH <input type="checkbox"/> LOW <input type="checkbox"/> ROLLING <input type="checkbox"/> STANDARD	<input type="checkbox"/> WATER <input type="checkbox"/> SEWER <input type="checkbox"/> GAS <input type="checkbox"/> ELECTRIC <input checked="" type="checkbox"/> STANDARD	<input type="checkbox"/> IMPROVING <input type="checkbox"/> STATIC <input type="checkbox"/> DECLINING <input type="checkbox"/> OLD <input type="checkbox"/> STANDARD	<input type="checkbox"/> A. NO ROAD <input type="checkbox"/> B. TOPGRHY <input type="checkbox"/> C. Ex Front <input type="checkbox"/> D. QUANTITY <input type="checkbox"/> E. SZ/SHAPE	<input type="checkbox"/> F. RESTRICT <input type="checkbox"/> G. WOOD LT <input type="checkbox"/> H. VACANCY <input type="checkbox"/> I. WATER FRONT <input type="checkbox"/> J. OTHER/CDU	313 WOODVIEW DR, COLDWATER COMMENT

LAND COMPUTATIONS							
LAND TYPE	SIZE	M	RATE	C	INF	M	VALUE C
TOTAL						30,300	0

**VALUATION SUMMARY**

VALUE YEAR	REASON FOR CHANGE	APPRaised	IMPR	TOTAL	ASSESSED	IMPR	TOTAL

OCCUPANCY	EXTERIOR	FLOOR	AREA	CONST	VALUE
<input type="checkbox"/> SF <input type="checkbox"/> DU <input type="checkbox"/> TR	<input type="checkbox"/> WOOD				
<input type="checkbox"/> CONVERSION	<input type="checkbox"/> STUCCO				
<b>BUILDING TYPE</b>	<input type="checkbox"/> ALM/VYNL				
<input type="checkbox"/> MOBILE HOME	<input type="checkbox"/> CONC BLK				
<input type="checkbox"/> BI/TR LEVEL	<input type="checkbox"/> METAL				
<input type="checkbox"/> MOD/MAN	<input type="checkbox"/> BRICK				
<input type="checkbox"/>	<input type="checkbox"/> STONE				
ROOFING	ROOF TYPE				
<input type="checkbox"/> METAL	<input type="checkbox"/> GABLE				
<input type="checkbox"/> SLT/TLE	<input type="checkbox"/> HIP				
<input type="checkbox"/> SHINGLES	<input type="checkbox"/> GAMBREL				
<input type="checkbox"/> SHAKES	<input type="checkbox"/> MANSARD				
<input type="checkbox"/> COMPOSITE	<input type="checkbox"/> FLAT				

SUBTOTAL			0
MULTI-FAMILY #	0		0
BUILDING TYPE	000%		0
BSMT FINISH	0 S.F.		0
FIREPLACE #	0		0
HEATING	0 S.F.		0
AIR COND	0 S.F.		0
PLUMBING #	0		0
GARAGES & CARPORTS			0
EXTRA FEATURES			0
SUBTOTAL			0
GRADE FACTOR			%
UNADJUSTED VALUE			0
FACTOR			%

FLOORS	B	1	2	3	U
CONCRETE	<input type="checkbox"/>	<input type="checkbox"/>	<input type="checkbox"/>	<input type="checkbox"/>	<input type="checkbox"/>
WOOD	<input type="checkbox"/>	<input type="checkbox"/>	<input type="checkbox"/>	<input type="checkbox"/>	<input type="checkbox"/>
TILE/COMPO	<input type="checkbox"/>	<input type="checkbox"/>	<input type="checkbox"/>	<input type="checkbox"/>	<input type="checkbox"/>
CARPET	<input type="checkbox"/>	<input type="checkbox"/>	<input type="checkbox"/>	<input type="checkbox"/>	<input type="checkbox"/>
INT. FINISH	B	1	2	3	U
PLASTER/DW	<input type="checkbox"/>	<input type="checkbox"/>	<input type="checkbox"/>	<input type="checkbox"/>	<input type="checkbox"/>
PANELING	<input type="checkbox"/>	<input type="checkbox"/>	<input type="checkbox"/>	<input type="checkbox"/>	<input type="checkbox"/>
UNFINISHED	<input type="checkbox"/>	<input type="checkbox"/>	<input type="checkbox"/>	<input type="checkbox"/>	<input type="checkbox"/>
ACCOMMODATIONS					
# OF ROOMS					
BEDROOMS					
FIREPLACES					
HEAT & AC	B	1	2	3	U
NO HEAT	<input type="checkbox"/>	<input type="checkbox"/>	<input type="checkbox"/>	<input type="checkbox"/>	<input type="checkbox"/>
CTRL HEAT	<input type="checkbox"/>	<input type="checkbox"/>	<input type="checkbox"/>	<input type="checkbox"/>	<input type="checkbox"/>
HW/STEAM	<input type="checkbox"/>	<input type="checkbox"/>	<input type="checkbox"/>	<input type="checkbox"/>	<input type="checkbox"/>
ELECTRIC	<input type="checkbox"/>	<input type="checkbox"/>	<input type="checkbox"/>	<input type="checkbox"/>	<input type="checkbox"/>
HEAT PUMP	<input type="checkbox"/>	<input type="checkbox"/>	<input type="checkbox"/>	<input type="checkbox"/>	<input type="checkbox"/>
FLR/WALL	<input type="checkbox"/>	<input type="checkbox"/>	<input type="checkbox"/>	<input type="checkbox"/>	<input type="checkbox"/>
STVE/SPCE	<input type="checkbox"/>	<input type="checkbox"/>	<input type="checkbox"/>	<input type="checkbox"/>	<input type="checkbox"/>
GEO THERMAL	<input type="checkbox"/>	<input type="checkbox"/>	<input type="checkbox"/>	<input type="checkbox"/>	<input type="checkbox"/>
OUTSIDE	<input type="checkbox"/>	<input type="checkbox"/>	<input type="checkbox"/>	<input type="checkbox"/>	<input type="checkbox"/>
CTRL A/C	<input type="checkbox"/>	<input type="checkbox"/>	<input type="checkbox"/>	<input type="checkbox"/>	<input type="checkbox"/>
PLUMBING	BASE <input type="checkbox"/>				
X FULL BATH					
X HALF BATH					
X FIXTURES					

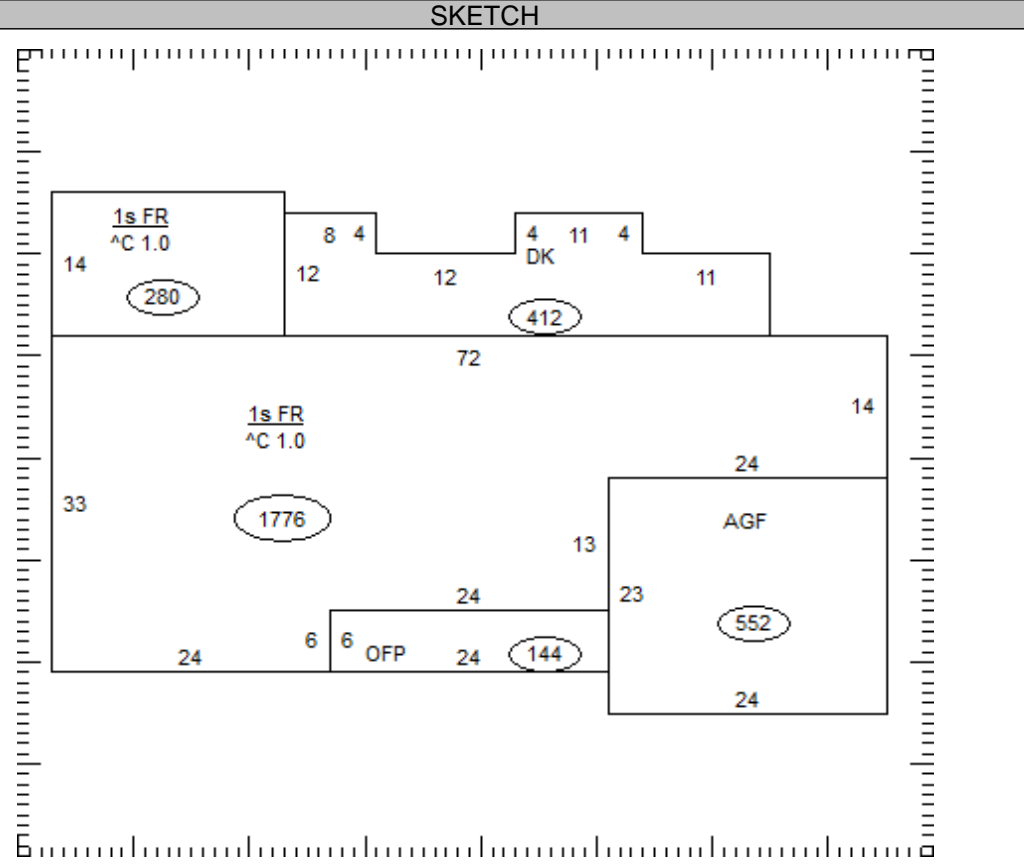

OCCUPANCY	ST.HT	SIZE	AREA	GRADE	PRICE	AGE	REMD	CND	UNADJ VAL	PHYS	PHYS VAL	FUNC	TRUE VAL
DWELLING		SK											
1													
2													
3													
4													
5													
6													
7													
8													
9													
10													
11													

05-151800.0000

**TOTAL** 0

**COMMENTS**