

BUTLER TWP-COLDWATER CORP / COLDWATER SD
 08-28-451-015

Property Class: 510
 Neighborhood
 000506-TS50
 Map: 14B9
 Block:
 Card: 49
 Bk: Pg:

05-111600.0000

LEGAL INFORMATION
 SELHORST FOURTH ADDITION

LOT#: 728

STACHLER SHAWN
 STACHLER SHAWN
 620 PLUM ST
 COLDWATER, OH 45828

	OWNERSHIP	ADDRESS	CITY	STATE	ZIP	DATE	AMOUNT	DEED:CONV#	JS	VALID
1	STACHLER SHAWN	620 PLUM ST	COLDWATER	OH	45828	10/24/2019	179,900	WDC : 722	<input type="checkbox"/>	<input checked="" type="checkbox"/>
2	BORGER STEVEN M &	620 PLUM DR	COLDWATER	OH	45828	12/10/2014	0	QCE : X : 0	<input type="checkbox"/>	<input type="checkbox"/>
3	BORGER STEVEN	620 PLUM DR	COLDWATER	OH	45828	10/13/2009	85,000	WDC : A : 599	<input type="checkbox"/>	<input type="checkbox"/>

X: TTO LISTER: NS DATE: 01/21/2005 TIME: 12:00:00 AM LETTER LETTER REC'D GIS CODE

STREET/ROAD	TOPOGRAPHY	PU-UTILITIES-PR	NEIGHBORHOOD	INFLUENCE FACTORS		PROPERTY LOCATION	
<input checked="" type="checkbox"/> PAVED <input type="checkbox"/> GRAVEL <input type="checkbox"/> DIRT <input checked="" type="checkbox"/> SIDEWALKS <input type="checkbox"/> CURBS	<input checked="" type="checkbox"/> LEVEL <input type="checkbox"/> HIGH <input type="checkbox"/> LOW <input type="checkbox"/> ROLLING <input type="checkbox"/> STANDARD	<input type="checkbox"/> WATER <input type="checkbox"/> SEWER <input type="checkbox"/> GAS <input type="checkbox"/> ELECTRIC <input checked="" type="checkbox"/> STANDARD	<input type="checkbox"/> IMPROVING <input checked="" type="checkbox"/> STATIC <input type="checkbox"/> DECLINING <input type="checkbox"/> OLD <input type="checkbox"/> STANDARD	<input type="checkbox"/> A. NO ROAD <input type="checkbox"/> B. TOPGRHY <input type="checkbox"/> C. Ex Front <input type="checkbox"/> D. QUANTITY <input type="checkbox"/> E. SZ/SHAPE	<input type="checkbox"/> F. RESTRICT <input type="checkbox"/> G. WOOD LT <input type="checkbox"/> H. VACANCY <input type="checkbox"/> I. WATER FRONT <input type="checkbox"/> J. OTHER/CDU	620 PLUM DR, COLDWATER COMMENT TY2022:Net Gen=\$1,961.90, Other Assessment=\$0.00 DE16 DESKTOP REVIEW CHG: cor pat msmnts. chg BRK to FR, chg ofp to stp DE20 RMV OWN OCC; DIDN'T RET APP	
LAND COMPUTATIONS							
LAND TYPE	SIZE	M	RATE	C	INF	M VALUE	C
F:Front	F70 D130	ST440	DP93	ADJ409		28,600	0
TOTAL						28,600	0

VALUATION SUMMARY

VALUE YEAR	2023	2020	2017
REASON FOR CHANGE	RAPP	RAPP	RAPP
APPRAISED VALUE	28,600	20,300	16,900
<u>LAND</u>	159,000	128,600	103,600
<u>IMPR</u>	187,600	148,900	120,500
<u>TOTAL</u>			
ASSESSED VALUE	10,010	7,110	5,920
<u>LAND</u>	55,650	45,010	36,260
<u>IMPR</u>	65,660	52,120	42,180
<u>TOTAL</u>			

OCCUPANCY		EXTERIOR	
<input checked="" type="checkbox"/> SF	<input type="checkbox"/> DU	<input type="checkbox"/> WOOD	<input type="checkbox"/> STUCCO
<input type="checkbox"/> TR	<input type="checkbox"/> CONVERSION	<input type="checkbox"/> ALM/VYNL	<input type="checkbox"/> CONC BLK
BUILDING TYPE		<input type="checkbox"/> METAL	<input type="checkbox"/> BRICK
<input type="checkbox"/> MOBILE HOME	<input type="checkbox"/> BI/TR LEVEL	<input type="checkbox"/> BRICK	<input type="checkbox"/> STONE
<input type="checkbox"/> MOD/MAN	<input type="checkbox"/>		

ROOFING		ROOF TYPE	
<input type="checkbox"/> METAL	<input checked="" type="checkbox"/> GABLE	<input type="checkbox"/> HIP	<input type="checkbox"/> GAMBREL
<input type="checkbox"/> SLT/TLE	<input type="checkbox"/> SHINGLES	<input type="checkbox"/> MANSARD	<input type="checkbox"/> FLAT
<input type="checkbox"/> SHAKES	<input type="checkbox"/> COMPOSITE		

FLOORS		B	1	2	3	U
CONCRETE	<input checked="" type="checkbox"/>	<input type="checkbox"/>	<input type="checkbox"/>	<input type="checkbox"/>	<input type="checkbox"/>	<input type="checkbox"/>
WOOD	<input type="checkbox"/>	<input type="checkbox"/>	<input type="checkbox"/>	<input type="checkbox"/>	<input type="checkbox"/>	<input type="checkbox"/>
TILE/COMPO	<input type="checkbox"/>	<input checked="" type="checkbox"/>	<input type="checkbox"/>	<input type="checkbox"/>	<input type="checkbox"/>	<input type="checkbox"/>
CARPET	<input checked="" type="checkbox"/>	<input checked="" type="checkbox"/>	<input type="checkbox"/>	<input type="checkbox"/>	<input type="checkbox"/>	<input type="checkbox"/>

INT. FINISH		B	1	2	3	U
PLASTER/DW	<input type="checkbox"/>	<input checked="" type="checkbox"/>	<input type="checkbox"/>	<input type="checkbox"/>	<input type="checkbox"/>	<input type="checkbox"/>
PANELING	<input checked="" type="checkbox"/>	<input type="checkbox"/>	<input type="checkbox"/>	<input type="checkbox"/>	<input type="checkbox"/>	<input type="checkbox"/>
UNFINISHED	<input checked="" type="checkbox"/>	<input type="checkbox"/>	<input type="checkbox"/>	<input type="checkbox"/>	<input type="checkbox"/>	<input type="checkbox"/>

ACCOMMODATIONS						
# OF ROOMS		6				
BEDROOMS		3				
FIREPLACES						

HEAT & AC		B	1	2	3	U
NO HEAT	<input type="checkbox"/>	<input type="checkbox"/>	<input type="checkbox"/>	<input type="checkbox"/>	<input type="checkbox"/>	<input type="checkbox"/>
CTRL HEAT	<input type="checkbox"/>	<input checked="" type="checkbox"/>	<input type="checkbox"/>	<input type="checkbox"/>	<input type="checkbox"/>	<input type="checkbox"/>
HW/STEAM	<input type="checkbox"/>	<input type="checkbox"/>	<input type="checkbox"/>	<input type="checkbox"/>	<input type="checkbox"/>	<input type="checkbox"/>
ELECTRIC	<input type="checkbox"/>	<input type="checkbox"/>	<input type="checkbox"/>	<input type="checkbox"/>	<input type="checkbox"/>	<input type="checkbox"/>
HEAT PUMP	<input type="checkbox"/>	<input type="checkbox"/>	<input type="checkbox"/>	<input type="checkbox"/>	<input type="checkbox"/>	<input type="checkbox"/>
FLR/WALL	<input type="checkbox"/>	<input type="checkbox"/>	<input type="checkbox"/>	<input type="checkbox"/>	<input type="checkbox"/>	<input type="checkbox"/>
STVE/SPCE	<input type="checkbox"/>	<input type="checkbox"/>	<input type="checkbox"/>	<input type="checkbox"/>	<input type="checkbox"/>	<input type="checkbox"/>
GEOHERMAL	<input type="checkbox"/>	<input type="checkbox"/>	<input type="checkbox"/>	<input type="checkbox"/>	<input type="checkbox"/>	<input type="checkbox"/>
OUTSIDE	<input type="checkbox"/>	<input type="checkbox"/>	<input type="checkbox"/>	<input type="checkbox"/>	<input type="checkbox"/>	<input type="checkbox"/>
CTRL A/C	<input type="checkbox"/>	<input checked="" type="checkbox"/>	<input type="checkbox"/>	<input type="checkbox"/>	<input type="checkbox"/>	<input type="checkbox"/>

PLUMBING		BASE			
X FULL BATH					
X HALF BATH		1			
X FIXTURES					

FLOOR	AREA	CONST	VALUE
1	1465	FR	199,010
BSMT	1107		15,830
SUBTOTAL			214,840
MULTI-FAMILY #	0		0
BUILDING TYPE	100%		0
BSMT FINISH	0 S.F.		0
FIREPLACE #	0		0
HEATING	0 S.F.		0
AIR COND	1,465 S.F.		2,420
PLUMBING #	2		2,420
GARAGES & CARPORTS			10,600
EXTRA FEATURES			8,100
SUBTOTAL			238,380
GRADE FACTOR			100 %
UNADJUSTED VALUE			238,380
FACTOR			100 %

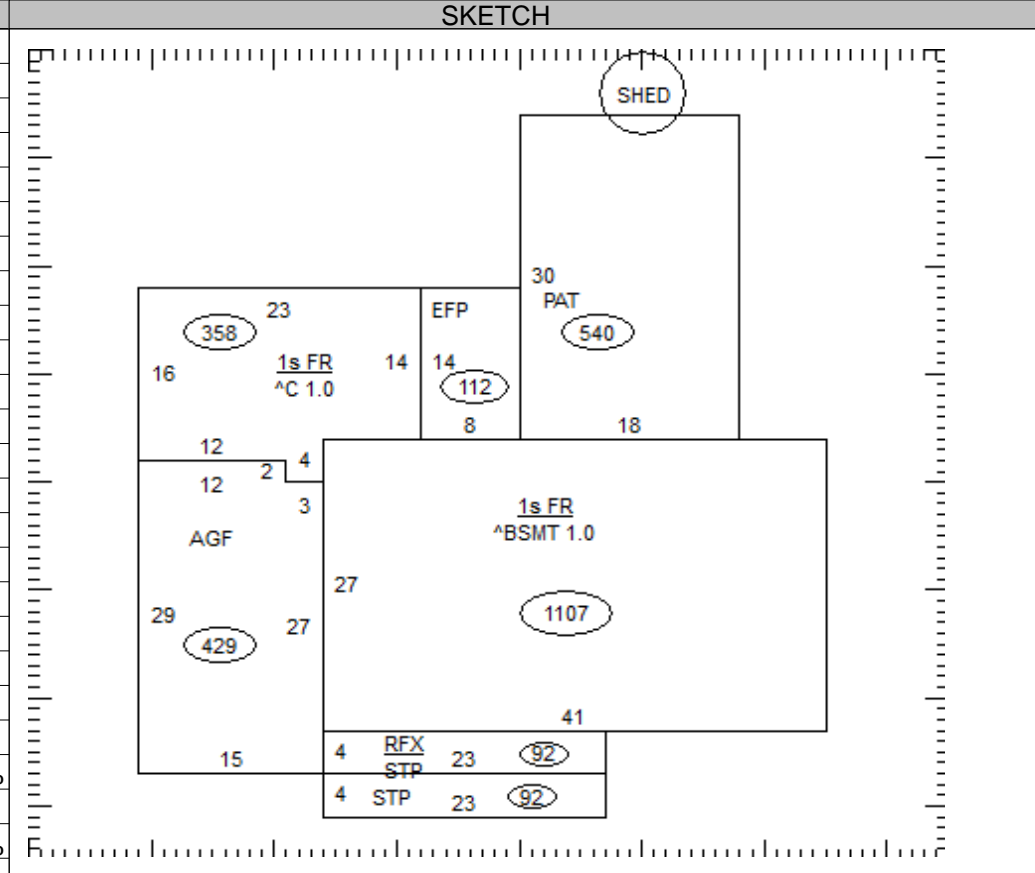

OCCUPANCY	ST.HT	SIZE	AREA	GRADE	PRICE	AGE	REMD	CND	UNADJ VAL	PHYS	PHYS VAL	FUNC	TRUE VAL
DWELLING	1	SK	1,465	C		1958		A	238,380	42	138,260		159,000
1 Shed	PP	10x14	140	C		2010		A		21			0
2													
3													
4													
5													
6													
7													
8													
9													
10													
11													

05-111600.0000 TOTAL 159,000

COMMENTS

Dwelling has an Economic Factor of 115%

BUTLER TWP-COLDWATER CORP / COLDWATER SD
08-28-451-015

Property Class: 510
Neighborhood
000506-TS50
Map: 14B9
Block:
Card: 49
Bk: Pg:

05-111600.0000

STACHLER SHAWN
STACHLER SHAWN
620 PLUM ST
COLDWATER, OH 45828

LEGAL INFORMATION
SELHORST FOURTH ADDITION

LOT#: 728

	OWNERSHIP	ADDRESS	CITY	STATE	ZIP	DATE	AMOUNT	DEED:CONV#	JS	VALID
1	DEUTSCHE BANK NATIONAL	350 S GRAND 47TH FLOOR	LOS ANGELES	CA	90071	04/23/2009	85,000	SHC : S : 210	<input type="checkbox"/>	<input type="checkbox"/>
2	KREMER DAVID J & KELLY I	620 PLUM DR	COLDWATER	OH	45828	04/23/2004	81,500	WDC : A : 0	<input type="checkbox"/>	<input checked="" type="checkbox"/>
3	EWRY JOHN W & ROSEMARY	620 PLUM DR	COLDWATER	OH	45828		0	: 0	<input type="checkbox"/>	<input type="checkbox"/>

X:	<input type="checkbox"/> TTO	LISTER: NS	DATE: 01/21/2005	TIME: 12:00:00 AM	<input type="checkbox"/> LETTER	<input type="checkbox"/> LETTER REC'D	GIS CODE
----	------------------------------	------------	------------------	-------------------	---------------------------------	---------------------------------------	----------

STREET/ROAD	TOPOGRAPHY	PU-UTILITIES-PR	NEIGHBORHOOD	INFLUENCE FACTORS				PROPERTY LOCATION	
<input checked="" type="checkbox"/> PAVED <input type="checkbox"/> GRAVEL <input type="checkbox"/> DIRT <input checked="" type="checkbox"/> SIDEWALKS <input type="checkbox"/> CURBS	<input checked="" type="checkbox"/> LEVEL <input type="checkbox"/> HIGH <input type="checkbox"/> LOW <input type="checkbox"/> ROLLING <input type="checkbox"/> STANDARD	<input type="checkbox"/> WATER <input type="checkbox"/> SEWER <input type="checkbox"/> GAS <input type="checkbox"/> ELECTRIC <input checked="" type="checkbox"/> STANDARD	<input type="checkbox"/> IMPROVING <input checked="" type="checkbox"/> STATIC <input type="checkbox"/> DECLINING <input type="checkbox"/> OLD <input type="checkbox"/> STANDARD	<input type="checkbox"/> A. NO ROAD <input type="checkbox"/> B. TOPGRHY <input type="checkbox"/> C. Ex Front <input type="checkbox"/> D. QUANTITY <input type="checkbox"/> E. SZ/SHAPE	<input type="checkbox"/> F. RESTRICT <input type="checkbox"/> G. WOOD LT <input type="checkbox"/> H. VACANCY <input type="checkbox"/> I. WATER FRONT <input type="checkbox"/> J. OTHER/CDU	620 PLUM DR, COLDWATER			
								COMMENT	

LAND COMPUTATIONS							
LAND TYPE	SIZE	M	RATE	C	INF	M	VALUE C
TOTAL						28,600	0

VALUATION SUMMARY

VALUE YEAR							
REASON FOR CHANGE							
APPRaised	<u>LAND</u>						
VALUE	<u>IMPR</u>						
	<u>TOTAL</u>						
ASSESSED	<u>LAND</u>						
VALUE	<u>IMPR</u>						
	<u>TOTAL</u>						

OCCUPANCY
 SF DU TR
 CONVERSION
BUILDING TYPE
 MOBILE HOME
 BI/TR LEVEL
 MOD/MAN

OCCUPANCY	EXTERIOR	FLOOR	AREA	CONST	VALUE
	<input type="checkbox"/> WOOD				
	<input type="checkbox"/> STUCCO				
	<input type="checkbox"/> ALM/VYNL				
	<input type="checkbox"/> CONC BLK				
	<input type="checkbox"/> METAL				
	<input type="checkbox"/> BRICK				
	<input type="checkbox"/> STONE				

ROOFING
 METAL
 SLT/TLE
 SHINGLES
 SHAKES
 COMPOSITE

ROOF TYPE		
<input type="checkbox"/> GABLE		
<input type="checkbox"/> HIP		
<input type="checkbox"/> GAMBREL		
<input type="checkbox"/> MANSARD		
<input type="checkbox"/> FLAT		
SUBTOTAL		0
MULTI-FAMILY #	0	0
BUILDING TYPE	000%	0
BSMT FINISH	0 S.F.	0
FIREPLACE #	0	0
HEATING	0 S.F.	0
AIR COND	0 S.F.	0
PLUMBING #	0	0
GARAGES & CARPORTS		0
EXTRA FEATURES		0
SUBTOTAL		0
GRADE FACTOR		%
UNADJUSTED VALUE		0
FACTOR		%

FLOORS B 1 2 3 U
 CONCRETE
 WOOD
 TILE/COMPO
 CARPET

INT. FINISH B 1 2 3 U
 PLASTER/DW
 PANELING
 UNFINISHED

ACCOMMODATIONS
 # OF ROOMS
 BEDROOMS
 FIREPLACES
 HEAT & AC B 1 2 3 U

NO HEAT
 CTRL HEAT
 HW/STEAM
 ELECTRIC
 HEAT PUMP
 FLR/WALL
 STVE/SPCE
 GEOTHERMAL
 OUTSIDE
 CTRL A/C
 PLUMBING BASE

X FULL BATH
 X HALF BATH
 X FIXTURES

OCCUPANCY	ST.HT	SIZE	AREA	GRADE	PRICE	AGE	REMD	CND	UNADJ VAL	PHYS	PHYS VAL	FUNC	TRUE VAL
DWELLING		SK											
1													
2													
3													
4													
5													
6													
7													
8													
9													
10													
11													

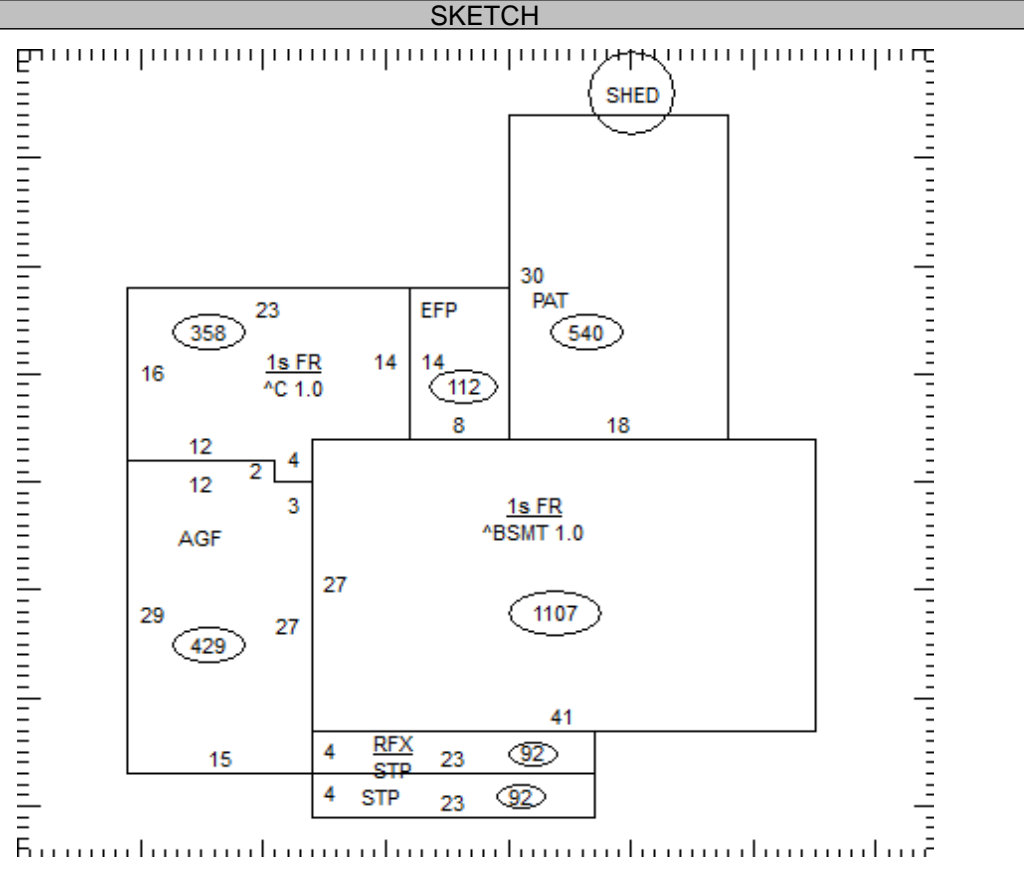

05-111600.0000

TOTAL 0

COMMENTS