

05-100300.0000

**SPRIGGS RYAN M & AMY M**  
SPRIGGS RYAN M & AMY M  
507 W VINE ST  
COLDWATER, OH 45828

BUTLER TWP-COLDWATER CORP / COLDWATER SD  
08-28-454-002

**LEGAL INFORMATION**  
SELHORST SECOND ADDITION  
  
RTS: 000-00-00 LOT#: 615

	OWNERSHIP	ADDRESS	CITY	STATE	ZIP	DATE	AMOUNT	DEED:CONV#	JS	VALID
1	SPRIGGS RYAN M & AMY M	507 W VINE ST	COLDWATER	OH	45828	08/17/2021	265,000	SUC : 678	<input type="checkbox"/>	<input checked="" type="checkbox"/>
2	BELLANDO EDWARD J &	507 W VINE ST	COLDWATER	OH	45828	06/30/1995	78,000	: A : 0	<input type="checkbox"/>	<input checked="" type="checkbox"/>
3							0	0	<input type="checkbox"/>	<input type="checkbox"/>

X:  TTO      LISTER: JL      DATE: 02/03/2012      TIME: 12:00:00 AM       LETTER       LETTER REC'D      GIS CODE

STREET/ROAD	TOPOGRAPHY	PU-UTILITIES-PR	NEIGHBORHOOD	INFLUENCE FACTORS			PROPERTY LOCATION
<input checked="" type="checkbox"/> PAVED <input type="checkbox"/> GRAVEL <input type="checkbox"/> DIRT <input checked="" type="checkbox"/> SIDEWALKS <input type="checkbox"/> CURBS	<input checked="" type="checkbox"/> LEVEL <input type="checkbox"/> HIGH <input type="checkbox"/> LOW <input type="checkbox"/> ROLLING <input type="checkbox"/> STANDARD	<input type="checkbox"/> WATER <input type="checkbox"/> SEWER <input type="checkbox"/> GAS <input type="checkbox"/> ELECTRIC <input checked="" type="checkbox"/> STANDARD	<input type="checkbox"/> IMPROVING <input checked="" type="checkbox"/> STATIC <input type="checkbox"/> DECLINING <input type="checkbox"/> OLD <input type="checkbox"/> STANDARD	<input type="checkbox"/> A. NO ROAD <input type="checkbox"/> B. TOPGRHY <input type="checkbox"/> C. Ex Front <input type="checkbox"/> D. QUANTITY <input type="checkbox"/> E. SZ/SHAPE	<input type="checkbox"/> F. RESTRICT <input type="checkbox"/> G. WOOD LT <input type="checkbox"/> H. VACANCY <input type="checkbox"/> I. WATER FRONT <input type="checkbox"/> J. OTHER/CDU	507 W VINE ST, COLDWATER	

COMMENT  
TY2022:Net Gen=\$2,446.74, Other Assessment=\$0.00  
DE12 ADD ADDTN  
DE09 RMV PORTION OF BSMNT-DATA MAILER  
DE16 DESKTOP REVIEW CHG: cor pat msmnts  
DE22 RMV OWN OCC - DID NOT RETURN APP

LAND COMPUTATIONS					
LAND TYPE	SIZE	M	RATE	C	
F:Front	F68 D122	ST440	DP90	ADJ396	
TOTAL					26,900 0

VALUATION SUMMARY

VALUE YEAR	2023	2020	2017					
REASON FOR CHANGE	RAPP	RAPP	RAPP					
APPRAISED VALUE	<u>LAND</u> 26,900 <u>IMPR</u> 199,200 <u>TOTAL</u> 226,100	19,100 166,600 185,700	15,900 132,600 148,500					
ASSESSED VALUE	<u>LAND</u> 9,420 <u>IMPR</u> 69,720 <u>TOTAL</u> 79,140	6,690 58,310 65,000	5,570 46,410 51,980					

OCCUPANCY	EXTERIOR	FLOOR	AREA	CONST	VALUE
<input checked="" type="checkbox"/> SF <input type="checkbox"/> DU <input type="checkbox"/> TR	<input checked="" type="checkbox"/> WOOD	1	483	BRK	70,200
<input type="checkbox"/> CONVERSION	<input type="checkbox"/> STUCCO	1	980	FR	133,120
<b>BUILDING TYPE</b>	<input checked="" type="checkbox"/> ALM/VYNL	.25	221	FR	27,380
<input type="checkbox"/> MOBILE HOME	<input type="checkbox"/> CONC BLK	.5	299	FR	25,180
<input type="checkbox"/> BI/TR LEVEL	<input type="checkbox"/> METAL				
<input type="checkbox"/> MOD/MAN	<input checked="" type="checkbox"/> BRICK				
<input type="checkbox"/>	<input type="checkbox"/> STONE				

ROOFING	ROOF TYPE
<input type="checkbox"/> METAL	<input checked="" type="checkbox"/> GABLE
<input type="checkbox"/> SLT/TLE	<input type="checkbox"/> HIP
<input checked="" type="checkbox"/> SHINGLES	<input type="checkbox"/> GAMBREL
<input type="checkbox"/> SHAKES	<input type="checkbox"/> MANSARD
<input type="checkbox"/> COMPOSITE	<input type="checkbox"/> FLAT

FLOORS	B	1	2	3	U
CONCRETE	<input checked="" type="checkbox"/>	<input type="checkbox"/>	<input type="checkbox"/>	<input type="checkbox"/>	<input type="checkbox"/>
WOOD	<input type="checkbox"/>	<input type="checkbox"/>	<input type="checkbox"/>	<input type="checkbox"/>	<input type="checkbox"/>
TILE/COMPO	<input type="checkbox"/>	<input checked="" type="checkbox"/>	<input checked="" type="checkbox"/>	<input type="checkbox"/>	<input type="checkbox"/>
CARPET	<input type="checkbox"/>	<input checked="" type="checkbox"/>	<input checked="" type="checkbox"/>	<input checked="" type="checkbox"/>	<input checked="" type="checkbox"/>
INT. FINISH	B	1	2	3	U
PLASTER/DW	<input type="checkbox"/>	<input checked="" type="checkbox"/>	<input checked="" type="checkbox"/>	<input checked="" type="checkbox"/>	<input checked="" type="checkbox"/>
PANELING	<input type="checkbox"/>	<input type="checkbox"/>	<input type="checkbox"/>	<input type="checkbox"/>	<input type="checkbox"/>
UNFINISHED	<input type="checkbox"/>	<input type="checkbox"/>	<input type="checkbox"/>	<input type="checkbox"/>	<input type="checkbox"/>
ACCOMMODATIONS					
# OF ROOMS		6		3	
BEDROOMS		1		3	
FIREPLACES		1			
HEAT & AC	B	1	2	3	U
NO HEAT	<input type="checkbox"/>	<input type="checkbox"/>	<input type="checkbox"/>	<input type="checkbox"/>	<input type="checkbox"/>
CTRL HEAT	<input type="checkbox"/>	<input checked="" type="checkbox"/>	<input checked="" type="checkbox"/>	<input checked="" type="checkbox"/>	<input checked="" type="checkbox"/>
HW/STEAM	<input type="checkbox"/>	<input type="checkbox"/>	<input type="checkbox"/>	<input type="checkbox"/>	<input type="checkbox"/>
ELECTRIC	<input type="checkbox"/>	<input type="checkbox"/>	<input type="checkbox"/>	<input type="checkbox"/>	<input type="checkbox"/>
HEAT PUMP	<input type="checkbox"/>	<input type="checkbox"/>	<input type="checkbox"/>	<input type="checkbox"/>	<input type="checkbox"/>
FLR/WALL	<input type="checkbox"/>	<input type="checkbox"/>	<input type="checkbox"/>	<input type="checkbox"/>	<input type="checkbox"/>
STVE/SPCE	<input type="checkbox"/>	<input type="checkbox"/>	<input type="checkbox"/>	<input type="checkbox"/>	<input type="checkbox"/>
GEO THERMAL	<input type="checkbox"/>	<input type="checkbox"/>	<input type="checkbox"/>	<input type="checkbox"/>	<input type="checkbox"/>
OUTSIDE	<input type="checkbox"/>	<input type="checkbox"/>	<input type="checkbox"/>	<input type="checkbox"/>	<input type="checkbox"/>
CTRL A/C	<input type="checkbox"/>	<input checked="" type="checkbox"/>	<input checked="" type="checkbox"/>	<input checked="" type="checkbox"/>	<input checked="" type="checkbox"/>
PLUMBING					
X FULL BATH		1			
X HALF BATH		1			
X FIXTURES					

BSMT	980		14,010
<b>SUBTOTAL</b>			269,890
MULTI-FAMILY #	0		0
BUILDING TYPE	100%		0
BSMT FINISH	0 S.F.		0
FIREPLACE #	1		4,400
HEATING	0 S.F.		0
AIR COND	1,983 S.F.		3,270
PLUMBING #	5		6,050
GARAGES & CARPORTS			8,200
EXTRA FEATURES			5,900
<b>SUBTOTAL</b>			297,710
GRADE FACTOR			105 %
<b>UNADJUSTED VALUE</b>			312,600
FACTOR			100 %

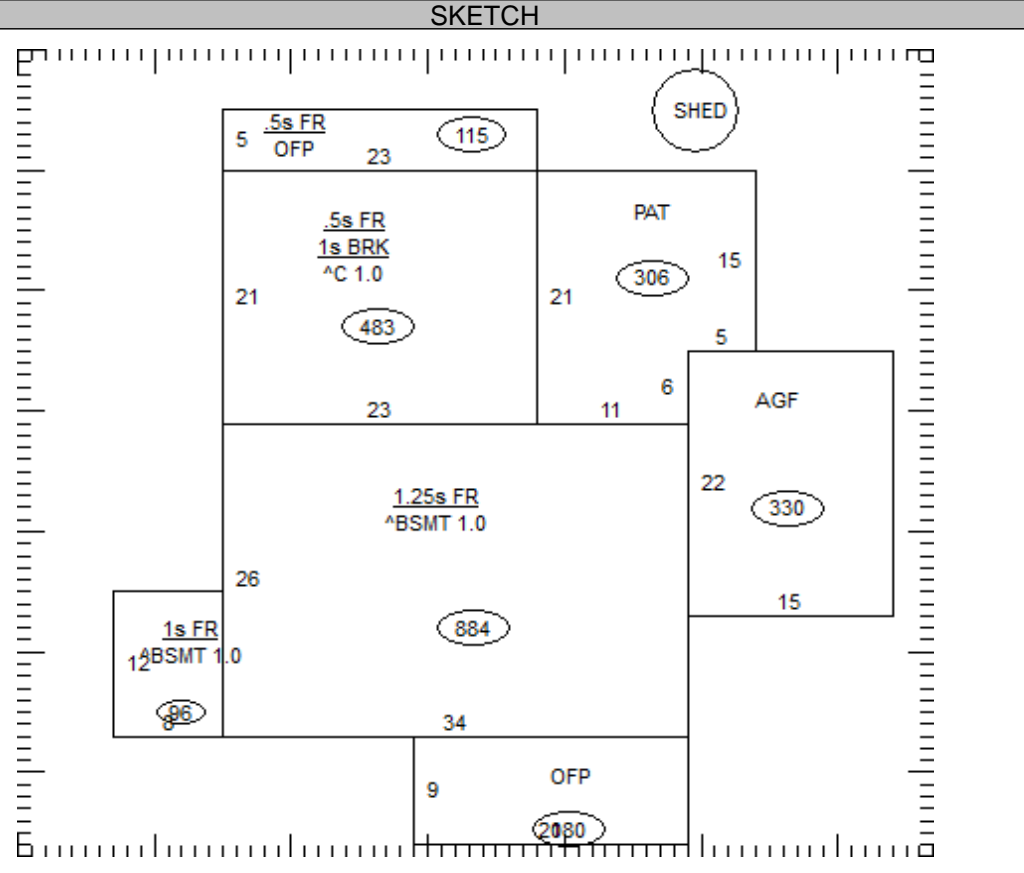

OCCUPANCY	ST.HT	SIZE	AREA	GRADE	PRICE	AGE	REMD	CND	UNADJ VAL	PHYS	PHYS VAL	FUNC	TRUE VAL
DWELLING	1.5	SK	1,983	C+		1950		A	312,600	45	171,930		197,700
1 Shed		12x16	192	C	9.90	2011		A	1,900	19	1,540		1,500
2													
3													
4													
5													
6													
7													
8													
9													
10													
11													

05-100300.0000	<b>TOTAL</b>	199,200
----------------	--------------	---------

**COMMENTS**

Dwelling has an Economic Factor of 115%