

BUTLER TWP-COLDWATER CORP / COLDWATER SD
08-28-454-011

Property Class: 510

Neighborhood
000506-TS50

Map: 14B10

Block:

Card: 13

Bk: Pg:

05-100100.0000

WUEBKER CARL JAMES

WUEBKER CARL JAMES
403 ELM ST
COLDWATER, OH 45828

LEGAL INFORMATION
SELHORST SECOND ADD

LOT#: 613

	OWNERSHIP	ADDRESS	CITY	STATE	ZIP	DATE	AMOUNT	DEED:CONV#	JS	VALID
1	WUEBKER CARL JAMES	403 ELM ST	COLDWATER	OH	45828	03/05/2021	162,000	WDC : 160	<input type="checkbox"/>	<input checked="" type="checkbox"/>
2	SUDHOFF KYLE C &	403 ELM ST	COLDWATER	OH	45828	06/03/2014	125,000	WDC : 324	<input type="checkbox"/>	<input checked="" type="checkbox"/>
3	STOLTZ JEFFREY J &	403 ELM ST	COLDWATER	OH	45828	05/03/2000	88,000	: A : 0	<input type="checkbox"/>	<input checked="" type="checkbox"/>

X: TTO LISTER: NS DATE: 01/25/2005 TIME: 12:00:00 AM LETTER LETTER REC'D GIS CODE

STREET/ROAD TOPOGRAPHY PU-UTILITIES-PR NEIGHBORHOOD INFLUENCE FACTORS PROPERTY LOCATION

PAVED LEVEL WATER IMPROVING A. NO ROAD F. RESTRICT 403 ELM ST, COLDWATER
 GRAVEL HIGH SEWER STATIC B. TOPGRHY G. WOOD LT
 DIRT LOW GAS DECLINING C. Ex Front H. VACANCY
 SIDEWALKS ROLLING ELECTRIC OLD D. QUANTITY I. WATER FRONT
 CURBS STANDARD STANDARD STANDARD E. SZ/SHAPE J. OTHER/CDU

PROPERTY LOCATION
403 ELM ST, COLDWATER

COMMENT

TY2022:Net Gen=\$1,795.90, Other
Assessment=\$0.00
DE09 PER DATA MAILER CORRECTED FIN
BASEMENT
DE16 DESKTOP REVIEW CHG: chg efp to ebz, cor
stry hgt, add stp

LAND COMPUTATIONS

LAND TYPE	SIZE	M	RATE	C	INF	M	VALUE	C
F:Front	F73 D122	ST440	DP90	ADJ396			28,900	0
					TOTAL		28,900	0

VALUATION SUMMARY

VALUE YEAR	2023	2020	2017				
REASON FOR CHANGE	RAPP	RAPP	RAPP				
APPRaised	LAND	28,900	20,500	17,100			
VALUE	IMPR	131,900	115,800	90,200			
	TOTAL	160,800	136,300	107,300			
ASSESSED	LAND	10,120	7,180	5,990			
VALUE	IMPR	46,170	40,530	31,570			
	TOTAL	56,290	47,710	37,560			

OCCUPANCY		EXTERIOR		FLOOR	AREA	CONST	VALUE
<input checked="" type="checkbox"/> SF	<input type="checkbox"/> DU	<input type="checkbox"/> TR	<input type="checkbox"/> WOOD	1	830	FR	140,130
<input type="checkbox"/> CONVERSION	<input type="checkbox"/> STUCCO			.25	130	FR	20,010
BUILDING TYPE	<input checked="" type="checkbox"/> ALM/VYNL			.5	155	FR	16,230
<input type="checkbox"/> MOBILE HOME	<input type="checkbox"/> CONC BLK						
<input type="checkbox"/> BI/TR LEVEL	<input type="checkbox"/> METAL						
<input type="checkbox"/> MOD/MAN	<input type="checkbox"/> BRICK						
<input type="checkbox"/>	<input type="checkbox"/> STONE						
ROOFING		ROOF TYPE					
<input type="checkbox"/> METAL	<input checked="" type="checkbox"/> GABLE						
<input type="checkbox"/> SLT/TLE	<input type="checkbox"/> HIP						
<input checked="" type="checkbox"/> SHINGLES	<input type="checkbox"/> GAMBREL						
<input type="checkbox"/> SHAKES	<input type="checkbox"/> MANSARD						
<input type="checkbox"/> COMPOSITE	<input type="checkbox"/> FLAT						
FLOORS		B	1	2	3	U	
CONCRETE	<input checked="" type="checkbox"/>	<input type="checkbox"/>	<input type="checkbox"/>	<input type="checkbox"/>	<input type="checkbox"/>	<input type="checkbox"/>	
WOOD	<input type="checkbox"/>	<input type="checkbox"/>	<input type="checkbox"/>	<input type="checkbox"/>	<input type="checkbox"/>	<input type="checkbox"/>	
TILE/COMPO	<input type="checkbox"/>	<input type="checkbox"/>	<input type="checkbox"/>	<input type="checkbox"/>	<input type="checkbox"/>	<input type="checkbox"/>	
CARPET	<input checked="" type="checkbox"/>	<input checked="" type="checkbox"/>	<input checked="" type="checkbox"/>	<input type="checkbox"/>	<input type="checkbox"/>	<input type="checkbox"/>	
INT. FINISH		B	1	2	3	U	
PLASTER/DW	<input type="checkbox"/>	<input checked="" type="checkbox"/>	<input checked="" type="checkbox"/>	<input type="checkbox"/>	<input type="checkbox"/>	<input type="checkbox"/>	
PANELING	<input checked="" type="checkbox"/>	<input type="checkbox"/>	<input type="checkbox"/>	<input type="checkbox"/>	<input type="checkbox"/>	<input type="checkbox"/>	
UNFINISHED	<input type="checkbox"/>	<input type="checkbox"/>	<input type="checkbox"/>	<input type="checkbox"/>	<input type="checkbox"/>	<input type="checkbox"/>	
ACCOMMODATIONS							
# OF ROOMS	1	4	2				
BEDROOMS		2	2				
FIREPLACES							
HEAT & AC		B	1	2	3	U	
NO HEAT	<input type="checkbox"/>	<input type="checkbox"/>	<input type="checkbox"/>	<input type="checkbox"/>	<input type="checkbox"/>	<input type="checkbox"/>	
CTRL HEAT	<input checked="" type="checkbox"/>	<input checked="" type="checkbox"/>	<input checked="" type="checkbox"/>	<input checked="" type="checkbox"/>	<input type="checkbox"/>	<input type="checkbox"/>	
HW/STEAM	<input type="checkbox"/>	<input type="checkbox"/>	<input type="checkbox"/>	<input type="checkbox"/>	<input type="checkbox"/>	<input type="checkbox"/>	
ELECTRIC	<input type="checkbox"/>	<input type="checkbox"/>	<input type="checkbox"/>	<input type="checkbox"/>	<input type="checkbox"/>	<input type="checkbox"/>	
HEAT PUMP	<input type="checkbox"/>	<input type="checkbox"/>	<input type="checkbox"/>	<input type="checkbox"/>	<input type="checkbox"/>	<input type="checkbox"/>	
FLR/WALL	<input type="checkbox"/>	<input type="checkbox"/>	<input type="checkbox"/>	<input type="checkbox"/>	<input type="checkbox"/>	<input type="checkbox"/>	
STVE/SPCE	<input type="checkbox"/>	<input type="checkbox"/>	<input type="checkbox"/>	<input type="checkbox"/>	<input type="checkbox"/>	<input type="checkbox"/>	
GEO THERMAL	<input type="checkbox"/>	<input type="checkbox"/>	<input type="checkbox"/>	<input type="checkbox"/>	<input type="checkbox"/>	<input type="checkbox"/>	
OUTSIDE	<input type="checkbox"/>	<input type="checkbox"/>	<input type="checkbox"/>	<input type="checkbox"/>	<input type="checkbox"/>	<input type="checkbox"/>	
CTRL A/C	<input checked="" type="checkbox"/>	<input checked="" type="checkbox"/>	<input checked="" type="checkbox"/>	<input checked="" type="checkbox"/>	<input type="checkbox"/>	<input type="checkbox"/>	
PLUMBING							BASE <input checked="" type="checkbox"/>
X FULL BATH							
X HALF BATH							
X FIXTURES	1						
BSMT		830					11,870
SUBTOTAL							188,240
MULTI-FAMILY #	0						0
BUILDING TYPE	100%						0
BSMT FINISH	415 S.F.						5,930
FIREPLACE #	0						0
HEATING	0 S.F.						0
AIR COND	1,530 S.F.						2,520
PLUMBING #	1						1,210
GARAGES & CARPORTS							7,600
EXTRA FEATURES							3,000
SUBTOTAL							208,500
GRADE FACTOR							100 %
UNADJUSTED VALUE							208,500
FACTOR							100 %

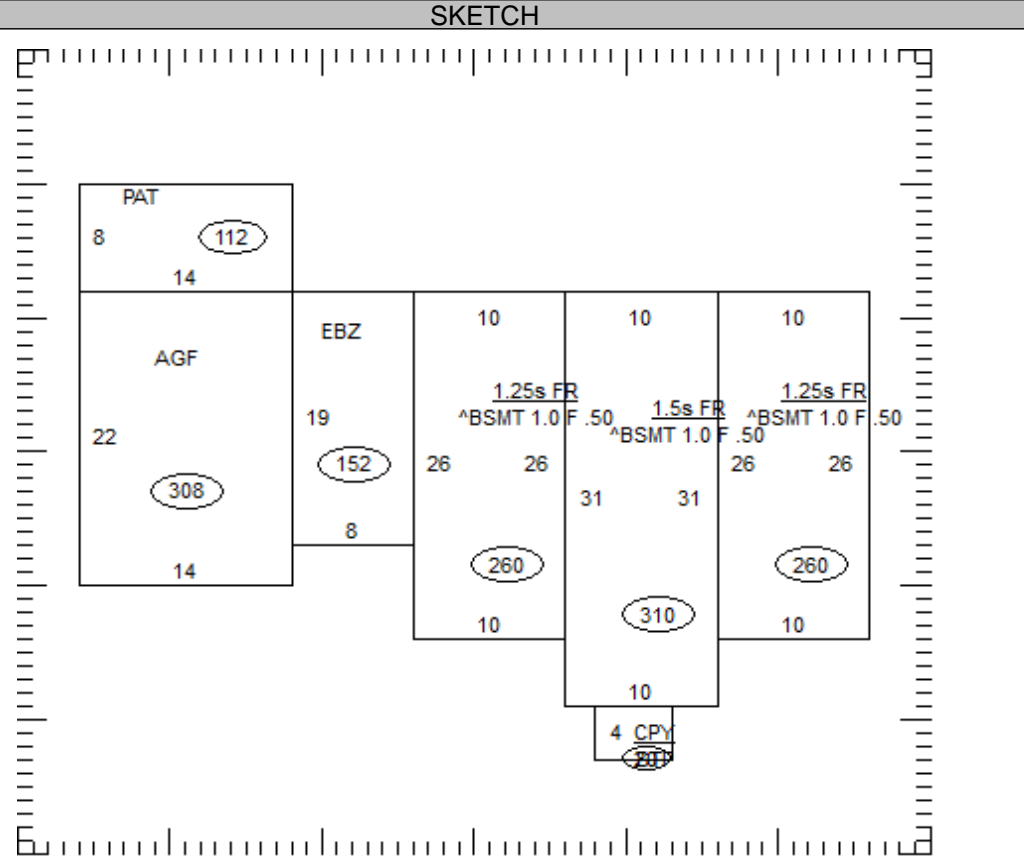

OCCUPANCY	ST.HT	SIZE	AREA	GRADE	PRICE	AGE	REMD	CND	UNADJ VAL	PHYS	PHYS VAL	FUNC	TRUE VAL
DWELLING	1.5	SK	1,115	C		1950		A	208,500	45	114,680		131,900
1													
2													
3													
4													
5													
6													
7													
8													
9													
10													
11													

05-100100.0000

TOTAL 131,900

COMMENTS

Dwelling has an Economic Factor of 115%