

OCCUPANCY	EXTERIOR	FLOOR	AREA	CONST	VALUE
<input checked="" type="checkbox"/> SF <input type="checkbox"/> DU <input type="checkbox"/> TR	<input type="checkbox"/> WOOD	1	994	FR	160,310
<input type="checkbox"/> CONVERSION	<input type="checkbox"/> STUCCO	.5	400	FR	40,000
BUILDING TYPE	<input checked="" type="checkbox"/> ALM/VYNL				
<input type="checkbox"/> MOBILE HOME	<input type="checkbox"/> CONC BLK				
<input type="checkbox"/> BI/TR LEVEL	<input type="checkbox"/> METAL				
<input type="checkbox"/> MOD/MAN	<input type="checkbox"/> BRICK				
<input type="checkbox"/>	<input type="checkbox"/> STONE				

ROOFING	ROOF TYPE
<input type="checkbox"/> METAL	<input checked="" type="checkbox"/> GABLE
<input type="checkbox"/> SLT/TLE	<input type="checkbox"/> HIP
<input checked="" type="checkbox"/> SHINGLES	<input type="checkbox"/> GAMBREL
<input type="checkbox"/> SHAKES	<input type="checkbox"/> MANSARD
<input type="checkbox"/> COMPOSITE	<input type="checkbox"/> FLAT

FLOORS	B	1	2	3	U
CONCRETE	<input checked="" type="checkbox"/>	<input type="checkbox"/>	<input type="checkbox"/>	<input type="checkbox"/>	<input type="checkbox"/>
WOOD	<input type="checkbox"/>	<input checked="" type="checkbox"/>	<input checked="" type="checkbox"/>	<input type="checkbox"/>	<input type="checkbox"/>
TILE/COMPO	<input type="checkbox"/>	<input type="checkbox"/>	<input type="checkbox"/>	<input type="checkbox"/>	<input type="checkbox"/>
CARPET	<input type="checkbox"/>	<input checked="" type="checkbox"/>	<input checked="" type="checkbox"/>	<input type="checkbox"/>	<input type="checkbox"/>
INT. FINISH	B	1	2	3	U
PLASTER/DW	<input type="checkbox"/>	<input checked="" type="checkbox"/>	<input checked="" type="checkbox"/>	<input type="checkbox"/>	<input type="checkbox"/>
PANELING	<input type="checkbox"/>	<input type="checkbox"/>	<input type="checkbox"/>	<input type="checkbox"/>	<input type="checkbox"/>
UNFINISHED	<input type="checkbox"/>	<input type="checkbox"/>	<input type="checkbox"/>	<input type="checkbox"/>	<input type="checkbox"/>
ACCOMMODATIONS					
# OF ROOMS		2	3		
BEDROOMS			3		
FIREPLACES		1			
HEAT & AC	B	1	2	3	U
NO HEAT	<input type="checkbox"/>	<input type="checkbox"/>	<input type="checkbox"/>	<input type="checkbox"/>	<input type="checkbox"/>
CTRL HEAT	<input type="checkbox"/>	<input checked="" type="checkbox"/>	<input checked="" type="checkbox"/>	<input type="checkbox"/>	<input type="checkbox"/>
HW/STEAM	<input type="checkbox"/>	<input type="checkbox"/>	<input type="checkbox"/>	<input type="checkbox"/>	<input type="checkbox"/>
ELECTRIC	<input type="checkbox"/>	<input type="checkbox"/>	<input type="checkbox"/>	<input type="checkbox"/>	<input type="checkbox"/>
HEAT PUMP	<input type="checkbox"/>	<input type="checkbox"/>	<input type="checkbox"/>	<input type="checkbox"/>	<input type="checkbox"/>
FLR/WALL	<input type="checkbox"/>	<input type="checkbox"/>	<input type="checkbox"/>	<input type="checkbox"/>	<input type="checkbox"/>
STVE/SPCE	<input type="checkbox"/>	<input type="checkbox"/>	<input type="checkbox"/>	<input type="checkbox"/>	<input type="checkbox"/>
GEO THERMAL	<input type="checkbox"/>	<input type="checkbox"/>	<input type="checkbox"/>	<input type="checkbox"/>	<input type="checkbox"/>
OUTSIDE	<input type="checkbox"/>	<input type="checkbox"/>	<input type="checkbox"/>	<input type="checkbox"/>	<input type="checkbox"/>
CTRL A/C	<input type="checkbox"/>	<input checked="" type="checkbox"/>	<input checked="" type="checkbox"/>	<input type="checkbox"/>	<input type="checkbox"/>
PLUMBING	BASE	<input checked="" type="checkbox"/>			
X FULL BATH					
X HALF BATH	1		1		
X FIXTURES					

BSMT	497		7,110
SUBTOTAL			207,420
MULTI-FAMILY #	0		0
BUILDING TYPE	100%		0
BSMT FINISH	0 S.F.		0
FIREPLACE #	1		4,400
HEATING	0 S.F.		0
AIR COND	1,394 S.F.		2,300
PLUMBING #	4		4,840
GARAGES & CARPORTS			0
EXTRA FEATURES			5,900
SUBTOTAL			224,860
GRADE FACTOR			100 %
UNADJUSTED VALUE			224,860
FACTOR			100 %

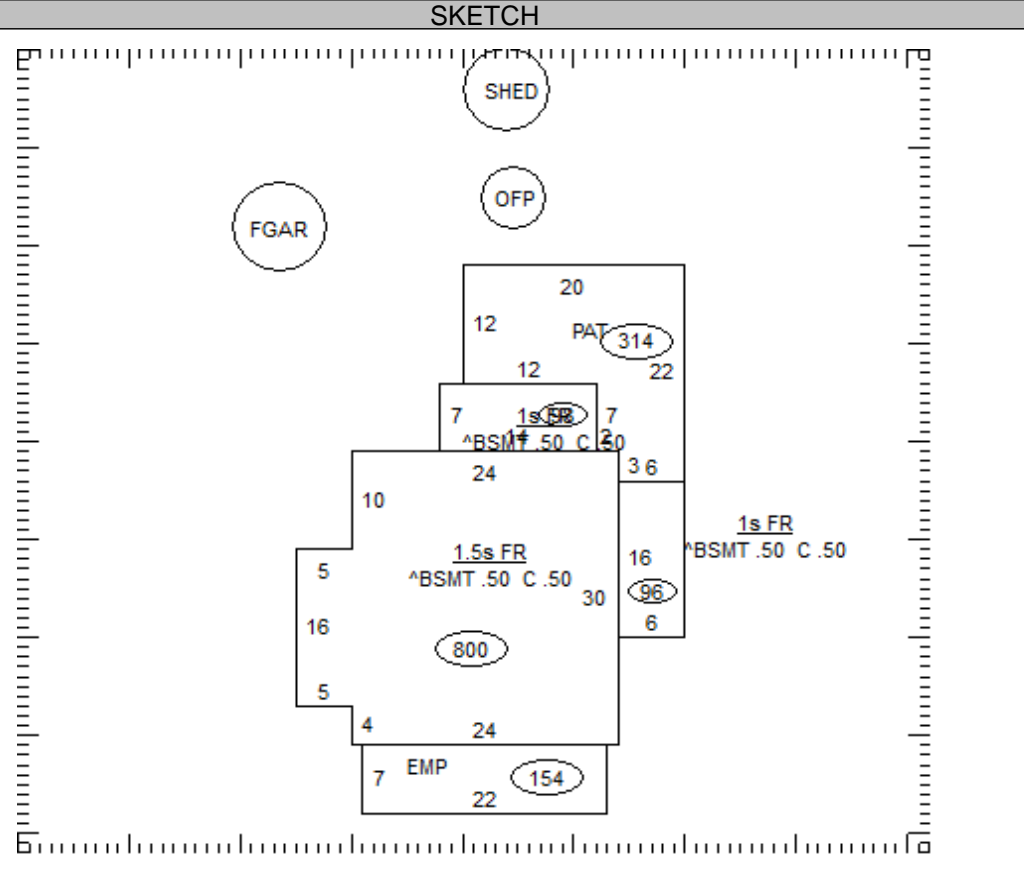

OCCUPANCY	ST.HT	SIZE	AREA	GRADE	PRICE	AGE	REMD	CND	UNADJ VAL	PHYS	PHYS VAL	FUNC	TRUE VAL
DWELLING	1.5	SK	1,394	C		1916	1999	A	224,860	28	161,900		165,100
1 Gar - Frame		16x20	320	D	18.96	1951		A	6,070	95	300		300
2 Shed		8x12	96	C		2000		A		37			0
3 OFF		4x12	48	C	16.04	2000		A	770	37	490		500
4													
5													
6													
7													
8													
9													
10													
11													

05-066500.0000 TOTAL 165,900

COMMENTS

Dwelling has an Economic Factor of 102% (Rollback Basis=\$184,000)