

BUTLER TWP-COLDWATER CORP / COLDWATER SD  
08-34-113-002

Property Class: 510  
Neighborhood  
000503-TM50  
Map: 14D1  
Block:  
Card: 55  
Bk: Pg:

05-065100.0000

**FORSTHOEFEL ROSS**  
FORSTHOEFEL ROSS  
407 E WALNUT ST  
COLDWATER, OH 45828

**LEGAL INFORMATION**  
FETZERS 2ND ADD  
  
LOT#: 274

OWNERSHIP	ADDRESS	CITY	STATE	ZIP	DATE	AMOUNT	DEED:CONV#	JS	VALID
1 FORSTHOEFEL ROSS	407 E WALNUT ST	COLDWATER	OH	45828	09/29/2020	147,500	WDC : 706	<input type="checkbox"/>	<input checked="" type="checkbox"/>
2 GARWOOD CODY J &	407 E WALNUT ST	COLDWATER	OH	45828	09/20/2018	125,000	WDC : 720	<input type="checkbox"/>	<input checked="" type="checkbox"/>
3 NIEKAMP KYLE T	407 WALNUT ST	COLDWATER	OH	45828	07/02/2008	53,000	WDC : A : 452	<input type="checkbox"/>	<input type="checkbox"/>

X:  TTO LISTER: CL DATE: 07/14/2004 TIME: 03:03:59 PM  LETTER  LETTER REC'D GIS CODE

STREET/ROAD	TOPOGRAPHY	PU-UTILITIES-PR	NEIGHBORHOOD	INFLUENCE FACTORS				PROPERTY LOCATION
<input checked="" type="checkbox"/> PAVED	<input type="checkbox"/> LEVEL	<input type="checkbox"/> WATER	<input type="checkbox"/> IMPROVING	<input type="checkbox"/> A. NO ROAD	<input type="checkbox"/> F. RESTRICT	407 E WALNUT ST, COLDWATER		
<input type="checkbox"/> GRAVEL	<input type="checkbox"/> HIGH	<input type="checkbox"/> SEWER	<input type="checkbox"/> STATIC	<input type="checkbox"/> B. TOPGRHY	<input type="checkbox"/> G. WOOD LT	COMMENT		
<input type="checkbox"/> DIRT	<input type="checkbox"/> LOW	<input type="checkbox"/> GAS	<input type="checkbox"/> DECLINING	<input type="checkbox"/> C. Ex Front	<input type="checkbox"/> H. VACANCY	TY2022:Net Gen=\$1,361.14, Other		
<input type="checkbox"/> SIDEWALKS	<input type="checkbox"/> ROLLING	<input type="checkbox"/> ELECTRIC	<input type="checkbox"/> OLD	<input type="checkbox"/> D. QUANTITY	<input type="checkbox"/> I. WATER FRONT	Assessment=\$0.00		
<input type="checkbox"/> CURBS	<input checked="" type="checkbox"/> STANDARD	<input checked="" type="checkbox"/> STANDARD	<input type="checkbox"/> STANDARD	<input type="checkbox"/> E. SZ/SHAPE	<input type="checkbox"/> J. OTHER/CDU	DE09 PER DATA MAILER ADDED AC		
LAND COMPUTATIONS								DE19 RMV OWN OCC; DIDN'T RET APP
LAND TYPE	SIZE	M	RATE	C	INF	M	VALUE	C
F:Front	F50 D138	ST395	DP95	ADJ375		18,800		0
					TOTAL	18,800		0

**VALUATION SUMMARY**

VALUE YEAR	2023	2020	2019	2017
REASON FOR CHANGE	RAPP	RAPP	MISC	RAPP
APPRAISED	18,800	11,900	9,500	9,500
VALUE	IMPR	109,700	91,400	77,800
	TOTAL	128,500	103,300	87,300
ASSESSSED	LAND	6,580	4,170	3,330
VALUE	IMPR	38,400	31,990	27,230
	TOTAL	44,980	36,160	30,560

OCCUPANCY	EXTERIOR	FLOOR	AREA	CONST	VALUE
<input checked="" type="checkbox"/> SF <input type="checkbox"/> DU <input type="checkbox"/> TR	<input checked="" type="checkbox"/> WOOD	1	832	FR	140,470
<input type="checkbox"/> CONVERSION	<input type="checkbox"/> STUCCO	.25	208	FR	32,020
<b>BUILDING TYPE</b>	<input checked="" type="checkbox"/> ALM/VYNL				
<input type="checkbox"/> MOBILE HOME	<input type="checkbox"/> CONC BLK				
<input type="checkbox"/> BI/TR LEVEL	<input type="checkbox"/> METAL				
<input type="checkbox"/> MOD/MAN	<input type="checkbox"/> BRICK				
<input type="checkbox"/>	<input type="checkbox"/> STONE				
<b>ROOFING</b>	<b>ROOF TYPE</b>				
<input type="checkbox"/> METAL	<input checked="" type="checkbox"/> GABLE				
<input type="checkbox"/> SLT/TLE	<input type="checkbox"/> HIP				
<input checked="" type="checkbox"/> SHINGLES	<input type="checkbox"/> GAMBREL				
<input type="checkbox"/> SHAKES	<input type="checkbox"/> MANSARD				
<input type="checkbox"/> COMPOSITE	<input type="checkbox"/> FLAT				
<b>FLOORS</b>	<b>B 1 2 3 U</b>	BSMT	624		8,920
CONCRETE	<input checked="" type="checkbox"/> <input type="checkbox"/> <input type="checkbox"/> <input type="checkbox"/> <input type="checkbox"/>	<b>SUBTOTAL</b>			181,410
WOOD	<input type="checkbox"/> <input checked="" type="checkbox"/> <input checked="" type="checkbox"/> <input type="checkbox"/> <input type="checkbox"/>	MULTI-FAMILY #	0		0
TILE/COMPO	<input type="checkbox"/> <input type="checkbox"/> <input type="checkbox"/> <input type="checkbox"/> <input type="checkbox"/>	BUILDING TYPE	100%		0
CARPET	<input type="checkbox"/> <input type="checkbox"/> <input type="checkbox"/> <input type="checkbox"/> <input type="checkbox"/>	BSMT FINISH	120 S.F.		1,720
<b>INT. FINISH</b>	<b>B 1 2 3 U</b>	FIREPLACE #	0		0
PLASTER/DW	<input type="checkbox"/> <input checked="" type="checkbox"/> <input checked="" type="checkbox"/> <input type="checkbox"/> <input type="checkbox"/>	HEATING	0 S.F.		0
PANELING	<input type="checkbox"/> <input type="checkbox"/> <input type="checkbox"/> <input type="checkbox"/> <input type="checkbox"/>	AIR COND	1,040 S.F.		1,710
UNFINISHED	<input type="checkbox"/> <input type="checkbox"/> <input type="checkbox"/> <input type="checkbox"/> <input type="checkbox"/>	PLUMBING #	0		0
<b>ACCOMMODATIONS</b>		GARAGES & CARPORTS			0
# OF ROOMS		EXTRA FEATURES			10,000
BEDROOMS		<b>SUBTOTAL</b>			194,840
FIREPLACES		GRADE FACTOR			95 %
HEAT & AC		<b>UNADJUSTED VALUE</b>			185,100
NO HEAT	<input type="checkbox"/> <input type="checkbox"/> <input type="checkbox"/> <input type="checkbox"/> <input type="checkbox"/>	FACTOR			100 %
CTRL HEAT	<input type="checkbox"/> <input checked="" type="checkbox"/> <input checked="" type="checkbox"/> <input type="checkbox"/> <input type="checkbox"/>	<b>OCCUPANCY</b>	<b>ST.HT</b>	<b>SIZE</b>	<b>AREA</b>
HW/STEAM	<input type="checkbox"/> <input type="checkbox"/> <input type="checkbox"/> <input type="checkbox"/> <input type="checkbox"/>	DWELLING	1.25	SK	1,040
ELECTRIC	<input type="checkbox"/> <input type="checkbox"/> <input type="checkbox"/> <input type="checkbox"/> <input type="checkbox"/>	1 Gar - Frame		16x24	384
HEAT PUMP	<input type="checkbox"/> <input type="checkbox"/> <input type="checkbox"/> <input type="checkbox"/> <input type="checkbox"/>	2			
FLR/WALL	<input type="checkbox"/> <input type="checkbox"/> <input type="checkbox"/> <input type="checkbox"/> <input type="checkbox"/>	3			
STVE/SPCE	<input type="checkbox"/> <input type="checkbox"/> <input type="checkbox"/> <input type="checkbox"/> <input type="checkbox"/>	4			
GEO THERMAL	<input type="checkbox"/> <input type="checkbox"/> <input type="checkbox"/> <input type="checkbox"/> <input type="checkbox"/>	5			
OUTSIDE	<input type="checkbox"/> <input type="checkbox"/> <input type="checkbox"/> <input type="checkbox"/> <input type="checkbox"/>	6			
CTRL A/C	<input type="checkbox"/> <input checked="" type="checkbox"/> <input checked="" type="checkbox"/> <input type="checkbox"/> <input type="checkbox"/>	7			
PLUMBING		8			
X FULL BATH		9			
X HALF BATH		10			
X FIXTURES		11			

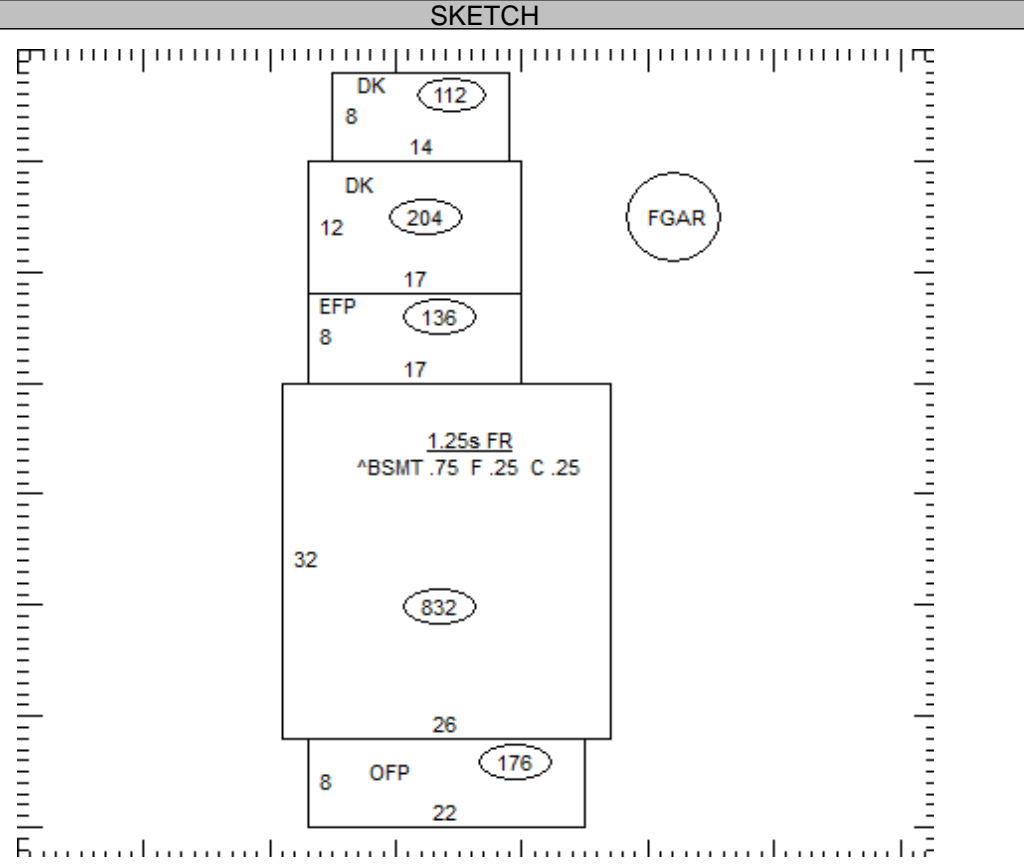

05-065100.0000

**TOTAL** 109,700

**COMMENTS**

Dwelling has an Economic Factor of 102%

Property Class: 510

Neighborhood  
000503-TM50

Map: 14D1

Block:

Card: 55

Bk: Pg:

BUTLER TWP-COLDWATER CORP / COLDWATER SD  
08-34-113-002

05-065100.0000

**FORSTHOEFEL ROSS**  
FORSTHOEFEL ROSS  
407 E WALNUT ST  
COLDWATER, OH 45828

**LEGAL INFORMATION**  
FETZERS 2ND ADD  
  
LOT#: 274

	OWNERSHIP	ADDRESS	CITY	STATE	ZIP	DATE	AMOUNT	DEED:CONV#	JS	VALID
1	ACE OF TRADES LLC	411 STACHLER DR PO BOX	SAINT HENRY	OH	45883	03/25/2008	69,000	WDC : A : 182	<input type="checkbox"/>	<input checked="" type="checkbox"/>
2	DEUTSCHE BANK NATIONAL	12650 INGENUITY DR	ORLANDO	FL	32826	10/02/2007	56,000	SHC : S : 706	<input type="checkbox"/>	<input checked="" type="checkbox"/>
3	GAGNON LISA	407 E WALNUT ST	COLDWATER	OH	45828	10/16/1998	58,000	: A : 0	<input type="checkbox"/>	<input checked="" type="checkbox"/>

X:  TTO LISTER: CL DATE: 07/14/2004 TIME: 03:03:59 PM  LETTER  LETTER REC'D GIS CODE

STREET/ROAD	TOPOGRAPHY	PU-UTILITIES-PR	NEIGHBORHOOD	INFLUENCE FACTORS	PROPERTY LOCATION
<input checked="" type="checkbox"/> PAVED	<input type="checkbox"/> LEVEL	<input type="checkbox"/> WATER <input type="checkbox"/>	<input type="checkbox"/> IMPROVING	<input type="checkbox"/> A. NO ROAD <input type="checkbox"/> F. RESTRICT	407 E WALNUT ST, COLDWATER <b>COMMENT</b>
<input type="checkbox"/> GRAVEL	<input type="checkbox"/> HIGH	<input type="checkbox"/> SEWER <input type="checkbox"/>	<input type="checkbox"/> STATIC	<input type="checkbox"/> B. TOPGRHY <input type="checkbox"/> G. WOOD LT	
<input type="checkbox"/> DIRT	<input type="checkbox"/> LOW	<input type="checkbox"/> GAS <input type="checkbox"/>	<input type="checkbox"/> DECLINING	<input type="checkbox"/> C. Ex Front <input type="checkbox"/> H. VACANCY	
<input type="checkbox"/> SIDEWALKS	<input type="checkbox"/> ROLLING	<input type="checkbox"/> ELECTRIC <input type="checkbox"/>	<input type="checkbox"/> OLD	<input type="checkbox"/> D. QUANTITY <input type="checkbox"/> I. WATER FRONT	
<input type="checkbox"/> CURBS	<input checked="" type="checkbox"/> STANDARD	<input checked="" type="checkbox"/> STANDARD	<input type="checkbox"/> STANDARD	<input type="checkbox"/> E. SZ/SHAPE <input type="checkbox"/> J. OTHER/CDU	

LAND COMPUTATIONS							
LAND TYPE	SIZE	M	RATE	C	INF	M	VALUE C
TOTAL						18,800	0

**VALUATION SUMMARY**

VALUE YEAR	REASON FOR CHANGE	APPRaised	IMPR	TOTAL	ASSESSED	IMPR	TOTAL

OCCUPANCY	EXTERIOR	FLOOR	AREA	CONST	VALUE
<input type="checkbox"/> SF <input type="checkbox"/> DU <input type="checkbox"/> TR	<input type="checkbox"/> WOOD				
<input type="checkbox"/> CONVERSION	<input type="checkbox"/> STUCCO				
<b>BUILDING TYPE</b>	<input type="checkbox"/> ALM/VYNL				
<input type="checkbox"/> MOBILE HOME	<input type="checkbox"/> CONC BLK				
<input type="checkbox"/> BI/TR LEVEL	<input type="checkbox"/> METAL				
<input type="checkbox"/> MOD/MAN	<input type="checkbox"/> BRICK				
<input type="checkbox"/>	<input type="checkbox"/> STONE				
ROOFING	ROOF TYPE				
<input type="checkbox"/> METAL	<input type="checkbox"/> GABLE				
<input type="checkbox"/> SLT/TLE	<input type="checkbox"/> HIP				
<input type="checkbox"/> SHINGLES	<input type="checkbox"/> GAMBREL				
<input type="checkbox"/> SHAKES	<input type="checkbox"/> MANSARD				
<input type="checkbox"/> COMPOSITE	<input type="checkbox"/> FLAT				

SUBTOTAL			0
MULTI-FAMILY #	0		0
BUILDING TYPE	000%		0
BSMT FINISH	0 S.F.		0
FIREPLACE #	0		0
HEATING	0 S.F.		0
AIR COND	0 S.F.		0
PLUMBING #	0		0
GARAGES & CARPORTS			0
EXTRA FEATURES			0
SUBTOTAL			0
GRADE FACTOR			%
UNADJUSTED VALUE			0
FACTOR			%

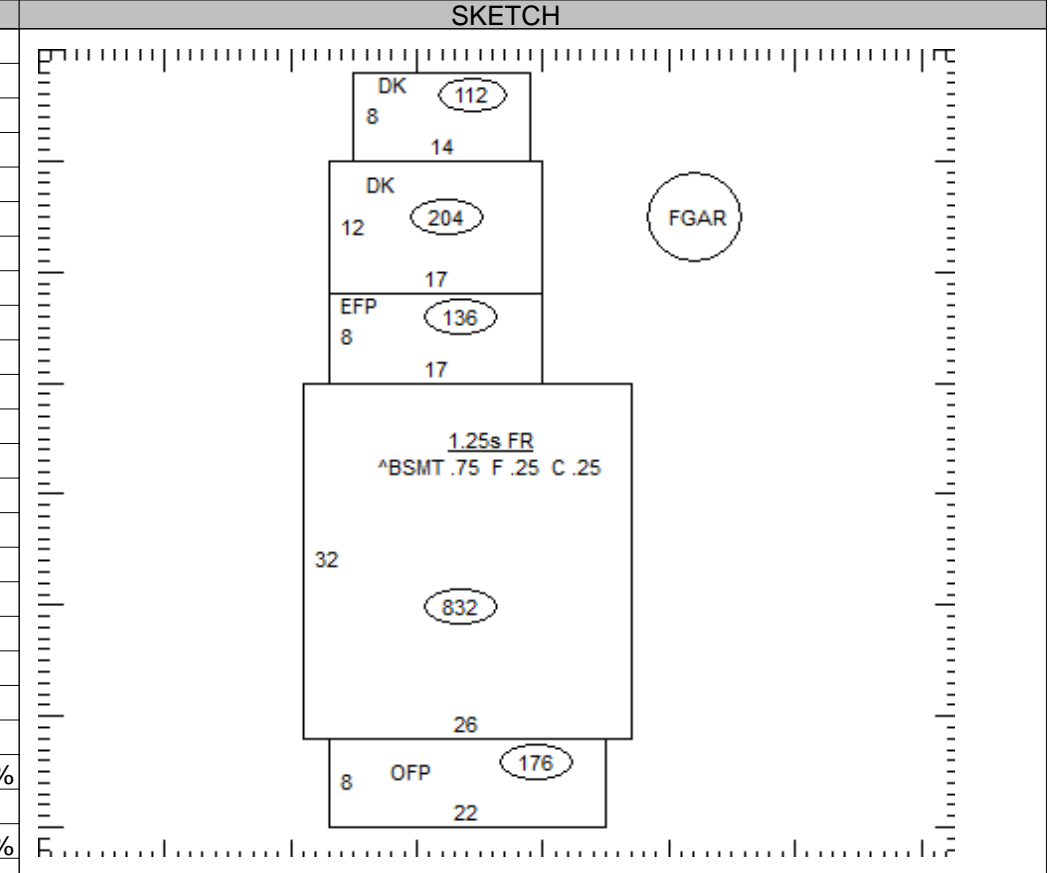

OCCUPANCY	ST.HT	SIZE	AREA	GRADE	PRICE	AGE	REMD	CND	UNADJ VAL	PHYS	PHYS VAL	FUNC	TRUE VAL
DWELLING		SK											
1													
2													
3													
4													
5													
6													
7													
8													
9													
10													
11													

05-065100.0000 TOTAL 0

COMMENTS