

BUTLER TWP-COLDWATER CORP / COLDWATER SD
08-27-378-006

Property Class: 510
Neighborhood
000502-TM50

Map: 14A6
Block:
Card: 100

Bk: Pg:

05-062000.0000

LEGAL INFORMATION
FETZER ADD
LOT 244 & W SD LOT 243
LOT#: 244

DANIELS MICHAEL & BRUNSWICK AMBER
DANIELS MICHAEL & BRUNSWICK AMBER
508 E NORTH ST
COLDWATER, OH 45828

OWNERSHIP	ADDRESS	CITY	STATE	ZIP	DATE	AMOUNT	DEED:CONV#	JS	VALID
1 DANIELS MICHAEL &	508 E NORTH ST	COLDWATER	OH	45828	07/24/2018	63,400	WDC : 544	<input type="checkbox"/>	<input checked="" type="checkbox"/>
2 FELLA ANTHONY L & SUSAN K	508 E NORTH ST	COLDWATER	OH	45828	03/11/1988	38,000	: A : 0	<input type="checkbox"/>	<input checked="" type="checkbox"/>
3						0	0	<input type="checkbox"/>	<input type="checkbox"/>

X: TTO LISTER: DA DATE: 03/14/2005 TIME: 12:00:00 AM LETTER LETTER REC'D GIS CODE

STREET/ROAD TOPOGRAPHY PU-UTILITIES-PR NEIGHBORHOOD INFLUENCE FACTORS PROPERTY LOCATION

PAVED LEVEL WATER IMPROVING A. NO ROAD F. RESTRICT 508 E NORTH ST, COLDWATER
 GRAVEL HIGH SEWER STATIC B. TOPGRHY G. WOOD LT COMMENT
 DIRT LOW GAS DECLINING C. Ex Front H. VACANCY TY2022:Net Gen=\$1,186.94, Other
 SIDEWALKS ROLLING ELECTRIC OLD D. QUANTITY I. WATER FRONT Assessment=\$0.00
 CURBS STANDARD STANDARD E. SZ/SHAPE J. OTHER/CDU DE16 COR FL MISMATCH
 DE16 DESKTOP REVIEW CHG:cor can/pat
 msmnts

LAND COMPUTATIONS

LAND TYPE	SIZE	M	RATE	C	INF	M	VALUE	C
F:Front	F72 D132	ST350	DP94	ADJ329		23,700	0	
TOTAL						23,700	0	

VALUATION SUMMARY

VALUE YEAR	2023	2020	2017					
REASON FOR CHANGE	RAPP	RAPP	RAPP					
APPRAISED	LAND	23,700	17,800	13,500				
VALUE	IMPR	89,900	74,500	61,100				
	TOTAL	113,600	92,300	74,600				
	ASSESSED	LAND	8,300	6,230	4,730			
VALUE	IMPR	31,470	26,080	21,390				
	TOTAL	39,770	32,310	26,120				

OCCUPANCY	EXTERIOR	FLOOR	AREA	CONST	VALUE												
<input checked="" type="checkbox"/> SF <input type="checkbox"/> DU <input type="checkbox"/> TR	<input type="checkbox"/> WOOD	1	684	FR	119,880												
<input type="checkbox"/> CONVERSION	<input type="checkbox"/> STUCCO	.25	122	FR	19,500												
BUILDING TYPE	<input checked="" type="checkbox"/> ALM/VYNL																
<input type="checkbox"/> MOBILE HOME	<input type="checkbox"/> CONC BLK																
<input type="checkbox"/> BI/TR LEVEL	<input type="checkbox"/> METAL																
<input type="checkbox"/> MOD/MAN	<input type="checkbox"/> BRICK																
<input type="checkbox"/>	<input type="checkbox"/> STONE																
ROOFING	ROOF TYPE																
<input type="checkbox"/> METAL	<input checked="" type="checkbox"/> GABLE																
<input type="checkbox"/> SLT/TLE	<input type="checkbox"/> HIP																
<input checked="" type="checkbox"/> SHINGLES	<input type="checkbox"/> GAMBREL																
<input type="checkbox"/> SHAKES	<input type="checkbox"/> MANSARD																
<input type="checkbox"/> COMPOSITE	<input type="checkbox"/> FLAT																
FLOORS	B 1 2 3 U	BSMT	366		5,230												
CONCRETE	<input checked="" type="checkbox"/> <input type="checkbox"/> <input type="checkbox"/> <input type="checkbox"/> <input type="checkbox"/>	SUBTOTAL			144,610												
WOOD	<input type="checkbox"/> <input checked="" type="checkbox"/> <input checked="" type="checkbox"/> <input type="checkbox"/> <input type="checkbox"/>	MULTI-FAMILY #	0		0												
TILE/COMPO	<input type="checkbox"/> <input type="checkbox"/> <input type="checkbox"/> <input type="checkbox"/> <input type="checkbox"/>	BUILDING TYPE	100%		0												
CARPET	<input type="checkbox"/> <input type="checkbox"/> <input type="checkbox"/> <input type="checkbox"/> <input type="checkbox"/>	BSMT FINISH	0 S.F.		0												
INT. FINISH	B 1 2 3 U	FIREPLACE #	0		0												
PLASTER/DW	<input type="checkbox"/> <input checked="" type="checkbox"/> <input checked="" type="checkbox"/> <input type="checkbox"/> <input type="checkbox"/>	HEATING	0 S.F.		0												
PANELING	<input type="checkbox"/> <input type="checkbox"/> <input type="checkbox"/> <input type="checkbox"/> <input type="checkbox"/>	AIR COND	806 S.F.		1,330												
UNFINISHED	<input checked="" type="checkbox"/> <input type="checkbox"/> <input type="checkbox"/> <input type="checkbox"/> <input type="checkbox"/>	PLUMBING #	0		0												
ACCOMMODATIONS		GARAGES & CARPORTS			0												
# OF ROOMS		EXTRA FEATURES			16,300												
BEDROOMS	4 3	SUBTOTAL			162,240												
FIREPLACES	1 3	GRADE FACTOR			100 %												
HEAT & AC	B 1 2 3 U	UNADJUSTED VALUE			162,240												
NO HEAT	<input type="checkbox"/> <input type="checkbox"/> <input type="checkbox"/> <input type="checkbox"/> <input type="checkbox"/>	FACTOR			100 %												
CTRL HEAT	<input type="checkbox"/> <input checked="" type="checkbox"/> <input checked="" type="checkbox"/> <input type="checkbox"/> <input type="checkbox"/>	OCCUPANCY ST.HT SIZE AREA GRADE PRICE AGE REMD CND UNADJ VAL PHYS PHYS VAL FUNC TRUE VAL															
HW/STEAM	<input type="checkbox"/> <input type="checkbox"/> <input type="checkbox"/> <input type="checkbox"/> <input type="checkbox"/>	DWELLING	1.25	SK	806	C				1942		A	162,240	45	89,230		89,200
ELECTRIC	<input type="checkbox"/> <input type="checkbox"/> <input type="checkbox"/> <input type="checkbox"/> <input type="checkbox"/>	1 Gar - Frame	8	24x24	576	C	23.70	1945				A	13,650	95	680		700
HEAT PUMP	<input type="checkbox"/> <input type="checkbox"/> <input type="checkbox"/> <input type="checkbox"/> <input type="checkbox"/>	2 Shed		10x10	100	C		2000				A		37			0
FLR/WALL	<input type="checkbox"/> <input type="checkbox"/> <input type="checkbox"/> <input type="checkbox"/> <input type="checkbox"/>	3															
STVE/SPCE	<input type="checkbox"/> <input type="checkbox"/> <input type="checkbox"/> <input type="checkbox"/> <input type="checkbox"/>	4															
GEO THERMAL	<input type="checkbox"/> <input type="checkbox"/> <input type="checkbox"/> <input type="checkbox"/> <input type="checkbox"/>	5															
OUTSIDE	<input type="checkbox"/> <input type="checkbox"/> <input type="checkbox"/> <input type="checkbox"/> <input type="checkbox"/>	6															
CTRL A/C	<input type="checkbox"/> <input checked="" type="checkbox"/> <input checked="" type="checkbox"/> <input type="checkbox"/> <input type="checkbox"/>	7															
PLUMBING		8															
X FULL BATH		9															
X HALF BATH		10															
X FIXTURES		11															

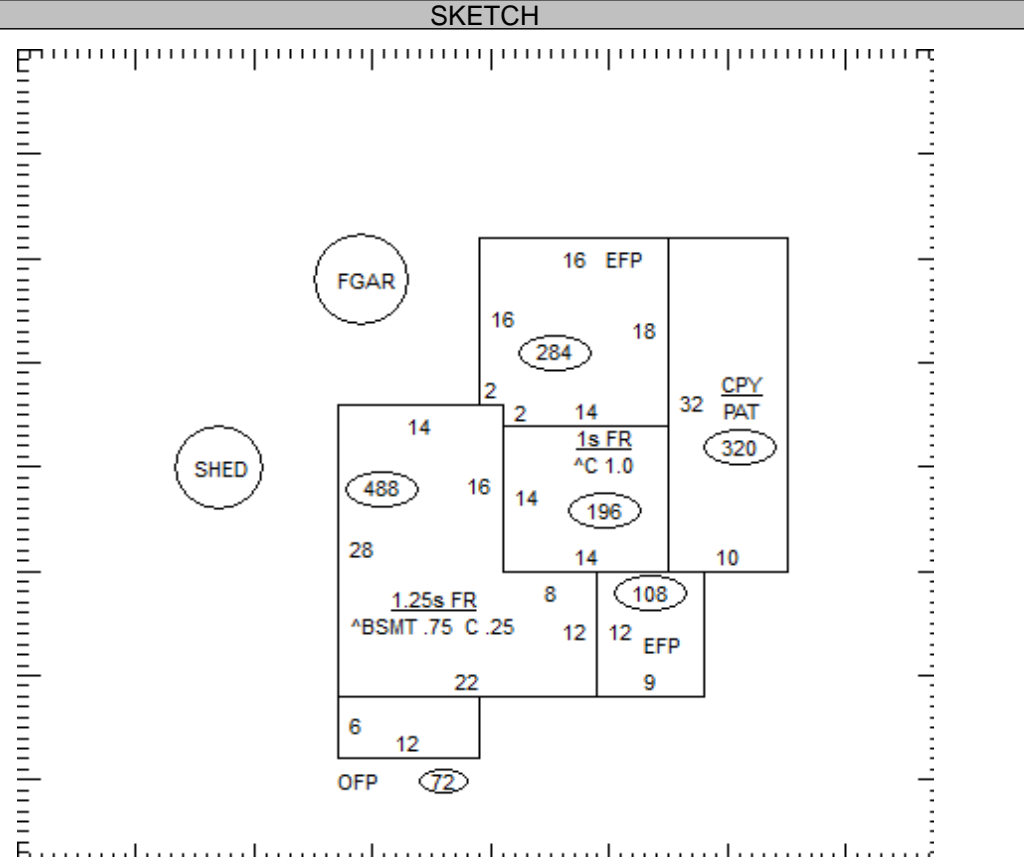

05-062000.0000

TOTAL 89,900

COMMENTS

Dwelling has an Economic Factor of 100%