

OCCUPANCY		EXTERIOR	
<input checked="" type="checkbox"/> SF	<input type="checkbox"/> DU	<input type="checkbox"/> WOOD	<input type="checkbox"/> TR
<input type="checkbox"/> CONVERSION		<input type="checkbox"/> STUCCO	
BUILDING TYPE		<input type="checkbox"/> ALM/VYNL	
<input type="checkbox"/> MOBILE HOME		<input type="checkbox"/> CONC BLK	
<input type="checkbox"/> BI/TR LEVEL		<input type="checkbox"/> METAL	
<input type="checkbox"/> MOD/MAN		<input checked="" type="checkbox"/> BRICK	
<input type="checkbox"/>		<input type="checkbox"/> STONE	

ROOFING		ROOF TYPE	
<input type="checkbox"/> METAL		<input type="checkbox"/> GABLE	
<input type="checkbox"/> SLT/TLE		<input checked="" type="checkbox"/> HIP	
<input checked="" type="checkbox"/> SHINGLES		<input type="checkbox"/> GAMBREL	
<input type="checkbox"/> SHAKES		<input type="checkbox"/> MANSARD	
<input type="checkbox"/> COMPOSITE		<input type="checkbox"/> FLAT	

FLOORS		B	1	2	3	U
CONCRETE	<input checked="" type="checkbox"/>	<input type="checkbox"/>	<input type="checkbox"/>	<input type="checkbox"/>	<input type="checkbox"/>	<input type="checkbox"/>
WOOD	<input type="checkbox"/>	<input checked="" type="checkbox"/>	<input checked="" type="checkbox"/>	<input type="checkbox"/>	<input type="checkbox"/>	<input type="checkbox"/>
TILE/COMPO	<input type="checkbox"/>	<input type="checkbox"/>	<input type="checkbox"/>	<input type="checkbox"/>	<input type="checkbox"/>	<input type="checkbox"/>
CARPET	<input type="checkbox"/>	<input checked="" type="checkbox"/>	<input type="checkbox"/>	<input type="checkbox"/>	<input type="checkbox"/>	<input type="checkbox"/>

INT. FINISH		B	1	2	3	U
PLASTER/DW	<input type="checkbox"/>	<input checked="" type="checkbox"/>	<input checked="" type="checkbox"/>	<input type="checkbox"/>	<input type="checkbox"/>	<input type="checkbox"/>
PANELING	<input type="checkbox"/>	<input type="checkbox"/>	<input type="checkbox"/>	<input type="checkbox"/>	<input type="checkbox"/>	<input type="checkbox"/>
UNFINISHED	<input type="checkbox"/>	<input type="checkbox"/>	<input type="checkbox"/>	<input type="checkbox"/>	<input type="checkbox"/>	<input type="checkbox"/>

ACCOMMODATIONS	
# OF ROOMS	2 4 3
BEDROOMS	3
FIREPLACES	1

HEAT & AC		B	1	2	3	U
NO HEAT	<input type="checkbox"/>	<input type="checkbox"/>	<input type="checkbox"/>	<input type="checkbox"/>	<input type="checkbox"/>	<input type="checkbox"/>
CTRL HEAT	<input checked="" type="checkbox"/>	<input checked="" type="checkbox"/>	<input checked="" type="checkbox"/>	<input type="checkbox"/>	<input type="checkbox"/>	<input type="checkbox"/>
HW/STEAM	<input type="checkbox"/>	<input type="checkbox"/>	<input type="checkbox"/>	<input type="checkbox"/>	<input type="checkbox"/>	<input type="checkbox"/>
ELECTRIC	<input type="checkbox"/>	<input type="checkbox"/>	<input type="checkbox"/>	<input type="checkbox"/>	<input type="checkbox"/>	<input type="checkbox"/>
HEAT PUMP	<input type="checkbox"/>	<input type="checkbox"/>	<input type="checkbox"/>	<input type="checkbox"/>	<input type="checkbox"/>	<input type="checkbox"/>
FLR/WALL	<input type="checkbox"/>	<input type="checkbox"/>	<input type="checkbox"/>	<input type="checkbox"/>	<input type="checkbox"/>	<input type="checkbox"/>
STVE/SPCE	<input type="checkbox"/>	<input type="checkbox"/>	<input type="checkbox"/>	<input type="checkbox"/>	<input type="checkbox"/>	<input type="checkbox"/>
GEOTHERMAL	<input type="checkbox"/>	<input type="checkbox"/>	<input type="checkbox"/>	<input type="checkbox"/>	<input type="checkbox"/>	<input type="checkbox"/>
OUTSIDE	<input type="checkbox"/>	<input type="checkbox"/>	<input type="checkbox"/>	<input type="checkbox"/>	<input type="checkbox"/>	<input type="checkbox"/>
CTRL A/C	<input checked="" type="checkbox"/>	<input checked="" type="checkbox"/>	<input checked="" type="checkbox"/>	<input type="checkbox"/>	<input type="checkbox"/>	<input type="checkbox"/>

PLUMBING		BASE	
X FULL BATH		1	
X HALF BATH	1		
X FIXTURES			

FLOOR	AREA	CONST	VALUE
1	1036	BRK	175,860
2ND	1036	BRK	84,410
BSMT	1036		14,810
SUBTOTAL			275,080
MULTI-FAMILY #	0		0
BUILDING TYPE	100%		0
BSMT FINISH	518 S.F.		7,410
FIREPLACE #	1		4,400
HEATING	0 S.F.		0
AIR COND	2,590 S.F.		4,270
PLUMBING #	5		6,050
GARAGES & CARPORTS			7,600
EXTRA FEATURES			8,500
SUBTOTAL			313,310
GRADE FACTOR			105 %
UNADJUSTED VALUE			328,980
FACTOR			100 %

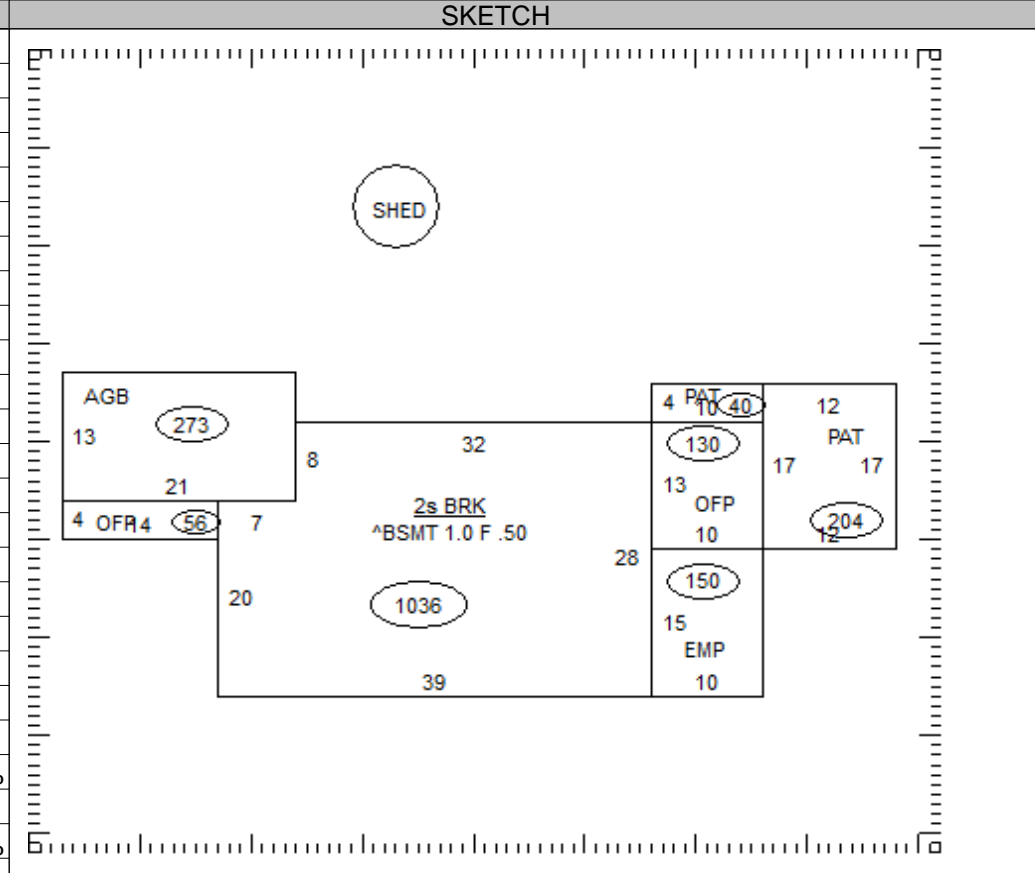

OCCUPANCY	ST.HT	SIZE	AREA	GRADE	PRICE	AGE	REMD	CND	UNADJ VAL	PHYS	PHYS VAL	FUNC	TRUE VAL
DWELLING	2	SK	2,072	C+		1940		A	328,980	45	180,940		208,100
1 Shed	PP	12x12	144	C		1990		A		57			0
2													
3													
4													
5													
6													
7													
8													
9													
10													
11													

05-035700.0000 TOTAL 208,100

COMMENTS

Dwelling has an Economic Factor of 115%