

BUTLER TWP-COLDWATER CORP / COLDWATER SD
08-34-127-009

Property Class: 510

Neighborhood
000503-TM50

Map: 14D4

Block:

Card: 16

Bk: Pg:

05-027900.0000

LOCHTEFELD MICHELLE A

LOCHTEFELD MICHELLE A

601 E WALNUT ST

COLDWATER, OH 45828

LEGAL INFORMATION

OUT LOT 31 S PT

RTS: 002-06-34 LOT#: 31

	OWNERSHIP	ADDRESS	CITY	STATE	ZIP	DATE	AMOUNT	DEED:CONV#	JS	VALID
1	LOCHTEFELD MICHELLE A	601 E WALNUT ST	COLDWATER	OH	45828	04/26/2013	90,000	WDC : 227	<input type="checkbox"/>	<input checked="" type="checkbox"/>
2	BIHN SETH E & GRIESHOP	606 E WALNUT ST	COLDWATER	OH	45828	02/09/2010	77,000	WDC : A : 75	<input type="checkbox"/>	<input type="checkbox"/>
3	STINEBAUGH TONY S	403 DEFIANCE ST	WAPAKONETA	OH	45895	07/16/2003	90,350	: A : 0	<input type="checkbox"/>	<input checked="" type="checkbox"/>

X: TTO LISTER: NS DATE: 02/10/2005 TIME: 12:00:00 AM LETTER LETTER REC'D GIS CODE

STREET/ROAD	TOPOGRAPHY	PU-UTILITIES-PR	NEIGHBORHOOD	INFLUENCE FACTORS	PROPERTY LOCATION
<input checked="" type="checkbox"/> PAVED	<input checked="" type="checkbox"/> LEVEL	<input type="checkbox"/> WATER <input type="checkbox"/>	<input type="checkbox"/> IMPROVING	<input type="checkbox"/> A. NO ROAD <input type="checkbox"/> F. RESTRICT	606 E WALNUT ST, COLDWATER
<input type="checkbox"/> GRAVEL	<input type="checkbox"/> HIGH	<input type="checkbox"/> SEWER <input type="checkbox"/>	<input checked="" type="checkbox"/> STATIC	<input type="checkbox"/> B. TOPGRHY <input type="checkbox"/> G. WOOD LT	COMMENT
<input type="checkbox"/> DIRT	<input type="checkbox"/> LOW	<input type="checkbox"/> GAS <input type="checkbox"/>	<input type="checkbox"/> DECLINING	<input type="checkbox"/> C. Ex Front <input type="checkbox"/> H. VACANCY	TY2022:Net Gen=\$1,647.24, Other
<input checked="" type="checkbox"/> SIDEWALKS	<input type="checkbox"/> ROLLING	<input type="checkbox"/> ELECTRIC <input type="checkbox"/>	<input type="checkbox"/> OLD	<input type="checkbox"/> D. QUANTITY <input type="checkbox"/> I. WATER FRONT	Assessment=\$0.00
<input type="checkbox"/> CURBS	<input type="checkbox"/> STANDARD	<input checked="" type="checkbox"/> STANDARD	<input type="checkbox"/> STANDARD	<input type="checkbox"/> E. SZ/SHAPE <input type="checkbox"/> J. OTHER/CDU	DE09 PER DATA MAILER CORRECTED PLMG

LAND COMPUTATIONS

LAND TYPE	SIZE	M	RATE	C	INF	M	VALUE	C
F:Front	F113 D50	ST395	DP57	ADJ225		25,400		0
					TOTAL	25,400		0

VALUATION SUMMARY

VALUE YEAR	2023	2020	2017				
REASON FOR CHANGE	RAPP	RAPP	RAPP				
APPRAISED	25,400	16,000	12,900				
VALUE	IMPR	130,800	112,100	97,000			
	TOTAL	156,200	128,100	109,900			
ASSESSED	LAND	8,890	5,600	4,520			
VALUE	IMPR	45,780	39,240	33,950			
	TOTAL	54,670	44,840	38,470			

OCCUPANCY	EXTERIOR	FLOOR	AREA	CONST	VALUE
<input checked="" type="checkbox"/> SF <input type="checkbox"/> DU <input type="checkbox"/> TR	<input checked="" type="checkbox"/> WOOD	1	768	BRK	132,530
<input type="checkbox"/> CONVERSION	<input type="checkbox"/> STUCCO	1	216	FR	34,840
BUILDING TYPE	<input type="checkbox"/> ALM/VYNL	.25	192	BRK	30,220
<input type="checkbox"/> MOBILE HOME	<input type="checkbox"/> CONC BLK				
<input type="checkbox"/> BI/TR LEVEL	<input type="checkbox"/> METAL				
<input type="checkbox"/> MOD/MAN	<input checked="" type="checkbox"/> BRICK				
<input type="checkbox"/> _____	<input type="checkbox"/> STONE				

ROOFING	ROOF TYPE
<input type="checkbox"/> METAL	<input checked="" type="checkbox"/> GABLE
<input type="checkbox"/> SLT/TLE	<input type="checkbox"/> HIP
<input checked="" type="checkbox"/> SHINGLES	<input type="checkbox"/> GAMBREL
<input type="checkbox"/> SHAKES	<input type="checkbox"/> MANSARD
<input type="checkbox"/> COMPOSITE	<input type="checkbox"/> FLAT

FLOORS	B	1	2	3	U
CONCRETE	<input checked="" type="checkbox"/>	<input type="checkbox"/>	<input type="checkbox"/>	<input type="checkbox"/>	<input type="checkbox"/>
WOOD	<input type="checkbox"/>	<input checked="" type="checkbox"/>	<input checked="" type="checkbox"/>	<input checked="" type="checkbox"/>	<input type="checkbox"/>
TILE/COMPO	<input type="checkbox"/>	<input type="checkbox"/>	<input type="checkbox"/>	<input type="checkbox"/>	<input type="checkbox"/>
CARPET	<input type="checkbox"/>	<input checked="" type="checkbox"/>	<input checked="" type="checkbox"/>	<input checked="" type="checkbox"/>	<input type="checkbox"/>
INT. FINISH	B	1	2	3	U
PLASTER/DW	<input type="checkbox"/>	<input checked="" type="checkbox"/>	<input checked="" type="checkbox"/>	<input checked="" type="checkbox"/>	<input type="checkbox"/>
PANELING	<input type="checkbox"/>	<input type="checkbox"/>	<input type="checkbox"/>	<input type="checkbox"/>	<input type="checkbox"/>
UNFINISHED	<input type="checkbox"/>	<input type="checkbox"/>	<input type="checkbox"/>	<input type="checkbox"/>	<input type="checkbox"/>
ACCOMMODATIONS					
# OF ROOMS	2	4		2	
BEDROOMS				2	
FIREPLACES		1			
HEAT & AC	B	1	2	3	U
NO HEAT	<input type="checkbox"/>	<input type="checkbox"/>	<input type="checkbox"/>	<input type="checkbox"/>	<input type="checkbox"/>
CTRL HEAT	<input checked="" type="checkbox"/>	<input checked="" type="checkbox"/>	<input checked="" type="checkbox"/>	<input checked="" type="checkbox"/>	<input type="checkbox"/>
HW/STEAM	<input type="checkbox"/>	<input type="checkbox"/>	<input type="checkbox"/>	<input type="checkbox"/>	<input type="checkbox"/>
ELECTRIC	<input type="checkbox"/>	<input type="checkbox"/>	<input type="checkbox"/>	<input type="checkbox"/>	<input type="checkbox"/>
HEAT PUMP	<input type="checkbox"/>	<input type="checkbox"/>	<input type="checkbox"/>	<input type="checkbox"/>	<input type="checkbox"/>
FLR/WALL	<input type="checkbox"/>	<input type="checkbox"/>	<input type="checkbox"/>	<input type="checkbox"/>	<input type="checkbox"/>
STVE/SPCE	<input type="checkbox"/>	<input type="checkbox"/>	<input type="checkbox"/>	<input type="checkbox"/>	<input type="checkbox"/>
GEO THERMAL	<input type="checkbox"/>	<input type="checkbox"/>	<input type="checkbox"/>	<input type="checkbox"/>	<input type="checkbox"/>
OUTSIDE	<input type="checkbox"/>	<input type="checkbox"/>	<input type="checkbox"/>	<input type="checkbox"/>	<input type="checkbox"/>
CTRL A/C	<input checked="" type="checkbox"/>	<input checked="" type="checkbox"/>	<input checked="" type="checkbox"/>	<input checked="" type="checkbox"/>	<input type="checkbox"/>
PLUMBING					
X FULL BATH			1		
X HALF BATH					
X FIXTURES					

BSMT	768		10,980
SUBTOTAL			208,570
MULTI-FAMILY #	0		0
BUILDING TYPE	100%		0
BSMT FINISH	330 S.F.		4,720
FIREPLACE #	1		4,400
HEATING	0 S.F.		0
AIR COND	1,506 S.F.		2,490
PLUMBING #	3		3,630
GARAGES & CARPORTS			8,600
EXTRA FEATURES			800
SUBTOTAL			233,210
GRADE FACTOR			100 %
UNADJUSTED VALUE			233,210
FACTOR			100 %

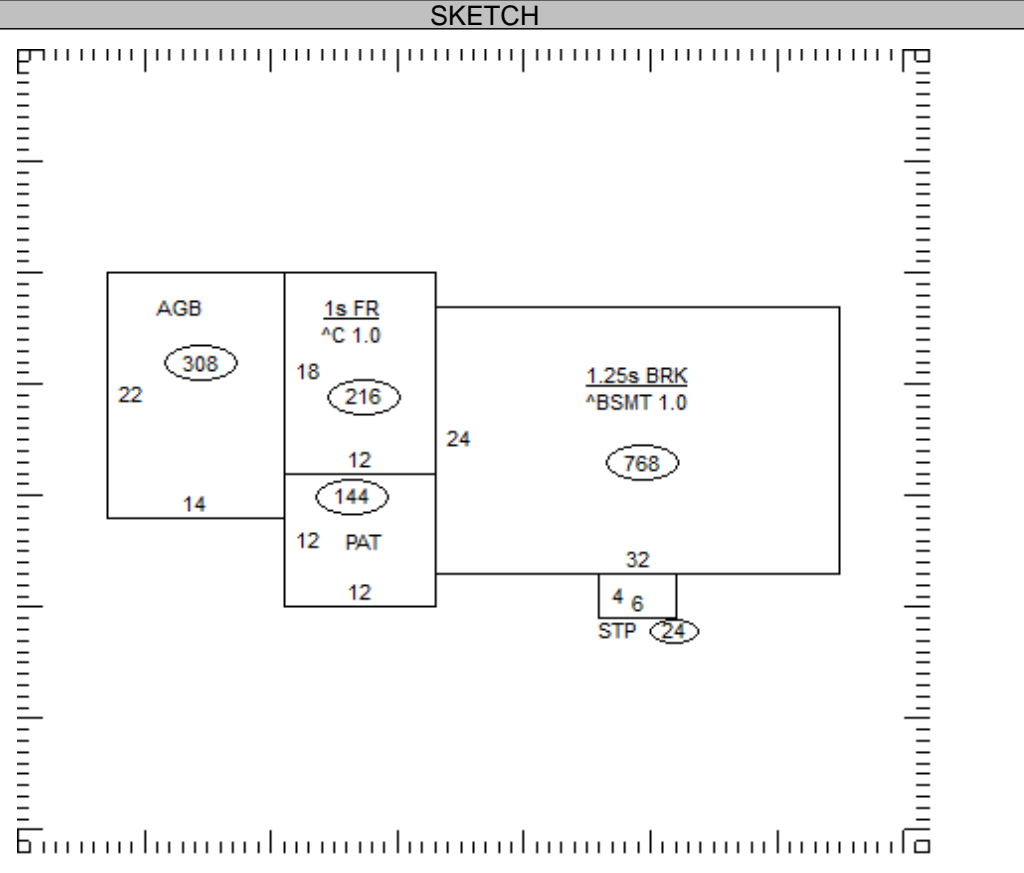

OCCUPANCY	ST.HT	SIZE	AREA	GRADE	PRICE	AGE	REMD	CND	UNADJ VAL	PHYS	PHYS VAL	FUNC	TRUE VAL
DWELLING	1.25	SK	1,176	C		1950		A	233,210	45	128,270		130,800
1													
2													
3													
4													
5													
6													
7													
8													
9													
10													
11													

05-027900.0000	TOTAL	130,800
----------------	--------------	---------

COMMENTS

Dwelling has an Economic Factor of 102%