

BUTLER TWP-COLDWATER CORP / COLDWATER SD
08-28-151-041

Property Class: 510

Neighborhood
000511-TS60

Map:
Block:
Card:

Bk: Pg:

05-012850.1709

LEGAL INFORMATION
NORTHFIELD ESTATES
FIFTH ADDITION
LOT#: 1709

KAUP ZACHARY J & BRIANNA L
KAUP ZACHARY J & BRIANNA L
1107 BUCKEYE DR
COLDWATER, OH 45828
Created in 2015 From 05-012850.0000 due to Split

	OWNERSHIP	ADDRESS	CITY	STATE	ZIP	DATE	AMOUNT	DEED:CONV#	JS	VALID
1	KAUP ZACHARY J & BRIANNA L	1107 BUCKEYE DR	COLDWATER	OH	45828	12/10/2020	485,000	SUC : 923	<input type="checkbox"/>	<input checked="" type="checkbox"/>
2	NIEKAMP KYLE T & JENNA L	1107 BUCKEYE DR	COLDWATER	OH	45828	11/07/2016	46,000	WDC : 797	<input type="checkbox"/>	<input checked="" type="checkbox"/>
3	KAUP STEPHEN J & LEAH C	412 E WALNUT ST	COLDWATER	OH	45828	03/21/2016	46,000	WDC : 163	<input type="checkbox"/>	<input checked="" type="checkbox"/>

X: TTO LISTER: JK DATE: 02/26/2019 TIME: 12:00:00 AM LETTER LETTER REC'D GIS CODE

STREET/ROAD	TOPOGRAPHY	PU-UTILITIES-PR	NEIGHBORHOOD	INFLUENCE FACTORS				PROPERTY LOCATION	
<input type="checkbox"/> PAVED <input type="checkbox"/> GRAVEL <input type="checkbox"/> DIRT <input type="checkbox"/> SIDEWALKS <input type="checkbox"/> CURBS	<input type="checkbox"/> LEVEL <input type="checkbox"/> HIGH <input type="checkbox"/> LOW <input type="checkbox"/> ROLLING <input type="checkbox"/> STANDARD	<input type="checkbox"/> WATER <input type="checkbox"/> SEWER <input type="checkbox"/> GAS <input type="checkbox"/> ELECTRIC <input type="checkbox"/> STANDARD	<input type="checkbox"/> IMPROVING <input type="checkbox"/> STATIC <input type="checkbox"/> DECLINING <input type="checkbox"/> OLD <input type="checkbox"/> STANDARD	<input type="checkbox"/> A. NO ROAD <input type="checkbox"/> B. TOPGRHY <input type="checkbox"/> C. Ex Front <input type="checkbox"/> D. QUANTITY <input type="checkbox"/> E. SZ/SHAPE	<input type="checkbox"/> F. RESTRICT <input type="checkbox"/> G. WOOD LT <input type="checkbox"/> H. VACANCY <input type="checkbox"/> I. WATER FRONT <input type="checkbox"/> J. OTHER/CDU	1107 BUCKEYE DR, COLDWATER			
								COMMENT	
								TY2022:Net Gen=\$5,064.72, Other Assessment=\$0.00 DE19 TTO; ADD DWLG DE17 RMV DEV DISCOUNT DE17 REVAL/RMV INFL FCTRS	
LAND TYPE		SIZE	M	RATE	C	INF	M	VALUE	C
F:Front		F101 D181	ST555	DP109	ADJ605			61,100	0
						TOTAL		61,100	0

VALUATION SUMMARY

VALUE YEAR	2023	2020	2019	2019	2017	2017	2017	
REASON FOR CHANGE	RAPP	RAPP	RCLS	NC	RAPP	MISC	MISC	
APPRAISED VALUE	<u>LAND</u> 61,100	44,100	36,900	36,900	36,900	30,800	23,100	
	<u>IMPR</u> 440,200	340,300	295,900	295,900	0	0	0	
	<u>TOTAL</u> 501,300	384,400	332,800	332,800	36,900	30,800	23,100	
ASSESSED VALUE	<u>LAND</u> 21,390	15,440	12,920	12,920	12,920	10,780	8,090	
	<u>IMPR</u> 154,070	119,110	103,570	103,570	0	0	0	
	<u>TOTAL</u> 175,460	134,550	116,490	116,490	12,920	10,780	8,090	

OCCUPANCY
 SF DU TR
 CONVERSION
BUILDING TYPE
 MOBILE HOME
 BI/TR LEVEL
 MOD/MAN

FLOOR	AREA	CONST	VALUE
1	2620	FR	281,150

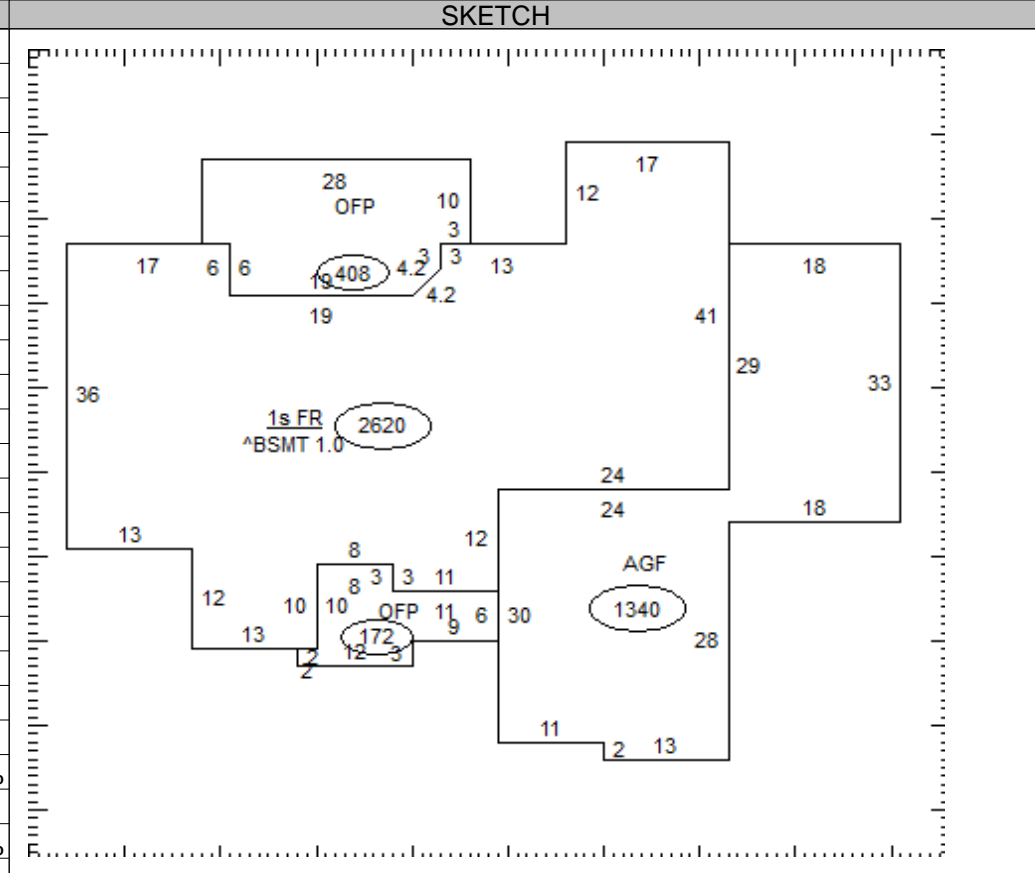

ROOFING
 METAL
 SLT/TLE
 SHINGLES
 SHAKES
 COMPOSITE

ROOF TYPE
 GABLE
 HIP
 GAMBREL
 MANSARD
 FLAT

BSMT	2620		37,470
SUBTOTAL			318,620

FLOORS B 1 2 3 U

CONCRETE

WOOD

TILE/COMPO

CARPET

MULTI-FAMILY #	0		0
BUILDING TYPE	100%		0
BSMT FINISH	0 S.F.		0
FIREPLACE #	1		4,400
HEATING	0 S.F.		0
AIR COND	2,620 S.F.		4,320
PLUMBING #	7		8,470
GARAGES & CARPORTS			33,100
EXTRA FEATURES			9,300
SUBTOTAL			378,210

INT. FINISH B 1 2 3 U

PLASTER/DW

PANELING

UNFINISHED

GRADE FACTOR			120 %
UNADJUSTED VALUE			453,850
FACTOR			100 %

ACCOMMODATIONS

OF ROOMS 7

BEDROOMS 4

FIREPLACES 1

HEAT & AC B 1 2 3 U

OCCUPANCY	ST.HT	SIZE	AREA	GRADE	PRICE	AGE	REMD	CND	UNADJ VAL	PHYS	PHYS VAL	FUNC	TRUE VAL
DWELLING	1	SK	2,620	B		2018		G	453,850	3	440,230		440,200
1													
2													
3													
4													
5													
6													
7													
8													
9													
10													
11													

NO HEAT

CTRL HEAT

HW/STEAM

ELECTRIC

HEAT PUMP

FLR/WALL

STVE/SPCE

GEOHERMAL

OUTSIDE

CTRL A/C

OCCUPANCY	ST.HT	SIZE	AREA	GRADE	PRICE	AGE	REMD	CND	UNADJ VAL	PHYS	PHYS VAL	FUNC	TRUE VAL
DWELLING	1	SK	2,620	B		2018		G	453,850	3	440,230		440,200
1													
2													
3													
4													
5													
6													
7													
8													
9													
10													
11													

PLUMBING BASE

X FULL BATH 1

X HALF BATH 1

X FIXTURES 2

05-012850.1709

TOTAL 440,200

COMMENTS

Dwelling has an Economic Factor of 100%



05-012850.1709

BUTLER TWP-COLDWATER CORP / COLDWATER SD
08-28-151-041

Property Class: 510
Neighborhood
000511-TS60

KAUP ZACHARY J & BRIANNA L
KAUP ZACHARY J & BRIANNA L
1107 BUCKEYE DR
COLDWATER, OH 45828

LEGAL INFORMATION
NORTHFIELD ESTATES
FIFTH ADDITION
LOT#: 1709

Map:
Block:
Card:

Created in 2018 From 05-012850.0000 due to Split

Bk: Pg:

OWNERSHIP	ADDRESS	CITY	STATE	ZIP	DATE	AMOUNT	DEED:CONV#	JS	VALID
1	TUMBUSCH RANDALL &	671 DOROTHY LN	SAINT HENRY	OH	45883	11/13/2015	0 WDC : 0	<input type="checkbox"/>	<input type="checkbox"/>
2							0 0	<input type="checkbox"/>	<input type="checkbox"/>
3							0 0	<input type="checkbox"/>	<input type="checkbox"/>

X: TTO LISTER: JK DATE: 02/26/2019 TIME: 12:00:00 AM LETTER LETTER REC'D GIS CODE

STREET/ROAD	TOPOGRAPHY	PU-UTILITIES-PR	NEIGHBORHOOD	INFLUENCE FACTORS	PROPERTY LOCATION
<input type="checkbox"/> PAVED	<input type="checkbox"/> LEVEL	<input type="checkbox"/> WATER	<input type="checkbox"/> IMPROVING	<input type="checkbox"/> A. NO ROAD <input type="checkbox"/> F. RESTRICT	1107 BUCKEYE DR, COLDWATER
<input type="checkbox"/> GRAVEL	<input type="checkbox"/> HIGH	<input type="checkbox"/> SEWER	<input type="checkbox"/> STATIC	<input type="checkbox"/> B. TOPGRHY <input type="checkbox"/> G. WOOD LT	COMMENT
<input type="checkbox"/> DIRT	<input type="checkbox"/> LOW	<input type="checkbox"/> GAS	<input type="checkbox"/> DECLINING	<input type="checkbox"/> C. Ex Front <input type="checkbox"/> H. VACANCY	
<input type="checkbox"/> SIDEWALKS	<input type="checkbox"/> ROLLING	<input type="checkbox"/> ELECTRIC	<input type="checkbox"/> OLD	<input type="checkbox"/> D. QUANTITY <input type="checkbox"/> I. WATER FRONT	
<input type="checkbox"/> CURBS	<input type="checkbox"/> STANDARD	<input type="checkbox"/> STANDARD	<input type="checkbox"/> STANDARD	<input type="checkbox"/> E. SZ/SHAPE <input type="checkbox"/> J. OTHER/CDU	

LAND COMPUTATIONS							
LAND TYPE	SIZE	M	RATE	C	INF	M	VALUE C
TOTAL						61,100	0

VALUATION SUMMARY

VALUE YEAR	REASON FOR CHANGE	APPRaised	LAND IMPR	TOTAL	ASSESSED	LAND IMPR	TOTAL

OCCUPANCY	EXTERIOR	FLOOR	AREA	CONST	VALUE
<input type="checkbox"/> SF <input type="checkbox"/> DU <input type="checkbox"/> TR	<input type="checkbox"/> WOOD				
<input type="checkbox"/> CONVERSION	<input type="checkbox"/> STUCCO				
BUILDING TYPE	<input type="checkbox"/> ALM/VYNL				
<input type="checkbox"/> MOBILE HOME	<input type="checkbox"/> CONC BLK				
<input type="checkbox"/> BI/TR LEVEL	<input type="checkbox"/> METAL				
<input type="checkbox"/> MOD/MAN	<input type="checkbox"/> BRICK				
<input type="checkbox"/>	<input type="checkbox"/> STONE				

ROOFING	ROOF TYPE
<input type="checkbox"/> METAL	<input type="checkbox"/> GABLE
<input type="checkbox"/> SLT/TLE	<input type="checkbox"/> HIP
<input type="checkbox"/> SHINGLES	<input type="checkbox"/> GAMBREL
<input type="checkbox"/> SHAKES	<input type="checkbox"/> MANSARD
<input type="checkbox"/> COMPOSITE	<input type="checkbox"/> FLAT

FLOORS	B	1	2	3	U
CONCRETE	<input type="checkbox"/>	<input type="checkbox"/>	<input type="checkbox"/>	<input type="checkbox"/>	<input type="checkbox"/>
WOOD	<input type="checkbox"/>	<input type="checkbox"/>	<input type="checkbox"/>	<input type="checkbox"/>	<input type="checkbox"/>
TILE/COMPO	<input type="checkbox"/>	<input type="checkbox"/>	<input type="checkbox"/>	<input type="checkbox"/>	<input type="checkbox"/>
CARPET	<input type="checkbox"/>	<input type="checkbox"/>	<input type="checkbox"/>	<input type="checkbox"/>	<input type="checkbox"/>
INT. FINISH	B	1	2	3	U
PLASTER/DW	<input type="checkbox"/>	<input type="checkbox"/>	<input type="checkbox"/>	<input type="checkbox"/>	<input type="checkbox"/>
PANELING	<input type="checkbox"/>	<input type="checkbox"/>	<input type="checkbox"/>	<input type="checkbox"/>	<input type="checkbox"/>
UNFINISHED	<input type="checkbox"/>	<input type="checkbox"/>	<input type="checkbox"/>	<input type="checkbox"/>	<input type="checkbox"/>
ACCOMMODATIONS					
# OF ROOMS					
BEDROOMS					
FIREPLACES					
HEAT & AC	B	1	2	3	U
NO HEAT	<input type="checkbox"/>	<input type="checkbox"/>	<input type="checkbox"/>	<input type="checkbox"/>	<input type="checkbox"/>
CTRL HEAT	<input type="checkbox"/>	<input type="checkbox"/>	<input type="checkbox"/>	<input type="checkbox"/>	<input type="checkbox"/>
HW/STEAM	<input type="checkbox"/>	<input type="checkbox"/>	<input type="checkbox"/>	<input type="checkbox"/>	<input type="checkbox"/>
ELECTRIC	<input type="checkbox"/>	<input type="checkbox"/>	<input type="checkbox"/>	<input type="checkbox"/>	<input type="checkbox"/>
HEAT PUMP	<input type="checkbox"/>	<input type="checkbox"/>	<input type="checkbox"/>	<input type="checkbox"/>	<input type="checkbox"/>
FLR/WALL	<input type="checkbox"/>	<input type="checkbox"/>	<input type="checkbox"/>	<input type="checkbox"/>	<input type="checkbox"/>
STVE/SPCE	<input type="checkbox"/>	<input type="checkbox"/>	<input type="checkbox"/>	<input type="checkbox"/>	<input type="checkbox"/>
GEO THERMAL	<input type="checkbox"/>	<input type="checkbox"/>	<input type="checkbox"/>	<input type="checkbox"/>	<input type="checkbox"/>
OUTSIDE	<input type="checkbox"/>	<input type="checkbox"/>	<input type="checkbox"/>	<input type="checkbox"/>	<input type="checkbox"/>
CTRL A/C	<input type="checkbox"/>	<input type="checkbox"/>	<input type="checkbox"/>	<input type="checkbox"/>	<input type="checkbox"/>
PLUMBING	BASE <input type="checkbox"/>				
X FULL BATH					
X HALF BATH					
X FIXTURES					

SUBTOTAL		0
MULTI-FAMILY #	0	0
BUILDING TYPE	000%	0
BSMT FINISH	0 S.F.	0
FIREPLACE #	0	0
HEATING	0 S.F.	0
AIR COND	0 S.F.	0
PLUMBING #	0	0
GARAGES & CARPORTS		0
EXTRA FEATURES		0
SUBTOTAL		0
GRADE FACTOR		%
UNADJUSTED VALUE		0
FACTOR		%

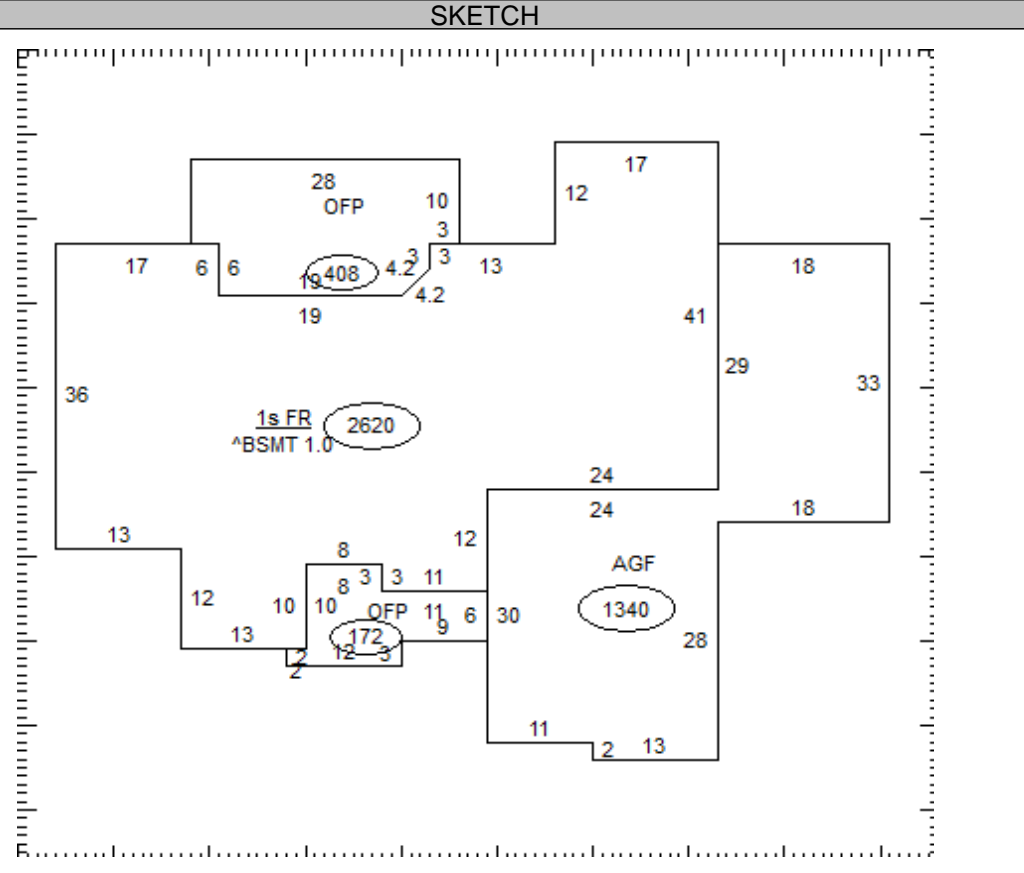

OCCUPANCY	ST.HT	SIZE	AREA	GRADE	PRICE	AGE	REMD	CND	UNADJ VAL	PHYS	PHYS VAL	FUNC	TRUE VAL
DWELLING		SK											
1													
2													
3													
4													
5													
6													
7													
8													
9													
10													
11													

05-012850.1709

TOTAL 0

COMMENTS