



05-012551.0116

HOYING MICHAEL B & KELLY M
HOYING MICHAEL B & KELLY M

1011 N ELM ST
COLDWATER, OH 45828

Created in 2009 From 05-012551.0100 due to Split

BUTLER TWP-COLDWATER CORP / COLDWATER SD
08-28-251-040

LEGAL INFORMATION
WENNING ACRES FOURTH ADDITION

LOT#: 1655

Property Class: 510

Neighborhood
000511-TS60

Map:

Block:

Card:

Bk: Pg:

	OWNERSHIP	ADDRESS	CITY	STATE	ZIP	DATE	AMOUNT	DEED:CONV#	JS	VALID
1	HOYING MICHAEL B & KELLY M	1011 N ELM ST	COLDWATER	OH	45828	09/03/2021	78,900	WDC : 751	<input type="checkbox"/>	<input checked="" type="checkbox"/>
2	WENNING ACRES INC	706 N SECOND ST	COLDWATER	OH	45828	12/14/2016	0	QCE : X : 0	<input type="checkbox"/>	<input type="checkbox"/>
3	WENNING KEITH A & KATIE M	4356 BUSCHUR RD	COLDWATER	OH	45828	03/24/2015	49,300	WDC : 176	<input type="checkbox"/>	<input checked="" type="checkbox"/>

X:	<input type="checkbox"/> TTO	LISTER: TK	DATE: 07/03/2023	TIME: 12:00:00 AM	<input checked="" type="checkbox"/> LETTER	<input type="checkbox"/> LETTER REC'D	GIS CODE
----	------------------------------	------------	------------------	-------------------	--	---------------------------------------	----------

STREET/ROAD	TOPOGRAPHY	PU-UTILITIES-PR	NEIGHBORHOOD	INFLUENCE FACTORS	PROPERTY LOCATION	
<input type="checkbox"/> PAVED <input type="checkbox"/> GRAVEL <input type="checkbox"/> DIRT <input type="checkbox"/> SIDEWALKS <input type="checkbox"/> CURBS	<input type="checkbox"/> LEVEL <input type="checkbox"/> HIGH <input type="checkbox"/> LOW <input type="checkbox"/> ROLLING <input type="checkbox"/> STANDARD	<input type="checkbox"/> WATER <input type="checkbox"/> SEWER <input type="checkbox"/> GAS <input type="checkbox"/> ELECTRIC <input type="checkbox"/> STANDARD	<input type="checkbox"/> IMPROVING <input type="checkbox"/> STATIC <input type="checkbox"/> DECLINING <input type="checkbox"/> OLD <input type="checkbox"/> STANDARD	<input type="checkbox"/> A. NO ROAD <input type="checkbox"/> B. TOPGRHY <input type="checkbox"/> C. Ex Front <input type="checkbox"/> D. QUANTITY <input type="checkbox"/> E. SZ/SHAPE	<input type="checkbox"/> F. RESTRICT <input type="checkbox"/> G. WOOD LT <input type="checkbox"/> H. VACANCY <input type="checkbox"/> I. WATER FRONT <input type="checkbox"/> J. OTHER/CDU	1011 N ELM ST, COLDWATER COMMENT TY2022:Net Gen=\$492.72, Other Assessment=\$0.00 DE17 REVAL/RMV INFL FCTRS DE23 NOH; NEW DWELLING (\$575,000)

LAND COMPUTATIONS						
LAND TYPE	SIZE	M	RATE	C	INF	M VALUE C
F:Front	F139 D140	ST555 DP96 ADJ533				74,100 0
					TOTAL	74,100 0

VALUATION SUMMARY						
VALUE YEAR	2023	2023	2020	2017	2017	
REASON FOR CHANGE	RCLS	NC	RAPP	RAPP	MISC	
APPRaised	<u>LAND</u> 74,100	74,100	37,400	31,400	26,200	
VALUE	<u>IMPR</u> 445,100	445,100	0	0	0	
	<u>TOTAL</u> 519,200	519,200	37,400	31,400	26,200	
ASSESSED	<u>LAND</u> 25,940	25,940	13,090	10,990	9,170	
VALUE	<u>IMPR</u> 155,790	155,790	0	0	0	
	<u>TOTAL</u> 181,730	181,730	13,090	10,990	9,170	

OCCUPANCY		EXTERIOR	
<input checked="" type="checkbox"/> SF	<input type="checkbox"/> DU	<input type="checkbox"/> WOOD	<input type="checkbox"/> STUCCO
<input type="checkbox"/> TR	<input type="checkbox"/> CONVERSION	<input type="checkbox"/> ALM/VYNL	<input type="checkbox"/> CONC BLK
BUILDING TYPE		<input type="checkbox"/> METAL	<input type="checkbox"/> BRICK
<input type="checkbox"/> MOBILE HOME	<input type="checkbox"/> BI/TR LEVEL	<input type="checkbox"/> BRICK	<input checked="" type="checkbox"/> STONE
<input type="checkbox"/> MOD/MAN	<input type="checkbox"/>		

ROOFING		ROOF TYPE	
<input type="checkbox"/> METAL	<input type="checkbox"/> SLT/TLE	<input type="checkbox"/> GABLE	<input checked="" type="checkbox"/> HIP
<input checked="" type="checkbox"/> SHINGLES	<input type="checkbox"/> SHAKES	<input type="checkbox"/> GAMBREL	<input type="checkbox"/> MANSARD
<input type="checkbox"/>	<input type="checkbox"/> COMPOSITE	<input type="checkbox"/>	<input type="checkbox"/> FLAT

FLOORS		B	1	2	3	U
CONCRETE	<input type="checkbox"/>	<input type="checkbox"/>	<input type="checkbox"/>	<input type="checkbox"/>	<input type="checkbox"/>	<input type="checkbox"/>
WOOD	<input type="checkbox"/>	<input type="checkbox"/>	<input type="checkbox"/>	<input type="checkbox"/>	<input type="checkbox"/>	<input type="checkbox"/>
TILE/COMPO	<input type="checkbox"/>	<input checked="" type="checkbox"/>	<input type="checkbox"/>	<input type="checkbox"/>	<input type="checkbox"/>	<input type="checkbox"/>
CARPET	<input type="checkbox"/>	<input checked="" type="checkbox"/>	<input type="checkbox"/>	<input type="checkbox"/>	<input type="checkbox"/>	<input type="checkbox"/>

INT. FINISH		B	1	2	3	U
PLASTER/DW	<input type="checkbox"/>	<input checked="" type="checkbox"/>	<input type="checkbox"/>	<input type="checkbox"/>	<input type="checkbox"/>	<input type="checkbox"/>
PANELING	<input type="checkbox"/>	<input type="checkbox"/>	<input type="checkbox"/>	<input type="checkbox"/>	<input type="checkbox"/>	<input type="checkbox"/>
UNFINISHED	<input checked="" type="checkbox"/>	<input type="checkbox"/>	<input type="checkbox"/>	<input type="checkbox"/>	<input type="checkbox"/>	<input type="checkbox"/>

ACCOMMODATIONS		B	1	2	3	U
# OF ROOMS		8				
BEDROOMS		4				
FIREPLACES						

HEAT & AC		B	1	2	3	U
NO HEAT	<input type="checkbox"/>	<input type="checkbox"/>	<input type="checkbox"/>	<input type="checkbox"/>	<input type="checkbox"/>	<input type="checkbox"/>
CTRL HEAT	<input type="checkbox"/>	<input checked="" type="checkbox"/>	<input type="checkbox"/>	<input type="checkbox"/>	<input type="checkbox"/>	<input type="checkbox"/>
HW/STEAM	<input type="checkbox"/>	<input type="checkbox"/>	<input type="checkbox"/>	<input type="checkbox"/>	<input type="checkbox"/>	<input type="checkbox"/>
ELECTRIC	<input type="checkbox"/>	<input type="checkbox"/>	<input type="checkbox"/>	<input type="checkbox"/>	<input type="checkbox"/>	<input type="checkbox"/>
HEAT PUMP	<input type="checkbox"/>	<input type="checkbox"/>	<input type="checkbox"/>	<input type="checkbox"/>	<input type="checkbox"/>	<input type="checkbox"/>
FLR/WALL	<input type="checkbox"/>	<input type="checkbox"/>	<input type="checkbox"/>	<input type="checkbox"/>	<input type="checkbox"/>	<input type="checkbox"/>
STVE/SPCE	<input type="checkbox"/>	<input type="checkbox"/>	<input type="checkbox"/>	<input type="checkbox"/>	<input type="checkbox"/>	<input type="checkbox"/>
GEOHERMAL	<input type="checkbox"/>	<input type="checkbox"/>	<input type="checkbox"/>	<input type="checkbox"/>	<input type="checkbox"/>	<input type="checkbox"/>
OUTSIDE	<input type="checkbox"/>	<input type="checkbox"/>	<input type="checkbox"/>	<input type="checkbox"/>	<input type="checkbox"/>	<input type="checkbox"/>
CTRL A/C	<input type="checkbox"/>	<input checked="" type="checkbox"/>	<input type="checkbox"/>	<input type="checkbox"/>	<input type="checkbox"/>	<input type="checkbox"/>

PLUMBING		BASE	
X FULL BATH		1	
X HALF BATH		1	
X FIXTURES		2	

FLOOR	AREA	CONST	VALUE
1	2219	FR	249,970
BSMT	2219		31,730
SUBTOTAL			281,700
MULTI-FAMILY #	0		0
BUILDING TYPE	100%		0
BSMT FINISH	0 S.F.		0
FIREPLACE #	0		0
HEATING	0 S.F.		0
AIR COND	2,219 S.F.		3,660
PLUMBING #	7		8,470
GARAGES & CARPORTS			27,700
EXTRA FEATURES			24,300
SUBTOTAL			345,830
GRADE FACTOR			130 %
UNADJUSTED VALUE			449,580
FACTOR			100 %

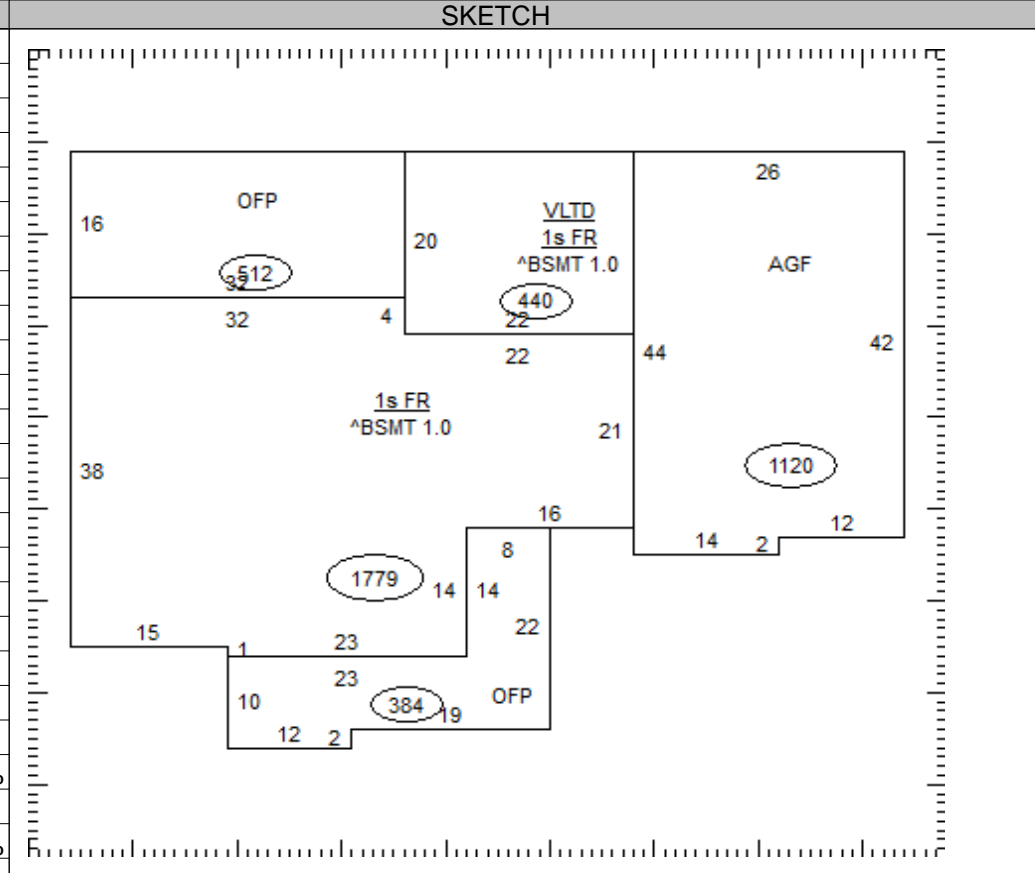

OCCUPANCY	ST.HT	SIZE	AREA	GRADE	PRICE	AGE	REMD	CND	UNADJ VAL	PHYS	PHYS VAL	FUNC	TRUE VAL
DWELLING	1	SK	2,219	B+		2022		G	449,580	1	445,080		445,100
1													
2													
3													
4													
5													
6													
7													
8													
9													
10													
11													

05-012551.0116 TOTAL 445,100

COMMENTS

Dwelling has an Economic Factor of 100%

BUTLER TWP-COLDWATER CORP / COLDWATER SD
08-28-251-040

Property Class: 510

Neighborhood
000511-TS60

Map:
Block:
Card:

Bk: Pg:

05-012551.0116

HOYING MICHAEL B & KELLY M
HOYING MICHAEL B & KELLY M
1011 N ELM ST
COLDWATER, OH 45828
Created in 2009 From 05-012551.0100 due to Split

LEGAL INFORMATION
WENNING ACRES FOURTH ADDITION

LOT#: 1655

	OWNERSHIP	ADDRESS	CITY	STATE	ZIP	DATE	AMOUNT	DEED:CONV#	JS	VALID
1	WENNING ACRES INC	706 N SECOND ST	COLDWATER	OH	45828	11/19/2013	49,300	WDC : 796	<input type="checkbox"/>	<input checked="" type="checkbox"/>
2	STEINBRUNNER TROY &	805 W VINE ST	COLDWATER	OH	45828	07/01/2013	49,300	WDC : 412	<input type="checkbox"/>	<input checked="" type="checkbox"/>
3	WENNING ACRES INC	706 N SECOND ST	COLDWATER	OH	45828	11/24/2009	0	: 0	<input type="checkbox"/>	<input type="checkbox"/>

X: TTO LISTER: TK DATE: 07/03/2023 TIME: 12:00:00 AM LETTER LETTER REC'D GIS CODE

STREET/ROAD TOPOGRAPHY PU-UTILITIES-PR NEIGHBORHOOD INFLUENCE FACTORS PROPERTY LOCATION

- PAVED LEVEL WATER IMPROVING A. NO ROAD F. RESTRICT
- GRAVEL HIGH SEWER STATIC B. TOPGRHY G. WOOD LT
- DIRT LOW GAS DECLINING C. Ex Front H. VACANCY
- SIDEWALKS ROLLING ELECTRIC OLD D. QUANTITY I. WATER FRONT
- CURBS STANDARD STANDARD E. SZ/SHAPE J. OTHER/CDU

1011 N ELM ST, COLDWATER
COMMENT

LAND COMPUTATIONS

LAND TYPE	SIZE	M	RATE	C	INF	M	VALUE	C
TOTAL						74,100	0	

VALUATION SUMMARY

VALUE YEAR	REASON FOR CHANGE	APPRaised	LAND IMPR	VALUE	TOTAL	ASSESSED	LAND IMPR	VALUE	TOTAL

OCCUPANCY	EXTERIOR	FLOOR	AREA	CONST	VALUE
<input type="checkbox"/> SF <input type="checkbox"/> DU <input type="checkbox"/> TR	<input type="checkbox"/> WOOD				
<input type="checkbox"/> CONVERSION	<input type="checkbox"/> STUCCO				
BUILDING TYPE	<input type="checkbox"/> ALM/VYNL				
<input type="checkbox"/> MOBILE HOME	<input type="checkbox"/> CONC BLK				
<input type="checkbox"/> BI/TR LEVEL	<input type="checkbox"/> METAL				
<input type="checkbox"/> MOD/MAN	<input type="checkbox"/> BRICK				
<input type="checkbox"/>	<input type="checkbox"/> STONE				

ROOFING	ROOF TYPE
<input type="checkbox"/> METAL	<input type="checkbox"/> GABLE
<input type="checkbox"/> SLT/TLE	<input type="checkbox"/> HIP
<input type="checkbox"/> SHINGLES	<input type="checkbox"/> GAMBREL
<input type="checkbox"/> SHAKES	<input type="checkbox"/> MANSARD
<input type="checkbox"/> COMPOSITE	<input type="checkbox"/> FLAT

FLOORS	B	1	2	3	U
CONCRETE	<input type="checkbox"/>	<input type="checkbox"/>	<input type="checkbox"/>	<input type="checkbox"/>	<input type="checkbox"/>
WOOD	<input type="checkbox"/>	<input type="checkbox"/>	<input type="checkbox"/>	<input type="checkbox"/>	<input type="checkbox"/>
TILE/COMPO	<input type="checkbox"/>	<input type="checkbox"/>	<input type="checkbox"/>	<input type="checkbox"/>	<input type="checkbox"/>
CARPET	<input type="checkbox"/>	<input type="checkbox"/>	<input type="checkbox"/>	<input type="checkbox"/>	<input type="checkbox"/>
INT. FINISH	B	1	2	3	U
PLASTER/DW	<input type="checkbox"/>	<input type="checkbox"/>	<input type="checkbox"/>	<input type="checkbox"/>	<input type="checkbox"/>
PANELING	<input type="checkbox"/>	<input type="checkbox"/>	<input type="checkbox"/>	<input type="checkbox"/>	<input type="checkbox"/>
UNFINISHED	<input type="checkbox"/>	<input type="checkbox"/>	<input type="checkbox"/>	<input type="checkbox"/>	<input type="checkbox"/>
ACCOMMODATIONS					
# OF ROOMS					
BEDROOMS					
FIREPLACES					
HEAT & AC	B	1	2	3	U
NO HEAT	<input type="checkbox"/>	<input type="checkbox"/>	<input type="checkbox"/>	<input type="checkbox"/>	<input type="checkbox"/>
CTRL HEAT	<input type="checkbox"/>	<input type="checkbox"/>	<input type="checkbox"/>	<input type="checkbox"/>	<input type="checkbox"/>
HW/STEAM	<input type="checkbox"/>	<input type="checkbox"/>	<input type="checkbox"/>	<input type="checkbox"/>	<input type="checkbox"/>
ELECTRIC	<input type="checkbox"/>	<input type="checkbox"/>	<input type="checkbox"/>	<input type="checkbox"/>	<input type="checkbox"/>
HEAT PUMP	<input type="checkbox"/>	<input type="checkbox"/>	<input type="checkbox"/>	<input type="checkbox"/>	<input type="checkbox"/>
FLR/WALL	<input type="checkbox"/>	<input type="checkbox"/>	<input type="checkbox"/>	<input type="checkbox"/>	<input type="checkbox"/>
STVE/SPCE	<input type="checkbox"/>	<input type="checkbox"/>	<input type="checkbox"/>	<input type="checkbox"/>	<input type="checkbox"/>
GEO THERMAL	<input type="checkbox"/>	<input type="checkbox"/>	<input type="checkbox"/>	<input type="checkbox"/>	<input type="checkbox"/>
OUTSIDE	<input type="checkbox"/>	<input type="checkbox"/>	<input type="checkbox"/>	<input type="checkbox"/>	<input type="checkbox"/>
CTRL A/C	<input type="checkbox"/>	<input type="checkbox"/>	<input type="checkbox"/>	<input type="checkbox"/>	<input type="checkbox"/>
PLUMBING					BASE <input type="checkbox"/>
X FULL BATH					
X HALF BATH					
X FIXTURES					

SUBTOTAL		0
MULTI-FAMILY #	0	0
BUILDING TYPE	000%	0
BSMT FINISH	0 S.F.	0
FIREPLACE #	0	0
HEATING	0 S.F.	0
AIR COND	0 S.F.	0
PLUMBING #	0	0
GARAGES & CARPORTS		0
EXTRA FEATURES		0
SUBTOTAL		0
GRADE FACTOR		%
UNADJUSTED VALUE		0
FACTOR		%

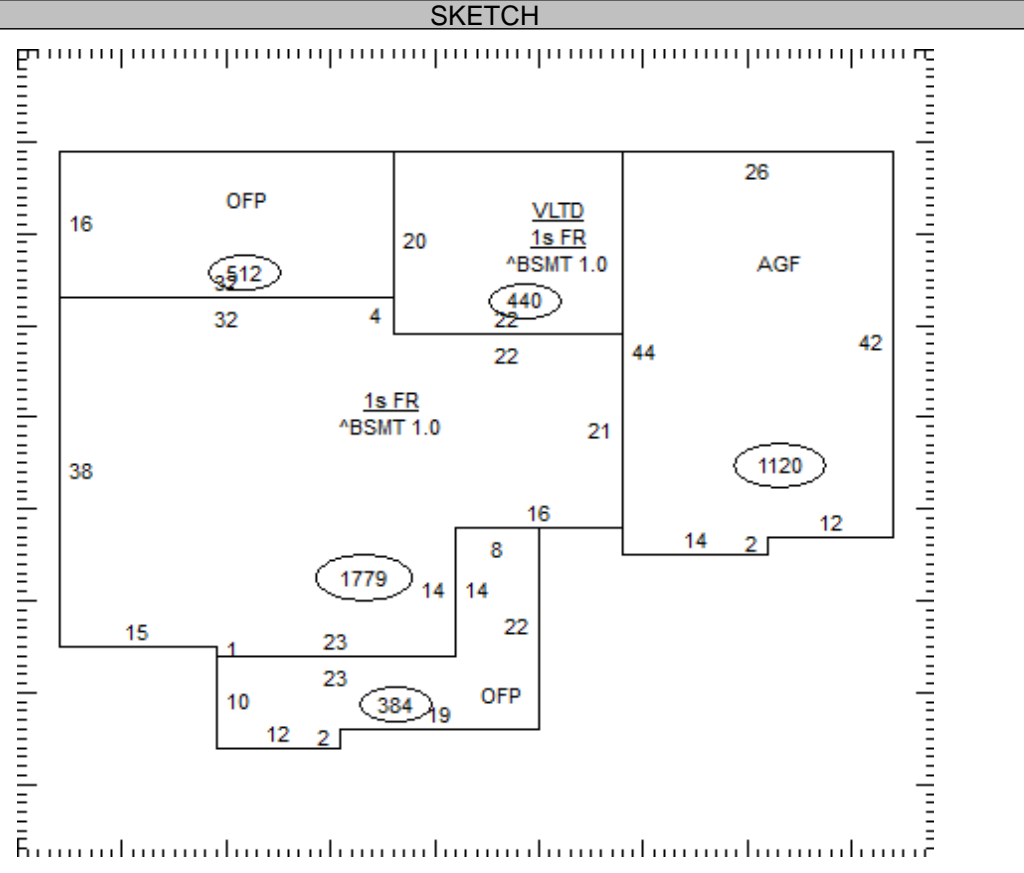

OCCUPANCY	ST.HT	SIZE	AREA	GRADE	PRICE	AGE	REMD	CND	UNADJ VAL	PHYS	PHYS VAL	FUNC	TRUE VAL
DWELLING		SK											
1													
2													
3													
4													
5													
6													
7													
8													
9													
10													
11													

05-012551.0116

TOTAL 0

COMMENTS