



04-002300.0000

BUTLER TWP / ST HENRY SD

11-11-100-004

Page 1 of 1
 Property Class: 510
 Neighborhood
 009045-R150
 Map: 21B
 Block:
 Card: 29
 Bk: Pg:

LUTHMAN BRADLEY D & MELINDA S

LUTHMAN BRADLEY D & MELINDA S

5130 PHILOTHEA RD

SAINT HENRY, OH 45883

LEGAL INFORMATION

PT E 1/2 NW

RTS: 002-07-11

Acres:2.0000

	OWNERSHIP	ADDRESS	CITY	STATE	ZIP	DATE	AMOUNT	DEED:CONV#	JS	VALID
1	LUTHMAN BRADLEY D &	5130 PHILOTHEA RD	SAINT HENRY	OH	45883	01/07/2022	340,000	WDC : 13	<input checked="" type="checkbox"/>	<input type="checkbox"/>
2	RIPPLOH SUSAN M TRUSTEE	444 E 7TH ST	MINSTER	OH	45865	01/22/2021	0	QCE : X : 0	<input type="checkbox"/>	<input type="checkbox"/>
3	BUENING PAUL H & JUANITA M	5130 PHILOTHEA RD	ST HENRY	OH	45883	10/22/2003	0	: X : 0	<input type="checkbox"/>	<input type="checkbox"/>

X: TTO LISTER: EE DATE: 04/18/2005 TIME: 12:00:00 AM LETTER LETTER REC'D GIS CODE

STREET/ROAD		TOPOGRAPHY	PU-UTILITIES-PR	NEIGHBORHOOD	INFLUENCE FACTORS				PROPERTY LOCATION	
<input checked="" type="checkbox"/>	PAVED	<input checked="" type="checkbox"/> LEVEL	<input type="checkbox"/> WATER	<input type="checkbox"/> IMPROVING	<input type="checkbox"/> A. NO ROAD	<input type="checkbox"/> F. RESTRICT	5130 PHILOTHEA RD, ST HENRY			
<input type="checkbox"/>	GRAVEL	<input type="checkbox"/> HIGH	<input type="checkbox"/> SEWER	<input type="checkbox"/> STATIC	<input type="checkbox"/> B. TOPGRHY	<input type="checkbox"/> G. WOOD LT	COMMENT			
<input type="checkbox"/>	DIRT	<input type="checkbox"/> LOW	<input type="checkbox"/> GAS	<input type="checkbox"/> DECLINING	<input type="checkbox"/> C. Ex Front	<input type="checkbox"/> H. VACANCY	TY2022:Net Gen=\$2,260.56, Other			
<input type="checkbox"/>	SIDEWALKS	<input type="checkbox"/> ROLLING	<input type="checkbox"/> ELECTRIC	<input type="checkbox"/> OLD	<input type="checkbox"/> D. QUANTITY	<input type="checkbox"/> I. WATER FRONT	Assessment=\$0.00			
<input type="checkbox"/>	CURBS	<input type="checkbox"/> STANDARD	<input checked="" type="checkbox"/> STANDARD	<input type="checkbox"/> STANDARD	<input type="checkbox"/> E. SZ/SHAPE	<input type="checkbox"/> J. OTHER/CDU				

LAND COMPUTATIONS

LAND TYPE	SIZE	M	RATE	C	INF	M	VALUE	C
HS:Home Site	AC:1	23230				23,200		0
SM:Small Acreage	AC:1	8500				8,500		0
Total Acres: 2.0000					TOTAL	31,700		0

VALUATION SUMMARY

VALUE YEAR	2023	2020	2017					
REASON FOR CHANGE	RAPP	RAPP	RAPP					
APPRaised	<u>LAND</u>	31,700	24,700	23,500				
VALUE	<u>IMPR</u>	214,300	156,800	151,100				
	<u>TOTAL</u>	246,000	181,500	174,600				
ASSESSED	<u>LAND</u>	11,100	8,650	8,230				
	<u>IMPR</u>	75,010	54,880	52,890				
	<u>TOTAL</u>	86,110	63,530	61,120				

OCCUPANCY	EXTERIOR
<input checked="" type="checkbox"/> SF <input type="checkbox"/> DU <input type="checkbox"/> TR	<input type="checkbox"/> WOOD
<input type="checkbox"/> CONVERSION	<input type="checkbox"/> STUCCO
BUILDING TYPE	<input type="checkbox"/> ALM/VYNL
<input type="checkbox"/> MOBILE HOME	<input type="checkbox"/> CONC BLK
<input type="checkbox"/> BI/TR LEVEL	<input type="checkbox"/> METAL
<input type="checkbox"/> MOD/MAN	<input checked="" type="checkbox"/> BRICK
<input type="checkbox"/> _____	<input type="checkbox"/> STONE

ROOFING	ROOF TYPE
<input type="checkbox"/> METAL	<input checked="" type="checkbox"/> GABLE
<input type="checkbox"/> SLT/TLE	<input type="checkbox"/> HIP
<input checked="" type="checkbox"/> SHINGLES	<input type="checkbox"/> GAMBREL
<input type="checkbox"/> SHAKES	<input type="checkbox"/> MANSARD
<input type="checkbox"/> COMPOSITE	<input type="checkbox"/> FLAT

FLOORS	B	1	2	3	U
CONCRETE	<input checked="" type="checkbox"/>	<input type="checkbox"/>	<input type="checkbox"/>	<input type="checkbox"/>	<input type="checkbox"/>
WOOD	<input type="checkbox"/>	<input type="checkbox"/>	<input type="checkbox"/>	<input type="checkbox"/>	<input type="checkbox"/>
TILE/COMPO	<input type="checkbox"/>	<input checked="" type="checkbox"/>	<input type="checkbox"/>	<input type="checkbox"/>	<input type="checkbox"/>
CARPET	<input type="checkbox"/>	<input checked="" type="checkbox"/>	<input type="checkbox"/>	<input type="checkbox"/>	<input type="checkbox"/>
INT. FINISH	B	1	2	3	U
PLASTER/DW	<input type="checkbox"/>	<input checked="" type="checkbox"/>	<input type="checkbox"/>	<input type="checkbox"/>	<input type="checkbox"/>
PANELING	<input type="checkbox"/>	<input type="checkbox"/>	<input type="checkbox"/>	<input type="checkbox"/>	<input type="checkbox"/>
UNFINISHED	<input type="checkbox"/>	<input type="checkbox"/>	<input type="checkbox"/>	<input type="checkbox"/>	<input type="checkbox"/>
ACCOMMODATIONS					
# OF ROOMS		6			
BEDROOMS		3			
FIREPLACES		1			
HEAT & AC	B	1	2	3	U
NO HEAT	<input type="checkbox"/>	<input type="checkbox"/>	<input type="checkbox"/>	<input type="checkbox"/>	<input type="checkbox"/>
CTRL HEAT	<input checked="" type="checkbox"/>	<input checked="" type="checkbox"/>	<input type="checkbox"/>	<input type="checkbox"/>	<input type="checkbox"/>
HW/STEAM	<input type="checkbox"/>	<input type="checkbox"/>	<input type="checkbox"/>	<input type="checkbox"/>	<input type="checkbox"/>
ELECTRIC	<input type="checkbox"/>	<input type="checkbox"/>	<input type="checkbox"/>	<input type="checkbox"/>	<input type="checkbox"/>
HEAT PUMP	<input type="checkbox"/>	<input type="checkbox"/>	<input type="checkbox"/>	<input type="checkbox"/>	<input type="checkbox"/>
FLR/WALL	<input type="checkbox"/>	<input type="checkbox"/>	<input type="checkbox"/>	<input type="checkbox"/>	<input type="checkbox"/>
STVE/SPCE	<input type="checkbox"/>	<input type="checkbox"/>	<input type="checkbox"/>	<input type="checkbox"/>	<input type="checkbox"/>
GEOHERMAL	<input type="checkbox"/>	<input type="checkbox"/>	<input type="checkbox"/>	<input type="checkbox"/>	<input type="checkbox"/>
OUTSIDE	<input type="checkbox"/>	<input type="checkbox"/>	<input type="checkbox"/>	<input type="checkbox"/>	<input type="checkbox"/>
CTRL A/C	<input checked="" type="checkbox"/>	<input checked="" type="checkbox"/>	<input type="checkbox"/>	<input type="checkbox"/>	<input type="checkbox"/>
PLUMBING	BASE <input checked="" type="checkbox"/>				
X FULL BATH					
X HALF BATH		1			
X FIXTURES					

FLOOR	AREA	CONST	VALUE
1	1716	BRK	230,850
BSMT	1716		24,540
SUBTOTAL			255,390
MULTI-FAMILY #	0		0
BUILDING TYPE	100%		0
BSMT FINISH	858 S.F.		12,270
FIREPLACE #	1		4,400
HEATING	0 S.F.		0
AIR COND	2,574 S.F.		4,250
PLUMBING #	2		2,420
GARAGES & CARPORTS			16,800
EXTRA FEATURES			20,500
SUBTOTAL			316,030
GRADE FACTOR			100 %
UNADJUSTED VALUE			316,030
FACTOR			100 %

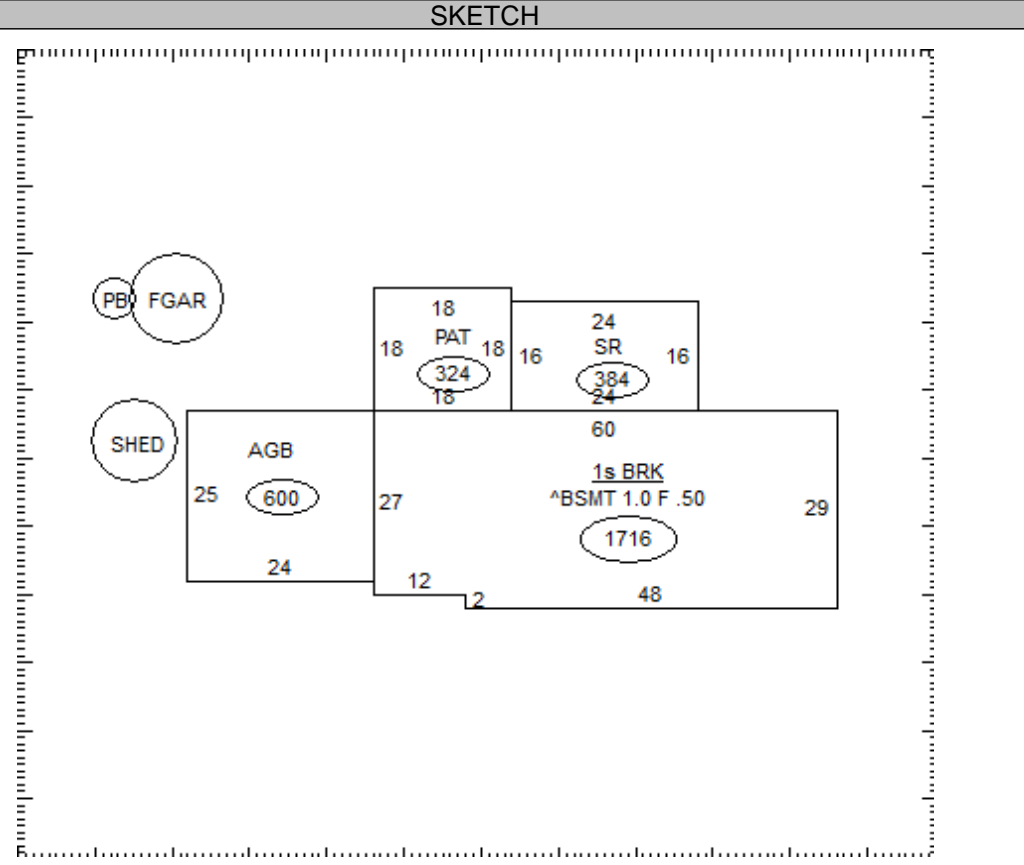

OCCUPANCY	ST.HT	SIZE	AREA	GRADE	PRICE	AGE	REMD	CND	UNADJ VAL	PHYS	PHYS VAL	FUNC	TRUE VAL
DWELLING	1	SK	1,716	C		1974		A	316,030	35	205,420		205,400
1 Gar - Frame	10	20x30	600	D	18.96	1974		A	11,380	80	2,280		2,300
2 Pole Bldg	14	24x48	1,152	C	12.51	1989		A	14,410	57	6,200		6,200
3 Shed	6	12x16	192	C	9.90	1974		A	1,900	80	380		400
4													
5													
6													
7													
8													
9													
10													
11													

04-002300.0000	TOTAL	214,300
----------------	--------------	---------

COMMENTS

Dwelling has an Economic Factor of 100% (Rollback Basis=\$228,600)